



# APPLICATION DATA

**AD353-104**

Issue: 1

March 1997

## PAC 353™ COMBUSTION MANAGEMENT SOLUTIONS O<sub>2</sub> TRIM CONTROL

### BENEFITS

◇ Maximizes boiler operation by improving control of the air/fuel ratio.

### INTRODUCTION

This paper is one in a series that discusses Moore Products Co.'s Combustion Management Solutions. This installment discusses O<sub>2</sub> Trim Control.

### BACKGROUND

Oxygen trim control, also known as flue gas analysis trimming, can be applied to all types of basic boiler control systems. Oxygen trim control can be used to more accurately control the air/fuel ratio. Automatic air/fuel ratio adjustment is generally based on the percentage of excess oxygen (O<sub>2</sub>) in the flue gas. If air and fuel are mixed in chemically correct (stoichiometric) proportions, the theoretical products of combustion are carbon dioxide and water vapor. Under ideal conditions, all of the oxygen supplied in the air is consumed by the combustion process. Due to incomplete mixing, however, it is always necessary to provide more air than the theoretically correct mixture. This results in a small percentage of excess O<sub>2</sub> in the flue gas. A flue gas oxygen analyzer supplies feedback on the combustion process and is the basis for trimming the air/fuel ratio to maintain optimum combustion.

### MEASUREMENT

Special analyzers are used to perform a flue gas analysis. These analyzers measure the amount of excess oxygen being exhausted to atmosphere.

### CONTROL

The adjacent figure shows one method of trimming the air/fuel ratio based on O<sub>2</sub> control. The optimum percentage of O<sub>2</sub> in the flue gas depends on the type of fuel and varies with load. Therefore, the O<sub>2</sub> setpoint is characterized as a function of steam flow, which provides an index of the boiler load.

The following table lists typical instruments for an O<sub>2</sub> trim control system. This list is a guide. Consult your Moore representative for more information.

#### Instrumentation List

ITEM	MODEL
Controller	353A2FNNNNNNA4

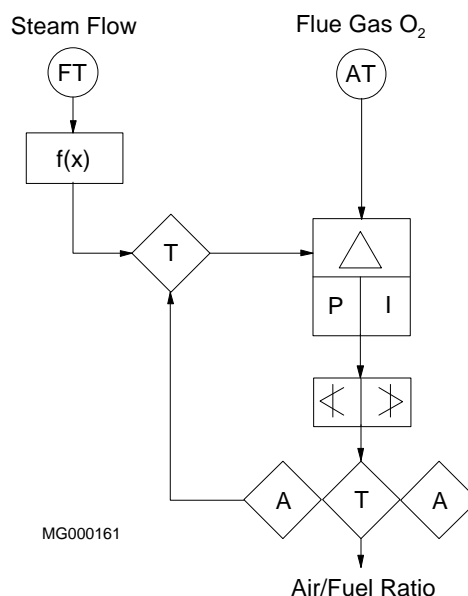

*Moore Products Co. assumes no liability for errors or omissions in this document or for the application and use of information included in this document. The information herein is subject to change without notice.*

*Moore Products Co. is not responsible for changes to product functionality after the publication of this document. Customers are urged to consult with a Moore Products Co. sales representative to confirm the applicability of the information in this document to the product they purchased.*

