



3170 Wasson Road • Cincinnati, OH 45209 USA
Phone 513-533-5600 • Fax 513-871-0105
info@richardsind.com • www.jordanvalve.com

I & M Mark 60 (1/4" - 2")

Installation & Maintenance Instructions for Mark 60 Sliding Gate Pressure Regulators

Warning: Jordan Valve Pressure Regulators must only be used, installed and repaired in accordance with these Installation & Maintenance Instructions. Observe all applicable public and company codes and regulations. In the event of leakage or other malfunction, call a qualified service person; continued operation may cause system failure or a general hazard. Before servicing any valve, disconnect, shut off, or bypass all pressurized fluid. Before disassembling a valve, be sure to release all spring tension.

Please read these instructions carefully!

Your Jordan Valve product will provide you with long, trouble-free service if it is correctly installed and maintained. Spending a few minutes now reading these instructions can save hours of trouble and downtime later. When making repairs, use only genuine Jordan Valve parts, available for immediate shipment from the factory.

Ideal Installation

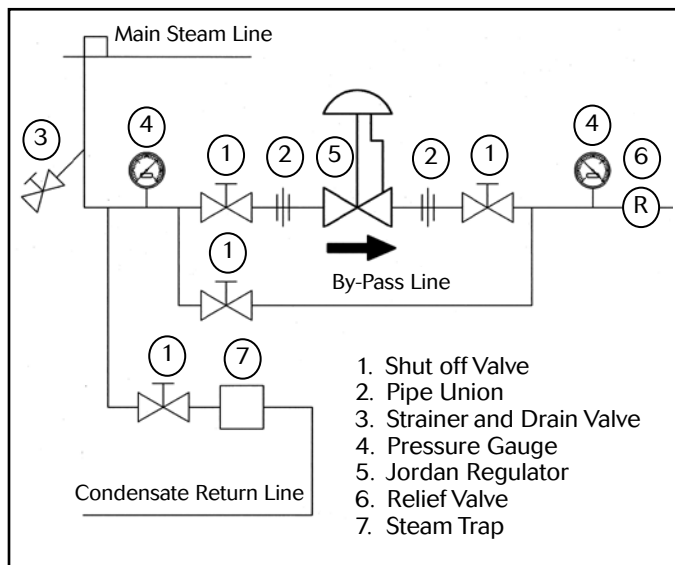

1. To protect the valve from grit, scale, thread chips and other foreign matter, ALL pipelines and piping components should be blown out and thoroughly cleaned before the installation process begins.
2. Shutoff valves, pressure gauges and by-pass piping should be installed as indicated in the Ideal Installation Schematic to provide easier adjustment, operation, and testing.
3. A line strainer should be installed on the inlet side of the valve to protect it from grit, scale and other foreign matter. A 0.033 perforated screen is usually suitable for this purpose. Line strainers are available from Jordan Valve.
4. For best control, 3' 0" straight sections of pipe should be installed on either side of the valve.

5. In preparing threaded pipe connections, care should be exercised to prevent pipe-sealing compound from getting into the pipelines. Pipe-sealing compound should be used sparingly, leaving the two end threads clean. Jordan uses, and recommends, thread sealer Teflon ribbon.
6. The flow arrow on the valve body must be pointed in the direction of flow. Ideally, the valve should be installed in the highest horizontal line of piping to provide drainage for inlet and outlet piping, to prevent water hammer, and to obtain faster response.
7. If possible, install a relief valve downstream from the valve. Set at 15 psi above the control point of the valve.
8. In hot vapor lines, upstream and downstream piping near the valve should be insulated to minimize condensation.
9. In gas service, if the control pressure (downstream) is 25% of the inlet pressure or less, expand the outlet piping at least one pipe size. A standard tapered expander connected to the outlet of the valve is recommended.
10. Where surges are severe, a piping accumulator is recommended.
11. On steam control applications, install a steam trap with sufficient capacity to drain the coil or condenser. Be sure to have a good fall to the trap, and no backpressure. Best control is maintained if the coil or condenser is kept dry.

Start-Up

1. Fully open the outlet shut-off valve.
2. Slowly open the inlet shut-off valve.
3. Slowly open and close the outlet shut-off valve several times. This fully strokes the valve to insure satisfactory operation.
4. With the outlet shut-off valve open, slowly screw down the adjusting screw until the desired pressure is shown on the outlet pressure gauge.
5. To change the controlled pressure, turn the adjusting screw clockwise to increase pressure, counter-clockwise to decrease pressure.
6. Body and cap bolts should be retightened per torque procedures after valve reaches operating temperature.

Maintenance

Caution: Ensure that the valve is de-pressurized before loosening any fittings or joints. The following steps are recommended before performing any maintenance on the valve:

1. Close the inlet shut-off valve.
2. Allow pressure to bleed off through the downstream piping. Do not attempt to reverse the flow through the valve by bleeding pressure from the upstream side of the valve.
3. When the pressure gauges indicate that all pressure has been removed from the system, close the outlet shut-off valve. The valve may be removed from the line and serviced.

Note: Refer to the drawing at the end of this document for description and proper orientation of parts.

Valve Seats

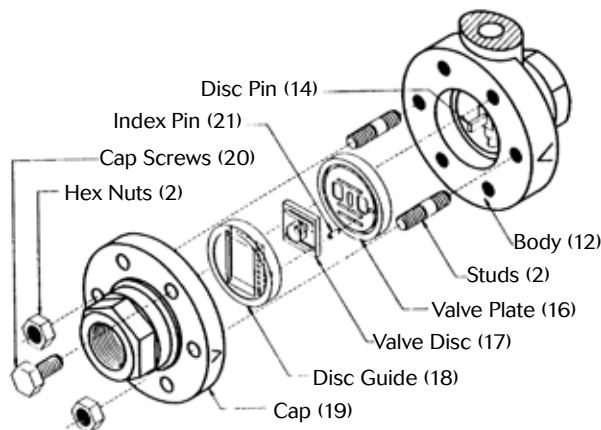

A. DISASSEMBLY

Jordan Valve Sliding Gate Seats are lapped to light band flatness. Maintaining such tolerances is of paramount importance for your assurance of excellent control and tight shutoff. DO NOT use metallic objects in removing the seats. Care in handling is important.

1. Following the Maintenance procedures to remove the valve from line.
2. Note scribes "<" on the side of the body (12) and cap (19). Secure the body flats in a vise. Remove the cap bolts (20) and two nuts from the studs. Lift the cap straight up.
3. Remove the disc guide (18) by lifting straight up – protect the lapped surfaces on both sides of the disc guide. Before removing, check the disc (17) for a stamped arrow. This arrow points to the "<"

on the valve body. (NOTE: discs that can be rotated 180° without affecting the stroke may not have arrows.) Lift straight up on the disc (17). Place the disc on the bench lapped surface facing up. Remove the index pin (21).

It is imperative that the disc pin (14) assembly is not rotated when disassembling, cleaning or reassembling, since this affects the stroke adjustment of the valve.

4. Invert the body and lightly tap on the exterior to remove the plate (16). Let the plate drop out into your hand, and place it on the bench with the lapped surface facing up. If the plate sticks lightly tap on the back of the plate with a soft blunt object; push the plate (16) out evenly.
5. Clean all the parts, body and cap with solvent. Inspect body and cap bores for damage. If the parts are scarred, do not attempt to re-lap them, but return them to the factory for repair or replacement.
6. The vertical sections of the disc guide (18) serve as guides for the disc (17) while stroking. A 0.005 feeler gauge should be used to check for clearance between this surface and the side of the disc. If the clearance is less, clean the guide surfaces in the disc guide with a fine file.

B. REASSEMBLY

1. Lightly coat the outer ring on the unlapped side or the plate (16) with anti-seize compound.
2. Place the plate (16) in the body, lapped surface facing the cap. The index-pin hole should be on the same side of the body as the "<" on the body. Align the disc pin (14) so that it is centered in the body bore and that it protrudes through the center slot in the plate (16). Place the disc (17) on the plate (16), engaging the disc pin (14). The arrow on the disc (17) should point to the index-pin hole. Insert the index-pin (21) in the hole.
3. Coat the outer ring on the side of the disc guide without the index pin hole, with a light coating of anti-seize compound.
4. Place the disc guide onto the plate (16), engaging the index pin (19). Rotate the assembly slightly until the slot openings in the disc are parallel to the openings in the plate, and perpendicular to the stem. Stroking the valve will aid in this alignment.
5. Align the ">" on the cap (19) with the "<" on the body (12), and place the cap over the two studs in the body.
6. Install the nuts and cap bolts (20). Tighten uniformly. See page four for torque requirements and tightening procedures.

Diaphragm Replacement

A. DISASSEMBLY

1. Remove all of the compression from the spring (7) by rotating the adjusting screw (1) counterclockwise until it moves freely. *(Failure to remove the compression from the spring could result in personal injury or damage to the valve.)*
2. Remove the spring housing bolts (5) and spring housing (4). Remove the spring (7) and spring seat (6).
3. Remove the diaphragm assembly by rotating counterclockwise. The diaphragm assembly consists of the upper diaphragm plate (8), diaphragm (9) and lower diaphragm plate (10).
4. If the diaphragm must be replaced, secure the upper diaphragm plate (8) in a vise. A 3/16" face spanner wrench should be used to remove the lower diaphragm plate (10) from the assembly.
5. Remove the diaphragm (9) and reassemble in reverse order.

B. REASSEMBLY AND STROKE ADJUSTMENT

1. Note that the valve stroke adjustment is determined by how far the diaphragm assembly is screwed into the stem. Screw the diaphragm assembly onto the stem until the disc pin is centered in the valve body.
2. Push the diaphragm assembly down against the valve body and check the orifice alignment of the disc (17) and the plate (16). The orifices should be fully open and in perfect alignment.
3. If the orifices are not in perfect alignment, rotate the diaphragm assembly counterclockwise to lower the disc, and clockwise to raise the disc.
4. The total stroke of the Mark 60 is equal to the orifice width plus 1/32" overlap. Consequently, perfect adjustment is required for proper operation.
5. When seats are in perfect alignment, proceed with the assembly of the spring housing.
6. Place the spring (7) on the upper diaphragm plate (8) and the spring seat (6) on the spring.
7. If the diaphragm is metal, be sure that the diaphragm is aligned in the body recess. This recess also aligns the spring housing (4). Be sure that the bleed hole is facing downstream.
8. If the diaphragm is elastomer, make sure that after the seats are in perfect alignment that the bolt holes are in alignment. If an adjustment needs to be made to align the bolt hole, make the adjustment by turning the diaphragm assembly clockwise.
9. Install and tighten the spring housing bolts (5) per the torque instructions on the back page.

Stroke Adjustment

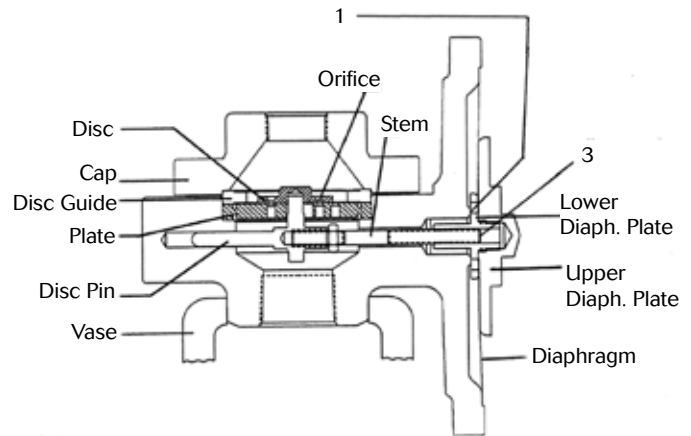

1. The stroke adjustment is made with the spring housing and adjusting spring removed from the valve.
2. The valve orifices should be open and in perfect alignment when the diaphragm assembly is pressed against the valve body as illustrated.
3. The valve stroke adjustment is determined by how far the stem is screwed into the diaphragm plate. Rotate the diaphragm assembly to raise or lower the valve disc. Unthread the diaphragm assembly partially to lower the disc or thread the stem deeper into the assembly to raise the disc.

If Stroke is Too Short:

To correct, turn the diaphragm assembly toward you (unthreading it from the stem) bringing the disc orifices into alignment with the plate orifices.

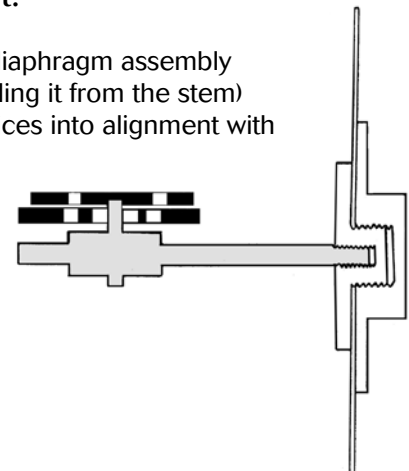

If Stroke is Too Long:

To correct, turn the diaphragm assembly away from you (threading it farther onto the stem) bringing the disc orifices into alignment with the plate orifices.

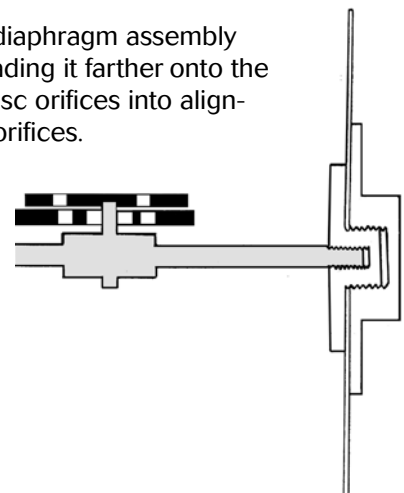

Disc Pin

1. Remove the disc and the plate, following the procedure outlined under VALVE SEATS.
2. Remove the diaphragm as outlined under DIAPHRAGM REPLACEMENT.
3. Holding the disc pin assembly with an open-end wrench, loosen the locknut (13). The stem (11) can now be unscrewed from the disc pin (14) and the locknut removed from the stem.
4. Remove the stem (11) upward through the diaphragm area and the disc pin (14) through the body orifice.
5. Check the condition and clean all parts. Clean the lower guide hole in the valve body and replace defective parts.
6. Reassemble in reverse order and follow the procedures outlined under DIAPHRAGM REPLACEMENT and VALVE SEATS for proper adjustment. When reassembling, thread the stem (11) fully into the disc pin (14) and then tighten the locknut (13).

Troubleshooting

If You Experience Erratic Control:

- Oversizing causes cycling and hunting, and reduces the rangeability of the valve. Make certain that your sizing is correct.
- Steam traps downstream may require maintenance.
- Safety valve may be defective and need repair.
- There may be excessive foreign matter on the seats, and seats should be removed and cleaned.
- Valve stroke may need readjustment.
- Valve disc may not be moving freely. Check disc guide clearance and correct if needed.

If Valve Will Not Operate:

- Diaphragm may be ruptured and require replacement.
- Adjusting spring may be broken and require replacement.
- Spring may be set improperly and require resetting.

Ordering Spare Parts

Use only genuine Jordan Valve parts to keep your valve in good working order. So that we can supply the parts, which were designed for your valve, we must know exactly which product you are using. The only guarantee to getting the correct replacement parts is to provide your Jordan Representative with the valve serial number. This number is located on the valve identification tag. If the serial number is not available, the parts needed for your valve might be determined using the following information: Model Number, Valve Body Size, Seat Material and Cv Rating, Spring Range and Set Point, Trim Material, Part Name - Number and Quantity.

NOTE: Any parts ordered without a valve serial number that are found to be incorrect are subject to up to a minimum 25% restock charge when returned.

Torque Values

Bolt Pattern / Torquing Sequence

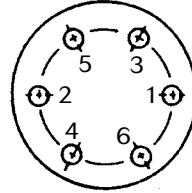

6 bolts
(or multiples)

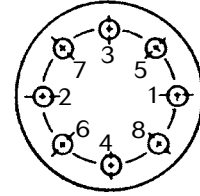

8 bolts
(or multiples)

Torque for Bolts Connecting Cap to Body (in. - lbs.)

Valve Size	Valve Body Material	
	Bronze	Ductile Iron, Carbon Steel, or Stainless Steel
1/2" through 2"	140	200

Torque for Spring Housing Screws

Valve Size	Torque (in. - lbs.)
1/2" through 2"	200

Illustration and Parts List

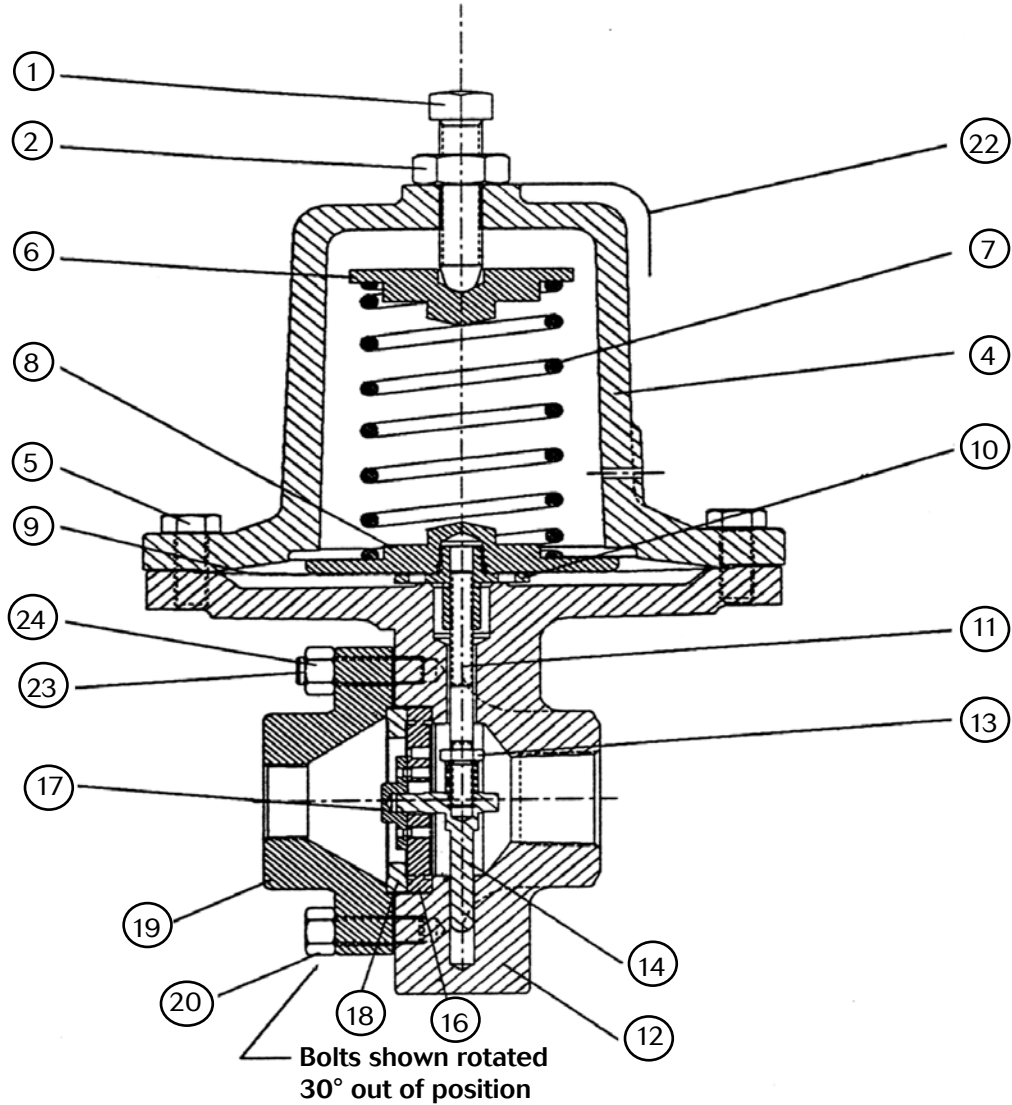

Item	Description	Item	Description
1	Adjusting Screw	*13	Stem Locknut
2	Locknut (Adjusting Screw)	*14	Disc Pin
4	Spring Housing	*16	Plate
5	Bolt (Spring Housing)	*17	Disc
6	Spring Seat	*18	Disc Guide
7	Spring	19	Cap
8	Upper Diaphragm Plate	20	Bolt (Body)
*9	Diaphragm	21	Index Pin (not shown)
10	Lower Diaphragm Plate	22	Name Plate
*11	Stem	23	Stud (Body)
12	Body	24	Nut (Body Stud)
*	Recommended Spare Parts		