

IRIS



WATCHDOG III FLARE STACK MONITOR IRIS MODELS P222 and S256B UV OPERATION MANUAL



WORLD LEADER IN FLAME MONITORING

Table of Contents

INTRODUCTION □	3
POWER REQUIREMENTS.....	3
SIGNAL PROCESSOR WIRING	3
FIGURE 1: P222 CONNECTIONS	4
FIGURE 2: VIEWING HEAD CONNECTOR WIRING	5
FIGURE 3: CONNECTOR WIRING.....	6
SELF-CHECKING FUNCTION	8
FRONT PANEL LED INDICATIONS	8
PUSH BUTTON FUNCTIONS.....	8
CALIBRATING THE P222	9
MODULE COMMUNICATIONS.....	10
COMMUNICATION WITH HUMAN-INTERFACE HOST COMPUTER	11
RS-422 CONVERSION	11
CONTACT INFORMATION	11
FIGURE 5: VIEWING HEAD YOKE AND MOUNT DIMENSIONS.....	12
FIGURE 4: S256B VIEWING HEAD DIMENSIONS.....	12
FIGURE 7: P222 SIDE DIMENSIONS	13
FIGURE 6: P222 FRONT DIMENSIONS	13

INTRODUCTION

The Watchdog III Flare Stack Pilot Monitoring System consists of two components, the Model S256B viewing head, and the Model P222 signal processor. The Watchdog III Flare Stack Pilot Monitor electro-optically detects the presence or absence of a flame at the flare tip.

Continuous monitoring of the flare pilot is critical to ensure no unburned toxic or waste gases are released into the atmosphere. The Watchdog III's ultraviolet sensor dependably and reliably monitors the amount of ultraviolet energy being emitted by the flame.

When ultraviolet (UV) energy from the flame is detected, the Watchdog III indicates that the pilot is present. When no UV energy is received, one of the two independent relays in the signal processor can be adjusted to de-energize within one minute, providing a preliminary "flame loss" alarm. The second relay also de-energizes but only after a longer adjustable time-delay. Consequently, it provides a final "flame out" alarm.

The Watchdog III is ground-mounted up to 1000 feet from the stack tip. This allows the system to be installed and made operational without interrupting the operation of the flare stack or shutting down the plant. This also allows maintenance personnel easy access to the instrument should servicing be required.

Other features include security and field upgradeable flash programming.

POWER REQUIREMENTS

The P222 can be powered from an AC Line Voltage between 85 to 264VAC at 47 to 440 Hz., or from an external 24VDC power supply. A 30W power supply, such as the IRISPS030, is sufficient to power both the signal processor and viewing head.

The viewing head is powered by the P222 signal processor via a 0.25A self-resetting fuse. The power to the signal processor itself is via a 0.75A self-resetting fuse. These self-resetting fuses are re-set when power to the signal processor is removed.

SIGNAL PROCESSOR WIRING

The P222 signal processor should be mounted in a suitable weatherproof enclosure that is approved for

the conditions for the area.

Refer to Figure 1 on the following page, and proceed to wire the signal processor as follows:

AC Powered:

Connect AC Line power to terminal AC1

Connect AC Neutral to terminal AC2

Connect Ground to terminal GND

DC Powered:

Connect +24VDC power to +24V IN

Connect -24VDC power to GND

Relay R1 (Early Indication)

Relay R1 will energize when flame is detected, and de-energize when flame has not been detected for R1 Time Delay seconds. When energized, the R1 RELAY ON Led on the front panel will be illuminated. Typically, this relay would be used to trigger an ignition system to attempt to re-ignite the flame. It could also serve to trigger an alarm as a warning of loss of flame. So two sets of Form C contacts are provided (DPDT).

Connections to this relay are made on the top right terminal connectors.

R1A COM and R1B COM are the common terminals, with R1A ON and R1B ON being closed for Flame On, and R1A OFF and R1B OFF being closed for Flame Off.

Relay R2 (Delayed Indication)

Relay R2 is a time delayed Flame Off alarm relay. The time delay serves to provide a *Definite* FLAME OUT indication. When the pilot flame is detected, the relay energizes immediately and provides a FLAME ON indication. The R2 RELAY ON LED on the front panel will be illuminated. When a flame is no longer detected, this relay has a delayed response and only de-energizes after its (adjustable) delayed amount of time. (The time delay for Relay R2 must be longer than the delay for Relay R1)

Connections to this relay are made to the top center terminal connector. One set of Form C

contacts are provided (SPDT).

R2 COM is the common terminal, with R2 ON being closed for Flame On (Delayed), and R2 OFF being closed for Flame Off (Delayed).

Viewing head connections

Connections to the viewing head are made to the connector on the bottom right.

For wiring, see the diagram in Figure 2.

Ensure that the viewing head signal wire and the signal ground (braided shield in the four conductor cable) are both connected, since this ground connection is the only return path for the signal and self checking circuit.

Verify that the terminating resistor is connected between SC and SIG GND.

Remote Meter

The pair of terminals designated RMT METER (to the left of the CHAN SEL terminals) is for the *remote meter connection*. This output is a current-driven signal that ranges from 0 to 20mA for remote meters, and can be switched to a range of 4 to 20mA for DCS (*distributed control system*) applications (refer to section **Gain Set button (adjusting 4 to 20 mA output)**).

Connect the terminal marked “positive” to the positive meter terminal. This current signal can be used with a volt meter by feeding the signal to a resistor connected to the ground. The voltage developed across the resistor will follow Ohm’s law $V = IR$. (for accurate

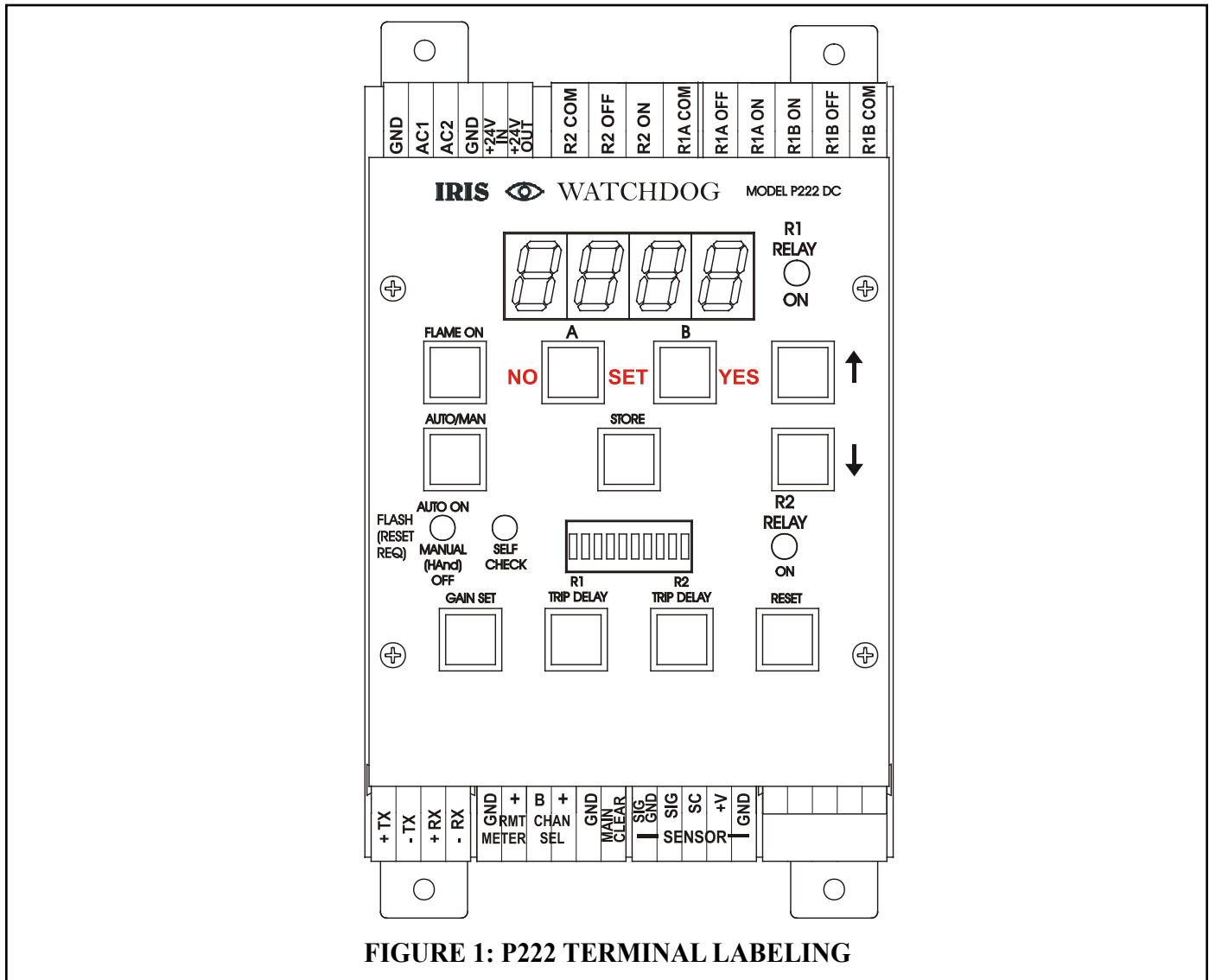

FIGURE 1: P222 TERMINAL LABELING

reading a maximum resistance of 360 ohms is required)

For example: a 3-volt meter can be used with a resistor of $3/.02 = 150$ ohms, which will result in a full-scale reading of 3 volts for a 20mA output.

The four terminals labeled +TX, -TX, +RX, and -RX (to the left of RMT METER terminals) are used for the serial communication link. Serial communication is achieved by using Modbus RTU binary code transmission at 4800, 9600, 19200 or 38400 baud through the RS232 com ports on the host computer with odd, even or no parity. (default settings are 9600 baud with no parity.)

The P222 uses RS-422 data transmission over two, twisted pairs that are differentially transmitted and received, allowing long wire runs to be used through noisy environments. An RS-232 to RS-422 converter must be used to communicate with the P222, and the connections are made to the terminals marked +TX, -TX, +RX and -RX. The transmitting, twisted pair goes to the TX terminals, and the receiving, twisted pair goes to the RX terminals.

Note: the terms “transmit” and “receive” used here with respect to the P222 will be *reversed* with respect to the RS-232 connection on the host computer.

Channel Select

A second set of configuration parameters can be stored and used in circumstances where flame characteristics and/or delay times changes at a known time.

To set channel B configuration parameters press hand hold the “B” button until it begins to flash quickly (the P222 is now in B channel adjust mode and all configurations for viewing head gain , time settings and flame off level can now be adjusted.

NOTE: Whenever Channel A or Channel B parameters are being adjusted the appropriate channel light will flash quickly.

To Use Channel B configuration, switch a voltage (12 to 24 VDC) to the CHAN SEL pins on the lower terminal strip (There is also a register available using Modbus to switch over if using computer control)

Manual Clear

In manual mode, (HAnd), the Signal processor will not automatically respond (energize the relays) after a loss of flame until manually acknowledged (cleared)

Manual mode is indicated by the Auto/Manual (yellow LED) being off. In this state the processor will respond to flame detection.

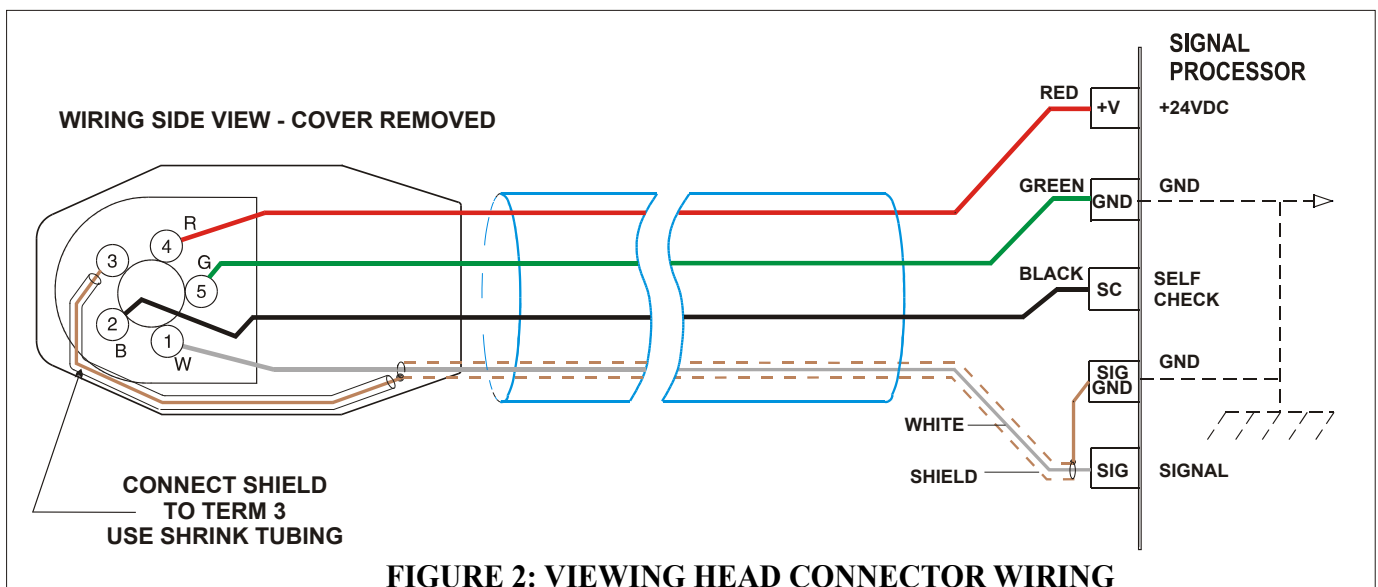

IRIS CABLE

3 CONDUCTORS PLUS 1 COAX
 3 CONDUCTORS: 16 AWG 19 STRAND INSULATED WITH
 CROSSED-LINKED-POLYETHYLENE .017 THK
 COLORS: BLACK-RED-GREEN
 1 COAX: 16 AWG 19 STRAND INSULATED WITH
 CROSSED-LINKED-POLYETHYLENE .017 THK COLOR WHITE
 36 AWG BRAIDED SHIELD 90% COVERAGE
 WITH .012 THK JACKET COLOR BLACK
 CABLED: POLYPROPYLENE FILLERS FOR ROUNDNESS
 JACKET: CROSSED-LINKED-POLYETHYLENE .036 THK
 COLOR LIGHT BLUE

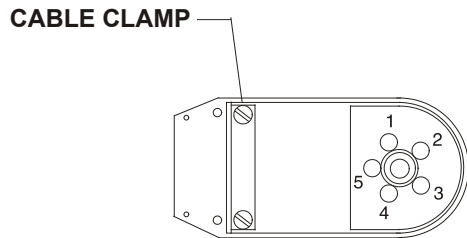
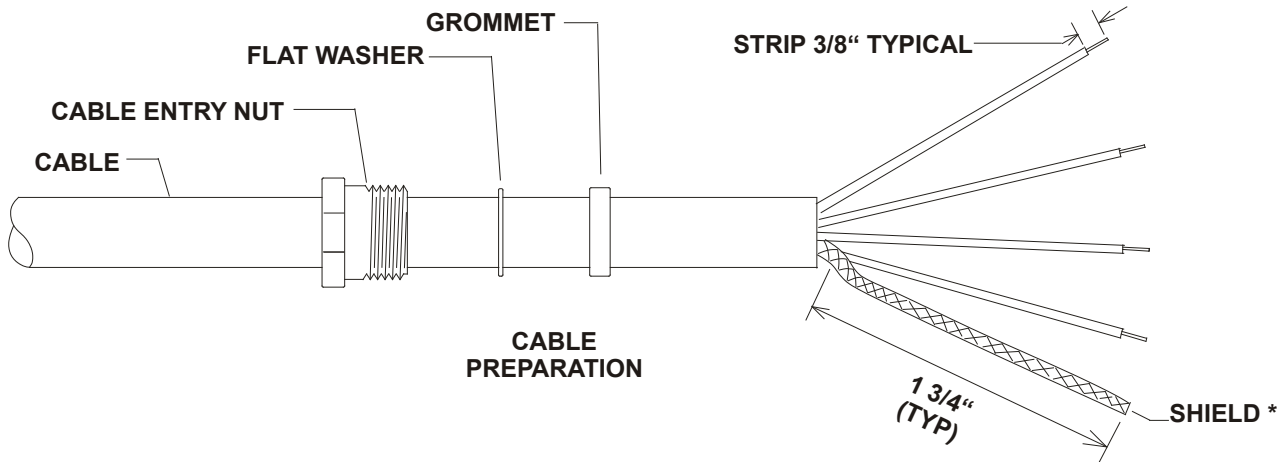

INSULATE SHIELD WITH SHRINK TUBING LEAVING 3/8" STICKING OUT

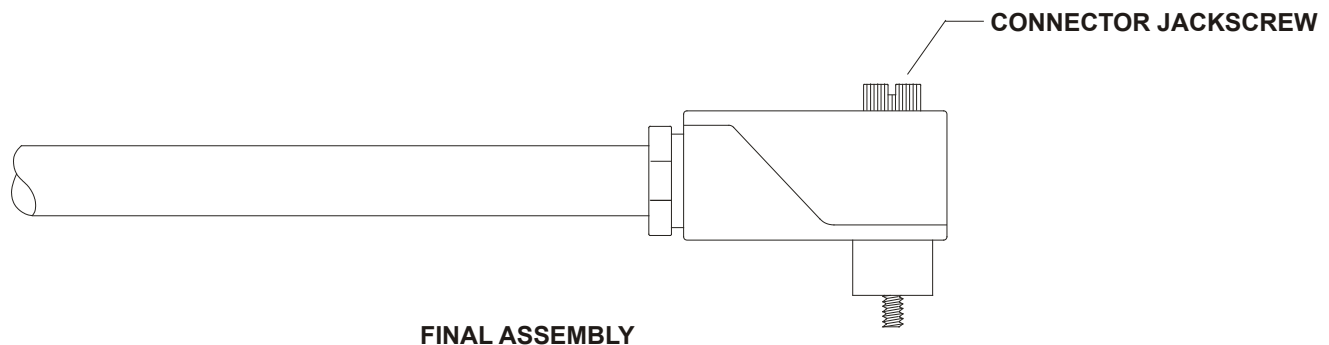

*** CABLE IS SHOWN WITH SHIELD ALREADY REMOVED FROM WHITE WIRE**

FIGURE 3: CONNECTOR WIRING

Once a flame is detected the unit will energize the relays and monitor the flame. If the flame signal is absent for a period equal to the longest delay (relays de-energized) the processor will enter the Manual Mode Tripped state (yellow led flashing). In this mode the relays will not be energized if the flame is detected unless the manual mode is cleared by either a remote switch on the MAN CLEAR Terminal to Ground, or by pressing the RESET button. Note that pressing the RESET button in Manual mode will toggle between Tripped and back to ready states (indicated by the yellow LED flashing or off).

Remember: If the yellow LED is flashing, the relays will **NOT** be energized even if flame is detected.

WIRING THE VIEWING HEAD

Wiring of the viewing head is made to the terminals located on the lower right side of the P222 signal processor.

These terminals are described as follows:

TERMINAL	DESCRIPTION
GND	Power Ground
+V	+24VDC Power to Viewing Head
SC	Shutter Drive Signal to Viewing Head
SIG	Flame Signal from Viewing Head
SIG GND	Signal Ground

Figure 2 shows a four-conductor cable connected to the viewing head. Note that the flame signal wire going to terminal SIG is shielded, and the shield is terminated at **both** ends of the cable to SIG GND.

A *source impedance resistor* is required on the P222 signal processor when attached to the P256 viewing head. This resistor should be 330 ohms (factory installed) for viewing head cable runs up to 500 feet, and it should be 150 ohms for cable runs of 500 feet to 1000 feet. The resistor should be installed across the SC and SIG GND terminals on the signal processor. A 1/4 watt resistor is suitable.

It should be noted that the flame signal wire is shielded, and that the shield is terminated at both ends. The shield must be a braided type for this ap-

plication in order to maintain an electrical path. For this reason, a foil type shield should not be used. This signal ground shield is also the self-checking circuit return path. It is recommended that IRIS C328 cable be used for all applications.

Connection of the IRIS type C328 cable to the viewing head plug is in **Figure 3, Connector Wiring**, and should be done as follows:

Remove the cable entry nut from the plug housing. Remove the rubber grommet and flat sealing washer. With a pair of long-nosed pliers remove the center ring only of the rubber grommet.

1. Strip 2 inches of the cable outer cover from the cable removing any cellophane wrap or filler material. Strip the insulation from the shielded wire (if insulated over shield) a full 2 inches to expose the shield.
2. Slide the shield back until a bulge develops close to where the wire exits the cable outer covering.
3. Carefully spread a few strands of the shield at the bulge (making sure not to break any strands) to create an opening and pull the wire out of shield through opening.
4. Carefully return shield to original shape and length by pulling gently, then cover the shield with heat shrink tubing to insulate it.
5. Slide the nut (with threads toward the cable end), the washer and the grommet approximately six inches onto the cable.
6. Slip the cable through the bottom opening of the connector making sure that the cable outer jacket is secure under the cable clamp and tighten the two screws on the cable clamp.
7. Reassemble the grommet, flat washer, and cable entry nut and tighten.
8. Strip each wire 3/8" as shown in the assembly drawing figure 2 on the following page.
9. Proceed to wire the connector as follows: (Refer to the wiring diagram figure 1 for terminal locations.)

Connect the viewing head signal wire (the shielded wire) WHT to terminal No. 1 by inserting into opening and then tightening the retaining screw.

Connect the self-checking signal wire BLK to terminal No. 2.

Connect the signal ground shield from WHT wire with shrink tubing to terminal No. 3.

Connect the + 24VDC power wire RED to terminal No. 4.

Connect the power ground wire GRN to terminal No. 5.

Assemble the back of the plug and insert the jackscrew through plug assembly.

The cable at the signal processor end should be prepared in a similar way to the plug end, particularly the shield from the WHT wire. Follow the wiring connections as shown in the wiring diagram figure 1, making sure that the shield does not touch the other adjacent terminals.

SELF-CHECKING FUNCTION

When energized, the self checking function indicates that both the P222 signal processor and the viewing head are functioning properly. The software in the P222 signal processor will cause the SELF CHECK LED on the front panel to flash at the rate of once per second, indicating normal operation.

Any component failure will cause a lockout condition that will de-energize the flame relays. The SELF CHECK light on the P222 will indicate this condition with a steady on or off illumination requiring a reset to return to normal flame monitoring mode.

A reset can be achieved only if the lockout condition has been corrected, and can be performed from the front panel (by pressing the RESET button), or remotely through the serial communication.

FRONT PANEL LED INDICATIONS

The following describes the functions of the Led indicators on the front panel of the P222 signal processor:

1. RELAY R1 ON LED (RED)

Only Illuminated if the Early relay R1 is energized

2. RELAY R2 ON LED (RED)

This LED will be Illuminated if the delayed relay R2 is energized

3. AUTO ON MANUAL (HAnd) OFF LED (ORANGE)

- Not Illuminated (OFF) indicates “Manual” (HAnd) mode
- Already acknowledged (relays will energize at first flame detection) and
- Operational (at least one relay is energized).
- Illuminated steady (On) indicates “Auto” mode. (default)
- Flashing indicates “Manual Mode Tripped” (requires Acknowledgment) by pushing RESET button

4. SELF CHECK LED (GREEN)

- Heart beat (one pulse a second) indicates system normal.
- Illuminated steady (ON) indicates LOCK-OUT (viewing head error).
- Not Illuminated (OFF) indicates No power or other fault (not normal).

PUSH BUTTON FUNCTIONS

1. FLAME ON

- Used for setting the single flame trip point

2. AUTO/MAN

- Used to change between Automatic (Auto) and Manual (HAnd) Acknowledge mode.
- One push does the change.
- LED is toggled and the new mode is spelled out (Auto or HAnd)
- If no flame signal and Manual mode is selected then (relays will energize on first flame detection)
- This mode can be canceled with the reset button (Manual LED will flash)

3. R1 TRIP DELAY (formerly FFRT)

- Used to set the first trip time delay 1 to 60 seconds
- Cannot be greater than Main trip relay

delay (below)

- Displays “ __00 “

4. R2 TRIP DELAY

- Used to set the delayed trip time 1 sec to 60 minutes
- Cannot be less than R1 (Warning trip) relay delay (above)
- Displays “ __00” for seconds and “00--” for minutes
- Minutes and seconds (together are not implemented)

5. RESET

- Used to Acknowledge Flame signal (enabling the relays to energize in manual (HAnd) mode).
- Used to toggle between Manual Mode and Manual Acknowledge Waiting.

CALIBRATING THE P222

Setting the R1 Relay Delay

Press the **R1 Trip Delay** button notice the current trip delay is displayed in seconds preceded by two underscores (__ 0 5).

Adjust this to the desired value using the Up and Down arrow buttons and press store. (- - -) will be displayed to indicate that the value has been saved and the value that was saved is re-displayed for verification. The range in seconds is from 1 to 60 or from 1 to the value of R2 relay delay if it is less than 60.

Setting the R2 Relay Delay

Press the **R2 Trip Delay** button. Notice that the current trip delay is displayed in seconds or minutes. If the value is preceded by two underscores (__ 0 5), then the delay is in seconds, else if the value is followed by two dashes (0 5 - -), then the delay is in minutes. Adjust this to the desired value using the UP and DOWN arrow buttons and press STORE. (- - -) will be displayed to indicate that the value has been saved and the value that was saved is re-displayed for verification. The range in seconds is from the value of R1 RELAY delay to 60 minutes.

RELAY R1 time delay cannot be longer than the R2 time delay (they can be equal).

NOTE: If adjusting time delays during the wait period, the new setting will not take effect until after the previous set time has expired (or the flame is detected).

Setting the UV Gain

To scale the UV reading, the gain can be adjusted from 0 (off) to 99.

Press both the **A** and **B** buttons simultaneously “**SET**” (not the Gain Set button). note that the channel being adjusted button is flashing and **AdJ?** is displayed. (to adjust channel “**B**”, press and hold the **B** button until it starts flashing before pressing both **A** and **B**.)

From the **ADJ?** display, press the **YES** button to go to adjust or the **NO** button to go to Default.

In adjust mode note display (Au32). Using the UP and DOWN arrows, adjust the gain to the desired value and press **YES** to store (do not push the STORE button to store the value). (- - -) will be displayed to indicate that the value has been saved and the value that was saved is re-displayed for verification.

In default mode, note display (**dEF?**). Press **YES** to reset all channel settings to default.

The processor will remain in adjust mode until the value is stored with the **YES** button or aborted with the **NO** button.

Gain Set button (adjusting 4 to 20 ma output)

Use the Gain Set button only to adjust the analog output gain (also indicated by the bar graph display). Use the **UP** and **DOWN** buttons to adjust until the correct value is displayed and press **STORE** to save.

Utilizing the bar graph as an indicator to the output is helpful in adjusting this value. The (- - -) will be displayed to indicate that the value has been saved and the value that was saved is re-displayed for verification.

Changing between 0 to 20 and 4 to 20 mA

At power-up, the current setting is displayed (followed by the Firmware version and viewing head detected).

To change to the other mode of analog output:

While holding the UP and DOWN buttons, simultaneously press the FLAME ON, AUTO/MAN and GAIN SET buttons.

While continuing to hold the UP and DOWN buttons, press R1 TRIP DELAY and R2 TRIP DELAY buttons.

While continuing to hold the UP and DOWN buttons, simultaneously press the FLAME ON, AUTO/MAN and GAIN SET buttons. The new setting will be displayed:

S256B Viewing Head Aiming

- A good level of aiming accuracy can be achieved by sighting down the top or bottom of the Viewing Head hood to see the center of the flame.
- For fine adjustments use the flashing rate of the right hand decimal point to maximize the speed of its flashing. If the Right hand decimal is illuminated steady then use the flashing rate of the left hand point decimal point.
- The Right hand decimal point flashes at the extreme highest resolution possible and is only usable if flame counts are low.
- The left hand decimal will flash at a low resolution according to signal strength and Gain
- Display will show a minimum of "1" when any flame signal is received. All other displays is Highest two digits of the Signal processor

Viewing Head Temperature

Press both the RESET and the DOWN Buttons simultaneously to display the internal temperature of the viewing head. Excessively

high temperatures may reduce the life of the viewing head. The P222 will display a high temperature warning by flashing the viewing head temperature if the internal viewing head temperature exceeds recommended limits.

MODULE COMMUNICATIONS

The P222 communicates with any host computer that can be connected to a serial RS422 or RS485 converter running appropriate Modbus protocol software (such as Flame tools for the PC or Palm®). The baud rate is displayed with the module address in the current versions (see **SETTING ADDRESSES**, section). The data transmitted to and from the P222 is over two twisted pairs that are differentially driven and received according to the RS-422 standard. (it can also be configured to communicate over a single shielded twisted pair using the RS-485 standard) The differential mode allows long wire runs in harsh, electrical environments.

Communication Setting (Setting Addresses)

The P222 can communicate in Modbus RTU mode, with the following configuration:

- 4800, 9600, 19200 or 38400 baud (adjustable)
- 8 data bits (fixed)
- none, odd or even parity (adjustable)
- 1 stop bit (fixed)

The factory default of a P222 station number is 0. It is important to change the station number so that there are no duplicate stations.

To change or check the station number of the P222, proceed as follows:

- Press and hold the Reset button for 2 seconds.
- The 4 LED digits will show the baud rate and the station number. The 2 leftmost digits are the baud rate (19, 38, 48 or 96); the 2 rightmost digits are the station number from (0 to 63).
- Press the up/down button to change the station number. Continue up or down to change

the baud rate (i.e. up past 63 for next higher baud or down below 0 for next lower baud rate).

- Press the Store button to save station number.
- Press and hold the Reset button for 2 secs
- The 4 LED digits will show the baud rate and the station number. Simultaneously push the 2 buttons Flame On and Auto/Man. The parity will immediately change to and display the new setting.

MODBUS RTU Functions Supported

- 03 Holding Register Read
- 06 Preset Single Holding Register
- 16 Preset Multiple Holding Register

COMMUNICATION WITH HUMAN-INTERFACE HOST COMPUTER

A number of Modbus drivers for your operating system are available from third party developers. These drivers allow your application programs to communicate with the P222 signal processors directly.

RS-422 CONVERSION

Numerous converters are available to convert to RS-422 or RS-485 from RS-232 , USB, EIA-232-E or TTL serial (Palm® compatible)

CONTACT INFORMATION

Sales and applications support:

IRIS Systems Inc.

7583 Vantage Place

Delta, B.C. V4G 1A5

Canada

Phone: (604) 584-4747

Fax: (604) 581-9790

Manufacturing and Service:

IRIS Systems Inc. (J.B. Systems Inc.)

4944 - 113th Avenue North

Clearwater, Fl 33760

Phone: (727) 545-3900

Fax: (727) 547-9589

REGISTERS MAP			
40001	R/O	Flame Count	
40002	R/O		
	0	Channel	0=Chan A 1= Chan B
	1	Delayed relay R2	Relay R2
	2	Lockout	Processor lockout status 0 = lockout
	3	Panel access	Disabled = 0
	4	Ma out type	1 = 4 to 20
	5	Early relay R1	Relay R1
40003	R/W	Flame on channel A(0 -> 2999)	
40004	R/W	Flame on channel B(0 -> 2999)	
40005	R/O	N/A	Not Implemented
40006	R/O		Not Implemented
40007	R/W	Ma out gain channel A (0 - 99)	
40008	R/W	Ma out gain channel B (0 - 99)	
40009	R/W	Analog IR gain	Not Implemented
40010	R/W	Digital IR gain	Not Implemented
40011	R/W	IR Filter	Not Implemented
40012	R/W	UV tube gain channel A (0 - 99)	
40013	R/W	Analog IR gain	Not Implemented
40014	R/W	Digital IR gain	Not Implemented
40015	R/W	IR Filter	Not Implemented
40016	R/W	UV tube gain channel B (0 - 99)	
40017	R/O	Viewing head A type	
40018	R/O	Viewing head B type	
40019	R/O	Temperature viewing head A	
40020	R/O	Temperature viewing head B	
40021	R/W	Delay time R2 Chan A	1 to 3600
40022	R/W	Delay time R1 Chan A	1 to 60
40023	R/O	Version	
40024	R/O	222	
40034	R/W	Delay time R2 Chan B	1 to 3600
40035	R/W	Delay time R1 Chan B	1 to 60
40062	R/O	Operational time in 2 hr increments	

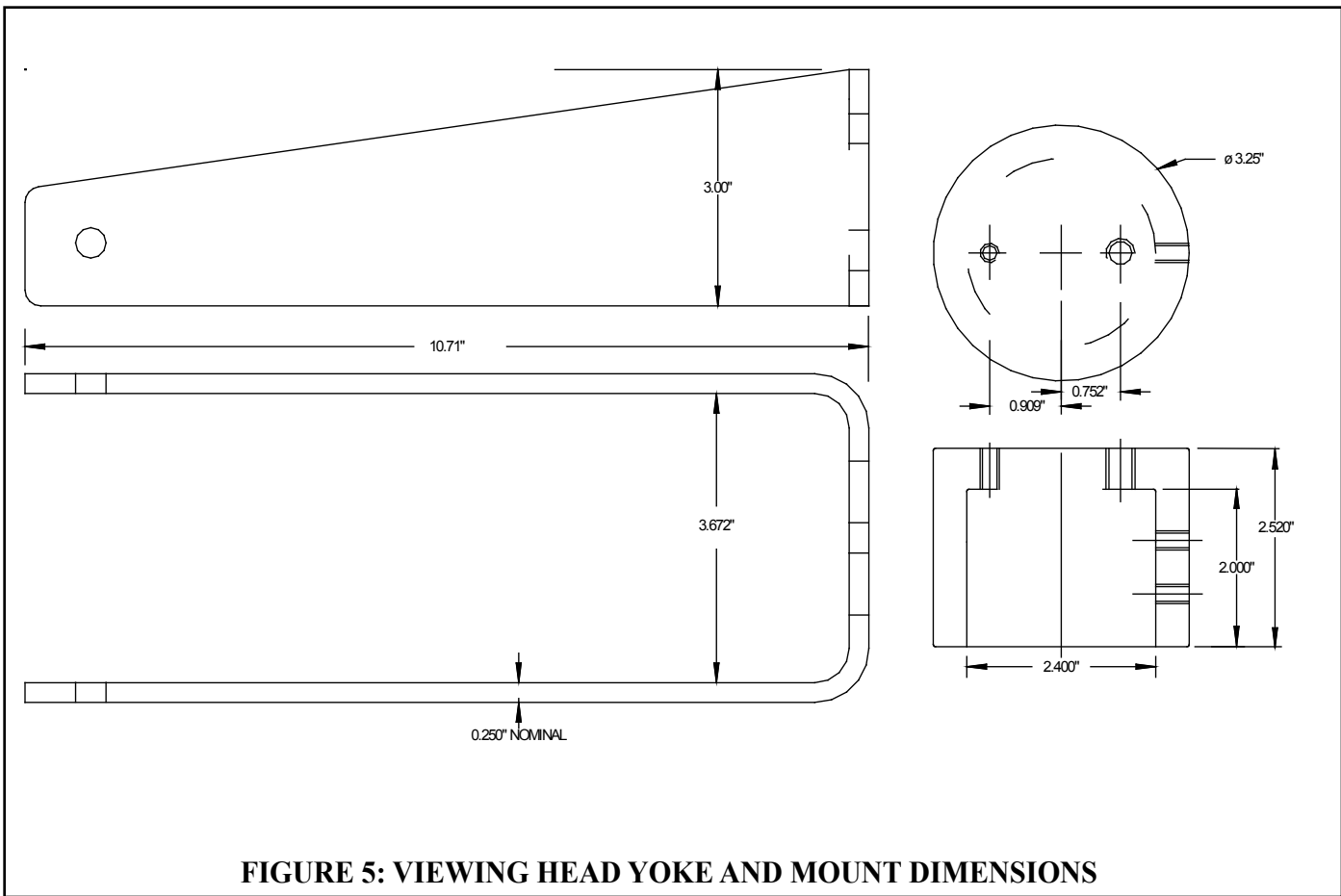
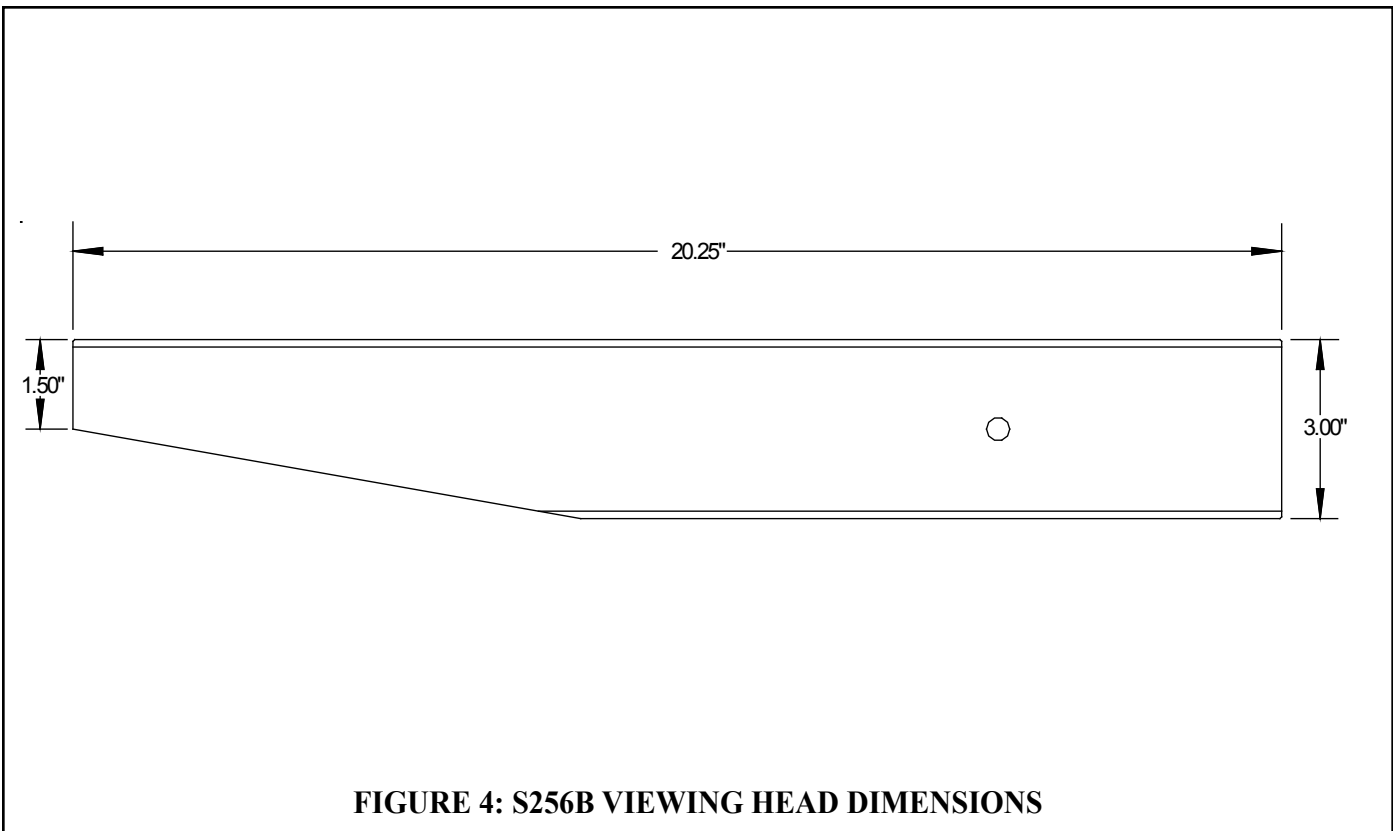

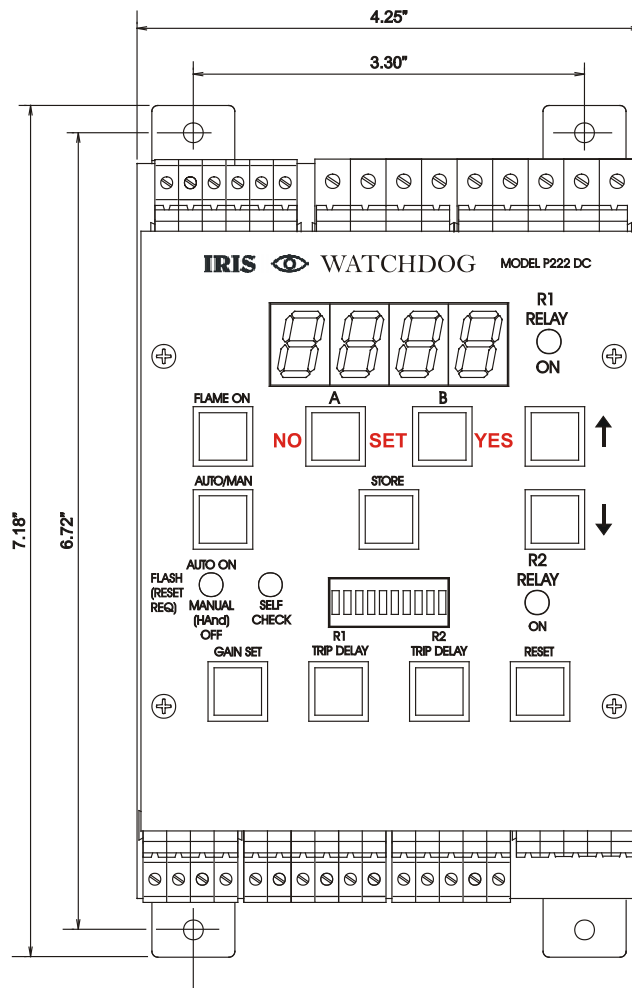

FIGURE 6: P222 FRONT DIMENSIONS

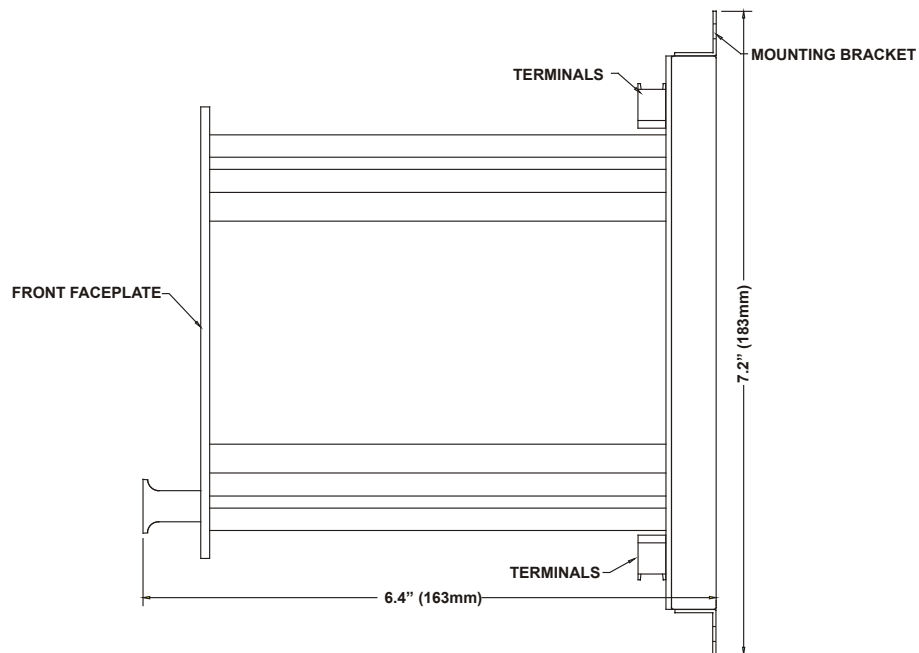

FIGURE 7: P222 SIDE DIMENSIONS

SPECIFICATIONS

ELECTRICAL

AC Power: 85 to 264VAC, 47 to 440 Hz
0.3A RMS Maximum with viewing head connected

DC Power (Backup) 22 to 24VDC, 300 mA with viewing head connected

DC Power (As Main Power) 22 to 26VDC, 300 mA with viewing head connected

ENVIRONMENTAL

Model P222 Signal Processor: Ambient Temperature: 0° C to 60° C (32° F to 140° F)

Model S256B Viewing Head: Ambient Temperature: -40° C to 80° C (-40° F to 176° F)
Viewing head housing: NEMA type 4X

OUTPUTS

Relay R1 (Early Indication): 2 Form C contacts
Contact Ratings: 5A at 30VDC or 250VAC

Relay R2 (Delayed Indication): 1 Form C contact
Contact Ratings: 5A at 30VDC or 250VAC

Analog Flame Signal: 0 to 19.8 mA output for remote meters, or
4 to 19.8 mA output for DCS, etc. (360 ohm max resistance)

Power to Viewing Head: 24 to 26VDC, 150 mA (powered from signal processor)
Fused with self-resetting fuse at 0.25A

INPUTS

Manual Clear: Connect to GND via remote switch to clear

Channel Select: Connect 24VDC to select channel B

SERIAL COMMUNICATION

RS-422/485 (Differential): 4800, 9600, 19200 or 38400 baud (User selected)

VIEWING HEAD

Distance from pilot: Up to 1,000 ft line of sight

Field of view: 40 ft Target diameter at 1,000 ft.

Cable Requirements: 4 Conductor, #16 AWG or #18 AWG,
one wire shielded with braided shield for flame signal.
IRIS C328 or C330 cable recommended.