

PRISMATIC WATER GAGES

SHARP, HIGHLY VISIBLE, ACCURATE WATER LEVEL READINGS

PRECISE, EASY-TO-READ LEVEL GAGES MEET A WIDE VARIETY OF INSTALLATION REQUIREMENTS

Clark-Reliance Prismatic Gages provide a well-defined, distinct image of water levels, eliminating reading errors or distortions possible with less effective gage types. Highly versatile, Prismatic Gages are easily installed in vertical or Tiltview Assemblies. In addition, Clark-Reliance Prismatic Gages offer the flexibility of combining multiple gage sections to achieve coverage of extended viewing areas.

Available in two designs, "C" Types should be specified for pressures to 250 PSI and "S" Types for pressures to 350 PSI.

Typical Prismatic Gage applications include installation on boiler drums, feedwater heaters, deaerators, and other tanks.

Quality Materials Clark-Reliance Prismatic Gages feature quality materials and reliable design. Gage glass is of the highest quality borosilicate glass, tempered for improved toughness against shattering. As an important safety feature, should breakage occur, glass fragments will *interlock* and remain in place.

The unique Clark-Reliance clamping design produces a uniform, firm, strictly compressive load on the glass – adding to gage reliability and prolonged service life.

THE PRISMATIC PRINCIPLE

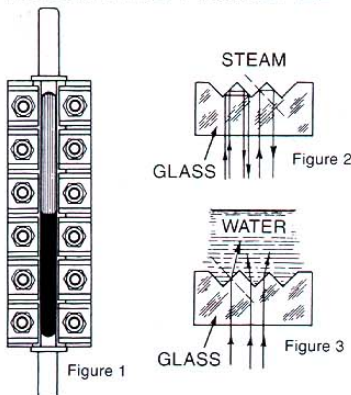

STEAM APPEARS WHITE
 WATER APPEARS BLACK

MULTIPLE SECTIONS ALLOW LONGER LEVEL VIEWING AREAS

Large storage tanks, heater tanks and similar applications call for Prismatic Gage assemblies employing multiple gage sections. Double, triple and quadruple assemblies are readily available, and even longer assemblies can be provided.

In multiple assemblies, the space between gage windows is approximately 1½ inches. This gap is considered insignificant where multiple assemblies are normally installed.

Note the various dimensions and specifications for multiple gage assemblies listed in tables presented elsewhere on these pages.

IN GAGES OF THREE OR MORE SECTIONS, SIDE-MOUNTED REINFORCING BARS CONNECT ALL GAGE BODIES TO ASSURE PROPER ALIGNMENT.

Figure 4

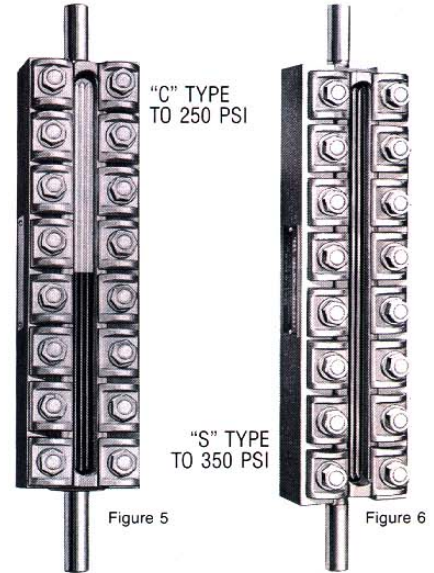

Figure 5

Figure 6

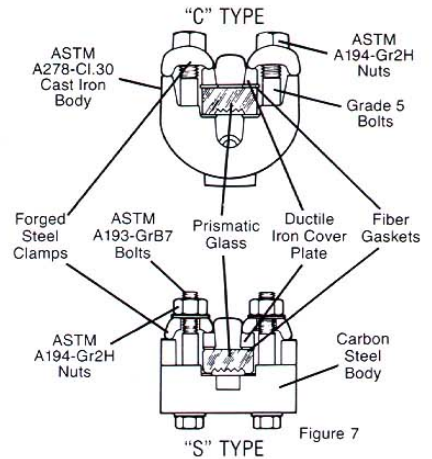

Figure 7

GAGE SELECTION DATA

Specific combinations of boiler water pressure and boiler water pH levels suggest the installation of mica-protected gages to resist gage glass deterioration and possible gage leakage.

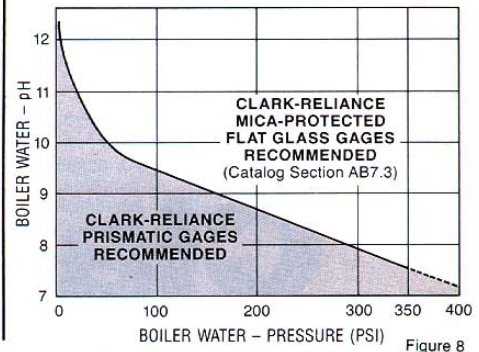

Figure 8

PRISMATIC GAGES VERTICAL ASSEMBLIES

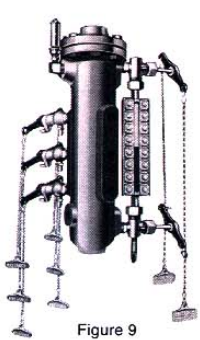

Figure 9

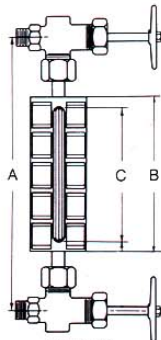

Figure 10

Vertical Centers With Reliance Valves A	Prismatic Number		Vertical Water Visibility C	Over-All Body Length B
	"C" Type	"S" Type		
14	C4	S4	6 ³ / ₈	7 ⁷ / ₈
16	C5	S5	7 ⁷ / ₈	9
17	C6	S6	9 ¹ / ₈	10 ¹ / ₄
18	C7	S7	10 ¹ / ₈	11 ³ / ₈
19	C7	S7	10 ¹ / ₈	11 ³ / ₈
19 ¹ / ₂	C8	S8	11 ³ / ₈	13
20	C9	S9	12 ¹ / ₂	13 ³ / ₄
21	C9	S9	12 ¹ / ₂	13 ³ / ₄
22	C9	S9	12 ¹ / ₂	13 ³ / ₄
23	C44	S44	14 ⁷ / ₈	16
24	C44	S44	14 ⁷ / ₈	16
25	C55	S55	17 ¹ / ₈	18 ¹ / ₄
26	C55	S55	17 ¹ / ₈	18 ¹ / ₄
27	C66	S66	19 ⁵ / ₈	20 ³ / ₄
28	C66	S66	19 ⁵ / ₈	20 ³ / ₄
29	C66	S66	19 ⁵ / ₈	20 ³ / ₄
30	C77	S77	21 ³ / ₄	23
31	C77	S77	21 ³ / ₄	23
32	C77	S77	21 ³ / ₄	23
33	C88	S88	25	26 ¹ / ₄
34	C99	S99	26 ¹ / ₂	27 ³ / ₄
30 ¹ / ₄	C444	S444	23	24 ¹ / ₈
33 ⁵ / ₈	C555	S555	26 ³ / ₈	27 ¹ / ₂
37 ³ / ₈	C666	S666	30 ¹ / ₈	31 ¹ / ₄
40 ³ / ₄	C777	S777	33 ³ / ₈	34 ⁵ / ₈
45 ⁵ / ₈	C888	S888	38 ¹ / ₄	39 ¹ / ₂
47 ⁷ / ₈	C999	S999	40 ¹ / ₂	41 ³ / ₄
38 ³ / ₈	C4444	S4444	31 ¹ / ₈	32 ¹ / ₄
42 ⁷ / ₈	C5555	S5555	35 ⁵ / ₈	36 ³ / ₄
47 ⁷ / ₈	C6666	S6666	40 ⁵ / ₈	41 ³ / ₄
52 ³ / ₈	C7777	S7777	45	46 ¹ / ₄
57 ⁷ / ₈	C8888	S8888	51 ¹ / ₂	52 ³ / ₄
61 ⁷ / ₈	C9999	S9999	54 ¹ / ₂	55 ³ / ₄

PRISMATIC GAGES TILTVIEW® ASSEMBLIES

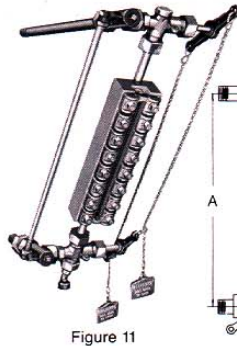

Figure 11

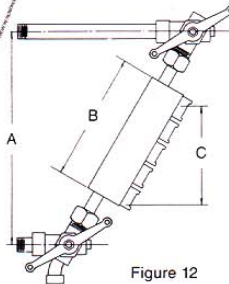

Figure 12

Vertical Centers With Reliance Valves A	Prismatic Number		Vertical Water Visibility C	Over-All Body Length B
	"C" Type	"S" Type		
15	C6	S6	7 ⁷ / ₈	10 ¹ / ₄
16	C7	S7	8 ³ / ₄	11 ³ / ₈
17	C8	S8	10 ¹ / ₄	13
18	C9	S9	10 ⁷ / ₈	13 ³ / ₄
19	C9	S9	10 ⁷ / ₈	13 ³ / ₄
20	C44	S44	12 ⁷ / ₈	16
21	C44	S44	12 ⁷ / ₈	16
22	C55	S55	14 ⁷ / ₈	18 ¹ / ₄
23	C55	S55	14 ⁷ / ₈	18 ¹ / ₄
24	C66	S66	17	20 ³ / ₄
25	C66	S66	17	20 ³ / ₄
26	C77	S77	18 ⁷ / ₈	23
27	C77	S77	18 ⁷ / ₈	23
28	C77	S77	18 ⁷ / ₈	23
29	C88	S88	21 ⁵ / ₈	26 ¹ / ₄
30	C99	S99	23	27 ³ / ₄

NOTES ON SPECIFYING CLARK-RELIANCE PRISMATIC WATER GAGES

- When specifying Prismatic Gages, refer to the Vertical Valve Center dimension "A" in the tables provided. Locate the "A" dimension that corresponds to your own gage valve centers.
- The over-all length of the Prismatic Gage, including nipples, is equal to a Tubular Glass gage length.
- A change to Prismatic Gages reduces the length of visible water range 3" to 6" depending upon gage and valve combinations.
- Nipples are 3/4" diameter. Minimum length of top nipple is 1 3/4". Minimum length of bottom nipple is 1 3/8" when Clark-Reliance bronze valves are used.

PRISMATIC GAGES REPLACING TUBULAR GLASS

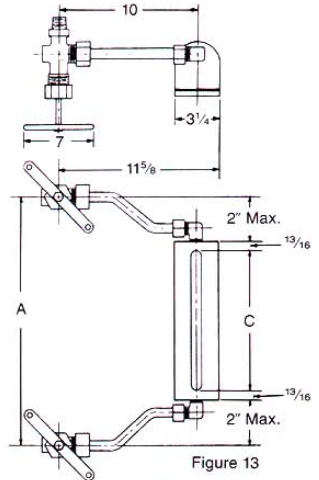

Figure 13

NOTE: When installing a Prismatic Gage to replace an existing tubular glass gage, a reduction in gage visibility can be avoided by installing an offset assembly. The offset assembly accepts a Prismatic Gage long enough to provide the necessary visibility, using valves rotated 90°. When ordering, please specify gage valve centers and Clark-Reliance Water Column and Valve part numbers.

Gage No.	C Visib.	A-Valve Centers			
		Prismatic		Flat Glass	
4	6 ³ / ₈	9 ³ / ₈	13 ³ / ₈	9 ³ / ₄	13 ³ / ₄
5	7 ⁷ / ₈	10 ¹ / ₂	14 ¹ / ₂	10 ⁷ / ₈	14 ⁷ / ₈
6	9 ¹ / ₈	11 ³ / ₄	15 ³ / ₄	12 ¹ / ₈	16 ¹ / ₈
7	10 ¹ / ₈	12 ⁷ / ₈	16 ⁷ / ₈	13 ¹ / ₈	17 ¹ / ₈
8	11 ³ / ₄	14 ¹ / ₂	18 ¹ / ₂	14 ³ / ₄	18 ³ / ₄
9	12 ¹ / ₂	15 ¹ / ₄	19 ¹ / ₄	15 ¹ / ₂	19 ¹ / ₂



Figure 14

GAGE ILLUMINATION

Gage Illuminators are a helpful option. See our Catalog Section AB8.1 for details on Clark-Reliance Illumination equipment. For any assistance in specifying, contact your nearest Clark-Reliance representative.

For additional information,
contact your local Clark-Reliance
representative

Clark-Reliance®

16633 FOLTZ INDUSTRIAL PARKWAY • STRONGSVILLE, OHIO 44136-5597 • USA
TELEPHONE: (440) 572-1500 • FACSIMILE: (440) 238-8828 • www.clark-reliance.com



NOTE: Clark-Reliance shall not be liable for damages of any kind resulting in part from failure to install its products in accordance with all applicable codes and/or state and local regulations, improper application and/or maintenance.