

Getting started

When start up the controller for the first time, it is required to enter the initial password and a new password. The initial password is 1234.

Overview

This document is a quick start guide for the UDC2800 Limit controller. For detailed instructions, see UDC2800 Limit Controller Product Manual.

To Download the Product Manual:

- In a web browser, enter <https://process.honeywell.com/us/en/support/product-documents-downloads>, and log in.
If you are a new user, register at this website first.
- In the Search box, enter **UDC2800 Limit Control Product Manual (#51-52-25-165)**, and click the Search icon.
- Select **DOCUMENT TYPE & PRODUCT** filters if required. The all search Results page appears with the search results.
- Click the package to download it.

Model Number Interpretation

Write your controller's model number in the spaces provided below and circle the corresponding items in each table. This information will also be useful when you wire your controller.

- Select the desired Key Number. The arrow to the right marks the selection available.
- Make the desired selections from Table I to Table VI. A dot '.' denotes availability.

Key Number	I	II	III	IV	V	VI
-----	--	---	---	---	--	-

Key Number – UDC2800 Single Loop Controller

Description	Selection	Availability
Digital Controller for use with 100 to 240 Vac Power	DC2800	↓
Digital Controller for use with 24 Vac/dc Power	DC2900	↓

Table I – Specify Control Output and/or Alarms

Output #1	Selection	Availability
Current Output (4 to 20ma, 0 to 20ma)	C _	• •
Electro Mechanical Relay (5 Amp Form C)	E _	• •
Open Collector transistor output	T _	• •
Dual 2 Amp Relays (Both are Form A) (Heat/Cool Applications)	R _	• •
Output #2 and Alarm #1 or Alarms 1 and 2	Selection	Availability
No Additional Outputs or Alarms	_ 0	• •
One Alarm Relay Only	_ B	• •
E-M Relay (5 Amp Form C) Plus Alarm 1 (5 Amp Form C Relay)	_ E	• •
Open Collector Plus Alarm 1 (5 Amp Form C Relay)	_ T	• •

Table II – Communications and Software

Communications	Selection	Availability
None	0 _ _	• •
Auxiliary Output/Digital Input (1 Aux and 1 DI)	1 _ _	• •
RS-485 Modbus Plus Auxiliary Output/Digital Input	2 _ _	• •
10/100M Base-T Ethernet (Modbus RTU) Plus Auxiliary Output/Digital Inputs	3 _ _	• •
Software	Selection	Availability
Limit Controller	_ L _	• •
Standard Software	_ S _	• •
Standard S/W and Set Point Programming	_ F _	• •
Future options	_ _ 0	• •

Table III – Input 1 and Input 2

Input 1	Selection	Availability
TC, RTD, mV, 0-5V, 1-5V, 0-10V	1 _ _	• •
TC, RTU, mV, 0-5V, 1-5V, 0-10V, 0-20mA, 4-20mA	2 _ _	• •
Input 2	Selection	Availability
None	_ 00	• •
TC, RTD, mV, 0-5V, 1-5V, 0-10V	_ 10	• •
TC, RTD, mV, 0-5V, 1-5V, 0-10V, 0-20mA, 4-20mA	_ 20	• •
Slidewire Input for Position Proportional (Required 2 Relay Outputs)	_ 40	A A
Carbon, Oxygen or Dewpoint (Provide 2 Inputs)	_ 60	b B

Table IV – Options

Approvals	Selection	Availability
CE (Standard)	0 _ _	• •
CE, UL and CSA	1 _ _	• •
CE, UL and CSA and FM (Limit Controller)	2 _ _	d d
Tags	Selection	Availability
None	_ 0 _	• •
Stainless Steel Customer ID Tag – 3 lines w/22 characters/line	_ T _	• •
Future options	_ _ 0	• •

Table V – Documentation

Documents	Selection	Availability
Quick Start Guide – English	0 _	• •
Certificate	Selection	Availability
None	_ 0	• •
Certificate of Conformance (F3391)	_ C	• •

Table VI – Extended Warranty

Extended Warranty	Selection	Availability
None	0	• •
Extended Warranty Additional 1 year	1	• •
Extended Warranty Additional 2 year	2	• •

Dimensions and Mounting

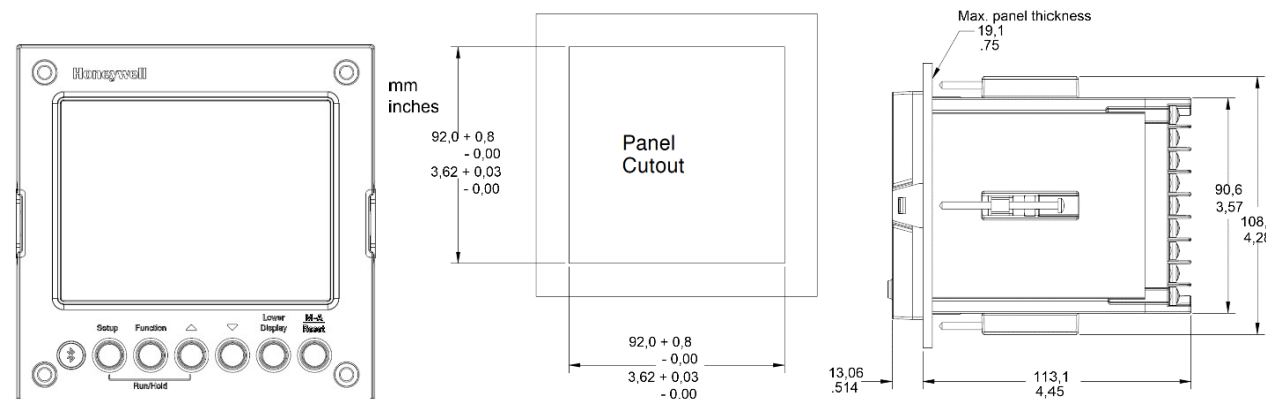

Wiring

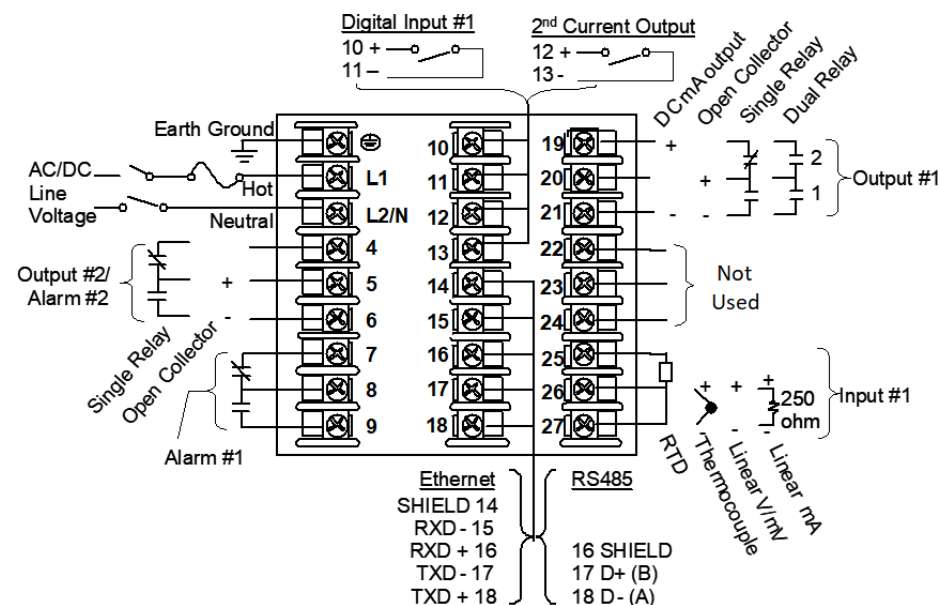

Attention: It is recommended to set up an uninterrupted power supply to avoid fluctuations on the device power line, as such fluctuations may cause device availability issues.

Configuration Procedure

Step	Operation	Press	Result
1	Enter Set Up Mode	Setup key	Enter in the first set up group, Security.
2	Select any Set Up group	Setup key or Increment or Decrement keys	Sequentially displays the other set up groups shown in the prompt hierarchy. See Configuration Record Sheet for prompts. You can also use the Increment or Decrement keys to scan the set up groups in both directions. Stop at the set up group tile that describes the group of parameters you want to configure. Then proceed to the next step.
3	Select a Function parameter	Function key Increment or Decrement keys	Enter in the first function prompt of the selected set up group. Press Increment or Decrement keys to display the other function prompts of the selected set up group. Stop at the function prompt that you want to change.
4	Change the Value or Selection	Function key Increment or Decrement keys	Enter in the value or selection of the selected function prompt. Increment or decrement the value or selection that appears for the selected function prompt. You can press the Increment and Decrement keys at the same time to move the current editable digit one step left.
5	Enter the Value or Selection	Function key	Enter value or selection made into memory.
6	Exit Configuration	Lower Display key	Exit the set up mode and returns to the main screen.

Configuration Record Sheet

Enter the value or selection for each prompt on this sheet so you will have a record of how your controller was configured.

Group Prompt	Function Prompt	Value or Selection	Factory Setting	Group Prompt	Function Prompt	Value or Selection	Factory Setting
Security	Password	-----	0	Alarms	A1S1 Type	-----	None
	Lockout	-----	Calibration		A1S1 Value	-----	90
	FM version	-----	Disable		A1S1 State	-----	High Alarm
	Restore Settings	-----	Disable		A1S1 Delay	-----	0
	Restore*	-----	Disable		A1S1 Hysteresis	-----	0.1
	Change Password	-----	--		A1S2 Type	-----	None
Limit Control	Low or High Limit	-----	High Limit		A1S2 Value	-----	10
	Power Up Status	-----	Normal		A1S2 State	-----	Low Alarm
	SP High Limit	-----	1000		A1S2 Delay	-----	0
	SP Low Limit	-----	0		A1S2 Hysteresis	-----	0.1
Input1	Input 1 Type	-----	0-10 mV		A2S1 Type	-----	None
	Input 1 Transmitter	-----	Linear		A2S1 Value	-----	95
	Input 1 High Value	-----	1000		A2S1 State	-----	High Alarm
	Input 1 Low Value	-----	0		A2S1 Delay	-----	0
	Input 1 Bias	-----	0		A2S1 Hysteresis	-----	0.1
	Input 1 Filter	-----	1		A2S2 Type	-----	None
	Input 1 Burnout	-----	No Burnout	A2S2 Value	-----	5	
Options	Auxiliary Output	-----	Disable	A2S2 State	-----	Low Alarm	
	DI 1 Function	-----	None	A2S2 Delay	-----	0	
Display	Decimal Digits	-----	None	A2S2 Hysteresis	-----	0.1	
	Temperature Unit	-----	None	Alarm Output 1	-----	Non Latching	
	Language	-----	English	Alarm Blocking	-----	Disable	
	TC Diagnostics	-----	Enable	AO/CO Diagnostic	-----	Disable	
	Theme	-----	White/Black				
	Display Brightness	-----	50				

Configuration Record Sheet

Group Prompt	Function Prompt	Value or Selection	Factory Setting
Communication	Bluetooth Function	-----	Disable
	Bluetooth ID	-----	UXXXXXXXX
	Bluetooth MAC Address	-----	XX:XX:XX:XX:XX:XX
	Communication Type	-----	Disable
	Modbus Address	-----	3
	Baud Rate	-----	19200
	Response Delay	-----	1
	Word Order for Float	-----	FP B 0123
	Ethernet Address	-----	10.0.0.2
	Subnet Mask Address	-----	255.255.255.0
	Default Gateway	-----	0.0.0.0
	Shed Function	-----	Disable
	Shed Time	-----	30
	Shed Mode	-----	Last Mode
Communication with RS485 board (Accessible via Communication set up group or Honeywell EasySet)	Bluetooth Function	-----	Disable
	Bluetooth ID	-----	UXXXXXXXX
	Bluetooth MAC Address	-----	XX:XX:XX:XX:XX:XX
	Communication Type	-----	Disable
	Modbus Address	-----	3
	Baud Rate	-----	19200
	Response Delay	-----	1
	Word Order for Float	-----	FP B 0123
	Shed Function	-----	Disable
	Shed Time	-----	30
	Shed Mode	-----	Last Mode
	Shed SP Recall	-----	To Local SP
	Computer SP Unit	-----	Engineering Unit
	Computer SP Ratio	-----	1.00
Computer SP Bias	-----	0	
Communication with Ethernet board (Accessible via Communication set up group or Honeywell EasySet)	Bluetooth Function	-----	Disable
	Bluetooth ID	-----	UXXXXXXXX
	Bluetooth MAC Address	-----	XX:XX:XX:XX:XX:XX
	Communication Type	-----	Disable
	Modbus Address	-----	3
	Baud Rate	-----	19200
	Response Delay	-----	1
	Word Order for Float	-----	FP B 0123
	Ethernet Address	-----	10.0.0.2
	Subnet Mask Address	-----	255.255.255.0
	Default Gateway	-----	0.0.0.0
	Shed Function	-----	Disable
	Shed Time	-----	30
	Shed Mode	-----	Last Mode
Shed SP Recall	-----	To Local SP	
Computer SP Unit	-----	Engineering Unit	
Computer SP Ratio	-----	1.00	
Computer SP Bias	-----	0	
Status	Software Version	Read only	--

Start Up Procedure for Operation

It is required to enter the initial password and a new password when start up the controller for the first time. The initial password is 1234. For more information of interface displays, see "Function of displays" in *UDC2800 Product Manual*.

Step	Operation	Press	Result
3	Enter the Local Setpoint	Lower Display key	Until the required "SP" and the Local Setpoint Value are displayed.
		Increment or Decrement keys	To adjust the local setpoint to the value at which you want the process variable maintained. Attention: The local setpoint 1 cannot be changed if the Setpoint Ramp function is running.

Setpoints

You can configure the following setpoints for the UDC2800 controller.

- A Single Local Setpoint

Changing the Setpoint value

Step	Operation	Press	Result
1	Select the Setpoint	Low Display key	Until you see: Lower Display = SP
2	Adjust the Output	Increment or Decrement keys	To change the Local Setpoint to the value at which you want the process maintained. The display "blinks" if you attempt to enter setpoint values beyond the high and low limits. The configured setpoint will be stored immediately.

Viewing the operating parameters

Under the main screen, press the Lower Display key to scroll through the operating parameters listed in table below. The lower display will show only those parameters and their values that apply to your specific model.

Lower Display	Description
SP XXXX.XXX	Local Setpoint #1, appears when Control Algorithm is configured as ANY algorithm except Disable in the Algorithms set up group. It also appears for current setpoint when using SP Ramp.
CSP XXXX.XXX	Computer Setpoint, when SP is in override. <ul style="list-style-type: none"> In the Algorithms set up group, configure Control Algorithm as ANY algorithm except Disable. In the Communication set up group, enable Shed Function. And CSP is successfully override by SP override through Modbus.

Notices

This document contains Honeywell proprietary information. Information contained herein is to be used solely for the purpose submitted, and no part of this document or its contents shall be reproduced, published, or disclosed to a third party without the express permission of Honeywell International Sàrl.

While this information is presented in good faith and believed to be accurate, Honeywell disclaims the implied warranties of merchantability and fitness for a purpose and makes no express warranties except as may be stated in its written agreement with and for its customer.

In no event is Honeywell liable to anyone for any direct, special, or consequential damages. The information and specifications in this document are subject to change without notice.

Copyright 2025 - Honeywell International Sàrl

Trademarks

Honeywell®, Experion®, PlantScape®, SafeBrowse®, and TotalPlant® are registered trademarks of Honeywell International, Inc.

Other brand or product names are trademarks of their respective owners.

Other trademarks

Microsoft and SQL Server are either registered trademarks or trademarks of Microsoft Corporation in the United States and/or other countries.

Trademarks that appear in this document are used only to the benefit of the trademark owner, with no intention of trademark infringement.

Third-party licenses

This product may contain or be derived from materials, including software, of third parties. The third party materials may be subject to licenses, notices, restrictions and obligations imposed by the licensor. The licenses, notices, restrictions and obligations, if any, may be found in the materials accompanying the product, in the documents or files accompanying such third party materials, in a file named third-party_licenses on the media containing the product, or at <http://www.honeywell.com/en-us/privacy-statement>.

Support

For support, contact your local Honeywell Process Solutions Customer Contact Center (CCC). To find your local CCC visit the website, <https://www.honeywellprocess.com/en-US/contactus/customer-support-contacts/Pages/default.aspx>.

How to report a security vulnerability

For the purpose of submission, a security vulnerability is defined as a software defect or weakness that can be exploited to reduce the operational or security capabilities of the software.

Honeywell investigates all reports of security vulnerabilities affecting Honeywell products and services.

To report a potential security vulnerability against any Honeywell product, please follow the instructions at: <https://www.honeywell.com/en-us/product-security>.

Documentation feedback

You can find the most up-to-date documents on the Honeywell Process Solutions Support website at: www.honeywellprocess.com.

If you have comments about Honeywell Process Solutions documentation, send your feedback to: hpsdocs@Honeywell.com.

Use this email address to provide feedback, or to report errors and omissions in the documentation. For immediate help with a technical problem, contact HPS Technical Support through your local Customer Contact Center, or by raising a support request on the Honeywell Process Solutions Support website.

Training classes

Honeywell holds technical training classes that are taught by process control systems experts. For more information about these classes, contact your Honeywell representative, or see <http://www.automationcollege.com>.

Factory Information

Company Name: HONEYWELL System Sensor de Mexico, S. de R.L. de C.V. .

Company Address: Avenida Miguel De La Madrid, #8102 Colonia Lote Bravo Ciudad Juarez, Chihuahua, C.P. 32695, México