

Getting started

When start up the controller for the first time, it is required to enter the initial password and a new password. The initial password is 1234.

Overview

This document is a quick start guide for UDC2800 controller. For detailed instructions, see UDC2800 Product Manual.

To Download the Product Manual:

- In a web browser, enter <https://process.honeywell.com/us/en/support/product-documents-downloads>, and login.
If you are a new user, register at this website first.
- In the Search box, enter **UDC2800 Product Manual (#51-52-25-157)**, and click the Search icon.
- Select **DOCUMENT TYPE & PRODUCT** filters, if required. The All search Results page appears with the search results.
- Click the package to download it.

Model Number Interpretation

Write your controller's model number in the spaces provided below and circle the corresponding items in each table. This information will also be useful when you wire your controller.

Instructions

- Select the desired key number. The arrow to the right marks the selection available.
- Make the desired selections from Tables I through VI using the column below the proper arrow. A dot (•) denotes availability.

Key Number	I	II	III	IV	V	VI
_____	_____	_____	_____	_____	_____	_____



KEY NUMBER

Description	Selection	Availability
Digital Controller for use with 100 to 240Vac Power	DC2800	↓
Digital Controller for use with 24Vac/dc Power	DC2900	↓

Selection	Availability
DC2800	↓
DC2900	↓

TABLE I - Specify Control Output and/or Alarms

Output #1	Description
Output #1	Current Output (4 to 20ma, 0 to 20 ma) Electro Mechanical Relay (5 Amp Form C) Open Collector transistor output Dual 2 Amp Relays (Both are Form A) (Heat/Cool Applications)
Output #2 and Alarm #1 or Alarms 1 and 2	No Additional Outputs or Alarms One Alarm Relay Only E-M Relay (5 Amp Form C) Plus Alarm 1 (5 Amp Form C Relay) Open Collector Plus Alarm 1 (5 Amp Form C Relay)

Selection	Availability
C	*
E	*
T	*
R	*
0	*
B	*
E	*
T	*

TABLE II - Communications and Software

Communications	Description
Communications	None Auxiliary Output/Digital Inputs (1 Aux and 1 DI or 2 DI) RS-485 Modbus Plus Auxiliary Output/Digital Inputs 10/100M Base-T Ethernet (Modbus RTU) Plus Auxiliary Output/Digital Inputs
Software	Limit Controller Standard Software Dual Loop and Internal Cascade Control Standard S/W and Set Point Programming
Future Options	None

Selection	Availability
0	*
1	*
2	*
3	*
L	e
S	*
D	*
F	*
0	*

TABLE III - Input 1 and Input 2

Input 1 (Note 1)	Description
Input 1 (Note 1)	TC, RTD, mV, 0-5V, 1-5V, 0-10V TC, RTD, mV, 0-5V, 1-5V, 0-10V, 0-20mA, 4-20mA
Input 2	None TC, RTD, mV, 0-5V, 1-5V, 0-10V TC, RTD, mV, 0-5V, 1-5V, 0-10V, 0-20mA, 4-20mA Slidewire Input for Position Proportional (Requires 2 Relay Outputs) Carbon, Oxygen or Dewpoint (Provides 2 Inputs)

Selection	Availability
1	*
2	*
00	*
10	*
20	*
40	a
60	b

Note 1: Input 1 can be changed in the field using external resistors.

TABLE IV - Options

Approvals	Description
Approvals	CE (Standard) CE, UL, and CSA
Tags	None Stainless Steel Customer ID Tag - 3 lines w/22 characters/line
Future Options	None

Selection	Availability
0	*
1	*
0	*
T	*
0	*

TABLE V - Documentation

Documents	Description
Documents	Quick Start Guide - English
Certificate	None Certificate of Conformance (F3391)

Selection	Availability
0	*
0	*
C	*

TABLE VI - Extended Warranty

Extended Warranty	Description
Extended Warranty	None Extended Warranty Additional 1 year Extended Warranty Additional 2 years

Selection	Availability
0	*
1	*
2	*

Dimensions and Mounting

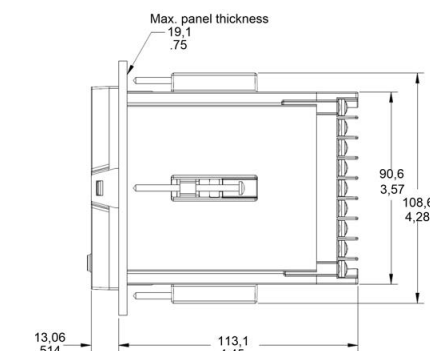
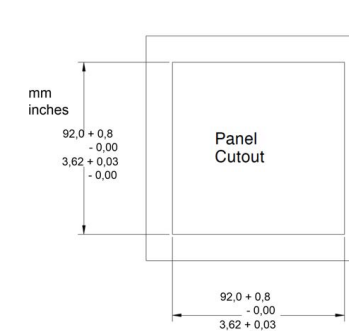
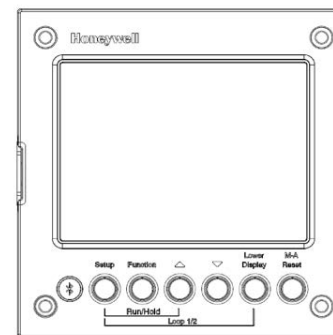

Wiring

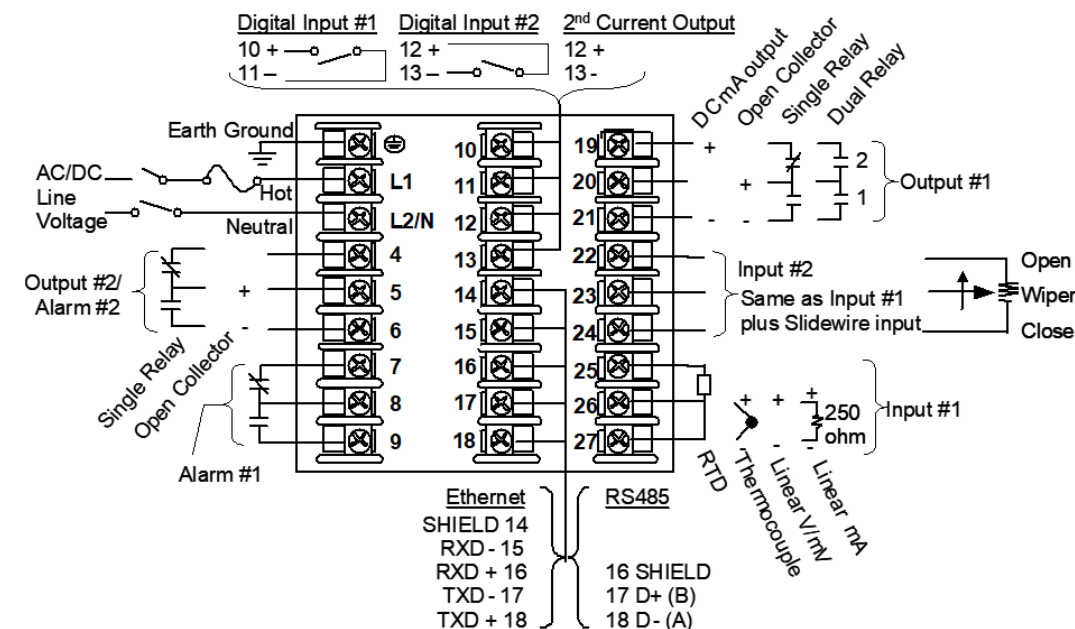

Attention: It is recommended to set up an uninterrupted power supply to avoid fluctuations on the device power line, as such fluctuations may cause device availability issues.

Configuration Procedure

Step	Operation	Press	Result
1	Enter Set Up Mode	Setup key	Enter in the first set up group, Security.
2	Select any Set Up group	Setup key or Increment or Decrement keys	Sequentially displays the other set up groups shown in the prompt hierarchy. See Configuration Record Sheet for prompts. You can also use the Increment or Decrement keys to scan the set-up groups in both directions. Stop at the set-up group tile that describes the group of parameters you want to configure. Then proceed to the next step.
3	Select a Function parameter	Function key Increment or Decrement keys	Enter in the first function prompt of the selected set up group. Press Increment or Decrement keys to display the other function prompts of the selected set up group. Stop at the function prompt that you want to change.
4	Change the Value or Selection	Function key Increment or Decrement keys	Enter in the value or selection of the selected function prompt. Increment or decrement the value or selection that appears for the selected function prompt. You can press the Increment and Decrement keys at the same time to move the current editable digit one step left.
5	Enter the Value or Selection	Function key	Enter value or selection made into memory.
6	Exit Configuration	Lower Display key	Exit the set-up mode and returns to the main screen.

Configuration Record Sheet

Enter the value or selection for each prompt on this sheet so you will have a record of how your controller was configured.

Group Prompt	Function Prompt	Value or Selection	Factory Setting	Group Prompt	Function Prompt	Value or Selection	Factory Setting	
Security	Password	_____	0	Accutune	Fuzzy Suppression	_____	Disable	
	Lockout	_____	Calibration		Accutune	_____	Disable	
	Auto/Man Key	_____	Enable		Duplex Output	_____	Manual	
	Run/Hold Key	_____	Enable		Accutune 2	_____	Disable	
	SP Select Key	_____	Enable		Duplex Output 2	_____	Manual	
	Restore Settings	_____	Disable		Error Status	Read Only	None	
	Restore*	_____	Disable		Error Status 2	Read Only	None	
	Change Password	_____	--					
Tuning	Proportional Band 1	_____	--	Tuning 2	Proportional Band 5	_____	--	
	or				or			
	Gain 1	_____	1		Gain 5	_____	1	
	or				or			
	Rate Min	_____	0		Rate Min	_____	0	
	Reset Mins/Rpt 1	_____	1		Reset Mins/Rpt 5	_____	1	
	or				or			
	Reset Rpts/Min 1	_____	--		Reset Rpts/Min 5	_____	--	
	Manual Reset	_____	0		Manual Reset	_____	0	
	Proportional Band 2	_____	--		Proportional Band 6	_____	--	
	or				or			
	Gain 2	_____	1		Gain 6	_____	1	
	Rate 2 Min	_____	0		Rate 6 Min	_____	0	
	Reset Mins/Rpt 2	_____	1		Reset Mins/Rpt 6	_____	1	
	or				or			
	Reset Rpts/Min 2	_____	--		Reset Rpts/Min 6	_____	--	
	Proportional Band 3	_____	--		Proportional Band 7	_____	--	
	or				or			
	Gain 3	_____	1		Gain 7	_____	1	
	Rate 3 Min	_____	0		Rate 7 Min	_____	0	
	Reset Mins/Rpt 3	_____	1		Reset Mins/Rpt 7	_____	1	
	or				or			
	Reset Rpts/Min 3	_____	--		Reset Rpts/Min 7	_____	--	
	Proportional Band 4	_____	--		Proportional Band 8	_____	--	
	or				or			
	Gain 4	_____	1		Gain 8	_____	1	
	Rate 4 Min	_____	0		Rate 8 Min	_____	0	
	Reset Mins/Rpt 4	_____	1		Reset Mins/Rpt 8	_____	1	
or			or					
Reset Rpts/Min 4	_____	--	Reset Rpts/Min 8	_____	--			
Cycle Time 1 Sec	_____	20	Cycle Time 5 Sec	_____	20			
Cycle Time 2 Sec	_____	20	Cycle Time 6 Sec	_____	20			
Options	Auxiliary Output	_____	Disable	Display	Decimal Digits	_____	None	
	CO Range	_____	4-20 mA		Decimal Digits Loop 2	_____	None	
	CO Low Value	_____	0		Temperature Unit	_____	None	
	CO High Value	_____	100		Input 2 Ratio	_____	Disable	
	DI 1 Function	_____	None		Language	_____	English	
	DI 1 Combination	_____	Disable		TC Diagnostics	_____	Enable	
	DI 2 Function	_____	None		Theme	_____	White	
	DI 2 Combination	_____	Disable		Display Brightness (For New Display)	_____	50	
	DI on Loop 2	_____	Disable					

Group Prompt	Function Prompt	Value or Selection	Factory Setting	Group Prompt	Function Prompt	Value or Selection	Factory Setting	
Algorithms	Control Algorithm	_____	PID A	SR Ramp/Program	SP Ramp Function	_____	Disable	
	PID Loops	_____	1 Loop		Ramp Time Min	_____	3	
	Control Algorithm 2	_____	PID A		Ramp Final SP	_____	1000	
	Output Override	_____	Disable		SP Rate Function	_____	Disable	
	Timer Function	_____	Disable		Rate Up EU/HRr	_____	0	
	Period Hrs:Mins	_____	0.01		Rate Down EU/HR	_____	0	
	Start Trigger	_____	Keyboard		Rate Up EU/HRr Loop2	_____	0	
	Low Display	_____	Timer Remaining		Rate Down EU/HR Loop2	_____	0	
	Reset Trigger	_____	Keyboard		SP Program Function	_____	Disable	
	Increment	_____	Minutes		Soak Deviation	_____	0	
	Input Algorithm 1	_____	None		Program Termination	_____	Last SP	
	Math K	_____	1		Program End State	_____	Disable	
	Calculated High	_____	1000		Key Reset/Rerun	_____	Disable	
	Calculated Low	_____	0		Hot Start	_____	Disable	
	Algorithm 1 Input A	_____	Input 1					
	Algorithm 1 Input B	_____	Input 2					
	Algorithm 1 Input C	_____	None					
	Percent CO	_____	0.2					
Algorithm 1 Bias	_____	0						
Percent H2	_____	1						
Control	PV Source	_____	Input 1	Control 2	PV Source	_____	Input 1	
	PID Sets	_____	1 Set		Link Loops	_____	Disable	
	Switchover Value 1/2	_____	0		PID Sets	_____	1 Set	
	Switchover Value 2/3	_____	0		Switchover Value 1/2	_____	0	
	Switchover Value 3/4	_____	0		Switchover Value 2/3	_____	0	
	Local SP Source	_____	1 Local SP		Switchover Value 3/4	_____	0	
	Remote SP Source	_____	None		Local SP Source	_____	1 Local SP	
	Autobias	_____	Disable		Remote SP Source	_____	None	
	SP Tracking	_____	None		Autobias	_____	Disable	
	Power Up Mode	_____	Manual/Local SP		SP Tracking	_____	None	
	TPSC Power Up Mode	_____	Failsafe		Power Up Mode	_____	Manual/Local SP	
	SP High Limit	_____	1000		SP High Limit	_____	1000	
	SP Low Limit	_____	0		SP Low Limit	_____	0	
	Action Direction	_____	Reverse		Action Direction	_____	Reverse	
	Output Rate	_____	Disable		Output Rate	_____	Disable	
	Rate Up % Min	_____	0		Rate Up % Min	_____	0	
	Rate Down % Min	_____	0		Rate Down % Min	_____	0	
	Output High Limit	_____	100		Output High Limit	_____	100	
	Output Low Limit	_____	0		Output Low Limit	_____	0	
	Integral High Limit	_____	100		Integral High Limit	_____	100	
	Integral Low Limit	_____	0		Integral Low Limit	_____	0	
Dropoff	_____	0	Dropoff	_____	0			
Deadband	_____	1	Deadband	_____	1			
Output Hysteresis	_____	0.5	Failsafe Mode	_____	Non Latching			
Failsafe Mode	_____	Non Latching	Failsafe Value	_____	1			
Failsafe Value	_____	1	Preset Manual Output	_____	0			
SW Failsafe Value	_____	--	Preset Auto Output	_____	0			
Preset Manual Output	_____	0	Proportion Unit	_____	Gain			
Preset Auto Output	_____	0	Reset Unit	_____	Minutes/Repeat			
Proportion Unit	_____	Gain						
Reset Unit	_____	Minutes/Repeat						
Input 1	Input 1 Type	_____	0-10 mV	Input 2	Input 2 Type	_____	0-10 mV	
	Input 1 Transmitter	_____	Linear		Input 2 Transmitter	_____	Linear	
	Input 1 High Value	_____	1000		Input 2 High Value	_____	1000	
	Input 1 Low Value	_____	0		Input 2 Low Value	_____	0	
	Input 1 Ratio	_____	1		Input 2 Ratio	_____	1	
	Input 1 Bias	_____	0		Input 2 Bias	_____	0	
	Input 1 Filter	_____	1		Input 2 Filter	_____	1	
Input 1 Burnout	_____	No Burnout	Input 2 Burnout	_____	No Burnout			

Group Prompt	Function Prompt	Value or Selection	Factory Setting	Group Prompt	Function Prompt	Value or Selection	Factory Setting
Alarms	A1S1 Type	_____	None	Communication	Bluetooth Function	_____	Disable
	A1S1 Value	_____	90		Bluetooth ID	Read only	UXXXXXXXX
	A1S1 State	_____	High Alarm		Bluetooth MAC Address	Read only	XX:XX:XX:XX:XX:XX
	A1S1 Event	_____	End of Segment		Communication Type	_____	Disable
	A1S1 Delay	_____	0		Modbus Address	_____	3
	A1S1 Hysteresis	_____	0.1		Baud Rate	_____	19200
	A1S2 Type	_____	None		Response Delay	_____	1
	A1S2 Value	_____	10		Word Order for Float	_____	FP B 0123
	A1S2 State	_____	Low Alarm		Ethernet Address	_____	10.0.0.2
	A1S2 Event	_____	Begin of Segment		Subnet Mask Address	_____	255.255.255.0
	A1S2 Delay	_____	0		Default Gateway	_____	0.0.0.0
	A1S2 Hysteresis	_____	0.1		Shed Function	_____	Disable
	A2S1 Type	_____	None		Shed Time	_____	30
	A2S1 Value	_____	95		Shed Mode	_____	Last Mode
	A2S1 State	_____	High Alarm		Shed SP Recall	_____	To Local SP
	A2S1 Event	_____	End of Segment		Computer SP Unit	_____	Engineering Unit
	A2S1 Delay	_____	0		Computer SP Ratio	_____	1
	A2S1 Hysteresis	_____	0.1		Computer SP Bias	_____	0
	A2S2 Type	_____	None		Computer SP Ratio 2	_____	1
	A2S2 Value	_____	5		Computer SP Bias 2	_____	0
	A2S2 State	_____	Low Alarm		Local Loopback	_____	Disable
	A2S2 Event	_____	Begin of Segment				
	A2S2 Delay	_____	0				
	A2S2 Hysteresis	_____	0.1				
	Alarm Output 1	_____	Non Latching				
	Alarm Blocking	_____	Disable				
	AO/CO Diagnostic	_____	Disable				
	Communication with Ethernet board (Accessible via Communication set up group or Honeywell EasySet)	Bluetooth Function	_____		Disable	Communication with RS485 board (Accessible via Communication set up group or Honeywell EasySet)	Bluetooth Function
Bluetooth ID		Read only	UXXXXXXXX	Bluetooth ID	Read only		UXXXXXXXX
Bluetooth MAC Address		Read only	XX:XX:XX:XX:XX:XX	Bluetooth MAC Address	Read only		XX:XX:XX:XX:XX:XX
Communication Type		_____	Disable	Communication Type	_____		Disable
Modbus Address		_____	3	Modbus Address	_____		3
Baud Rate		_____	19200	Baud Rate	_____		19200
Response Delay		_____	1	Response Delay	_____		1
Word Order for Float		_____	FP B 0123	Word Order for Float	_____		FP B 0123
Ethernet Address		_____	10.0.0.2	Shed Function	_____		Disable
Subnet Mask Address		_____	255.255.255.0	Shed Time	_____		30
Default Gateway		_____	0.0.0.0	Shed Mode	_____		Last Mode
Shed Function		_____	Disable	Shed SP Recall	_____		To Local SP
Shed Time		_____	30	Computer SP Unit	_____		Engineering Unit
Shed Mode		_____	Last Mode	Computer SP Ratio	_____		1
Shed SP Recall		_____	To Local SP	Computer SP Bias	_____		0
Computer SP Unit		_____	Engineering Unit	Local Loopback	_____		Disable
Computer SP Ratio	_____	1					
Computer SP Bias	_____	0					
Status	Software Version	Read only	--				
	Failsafe Status	Read only	--				
	Failsafe Status Loop 2	Read only	--				
	Self Tests	Read Only	--				

Start Up Procedure for Operation

It is required to enter the initial password and a new password when start up the controller for the first time. The initial password is 1234. For more information of interface displays, see "Function of displays" in *UDC2800 Product Manual*.

Step	Operation	Press	Result
1	Select Manual Mode	Man Auto key	Until "Manual" is displayed under MODE. The controller is in manual mode.
2	Adjust the Output	Increment or Decrement keys	Lower Display = OUT and the output value in %. To adjust the output value and ensure that the final control element is functioning correctly.
3	Enter the Local Setpoint	Lower Display key	Until the required "SP" and the Local Setpoint Value are displayed.
		Increment or Decrement keys	To adjust the local setpoint to the value at which you want the process variable maintained. Attention: The local setpoint 1 cannot be changed if the Setpoint Ramp function is running.
4	Select Automatic Mode	Man Auto key	Until "Auto" is displayed under MODE. The controller is in Automatic mode. The controller will automatically adjust the output to maintain the process variable at setpoint.
5	Tune the Controller	Setup key	Make sure the controller has been configured properly and all the values and selections have been recorded on the Configuration Record Sheet. Refer to Tuning Set Up group to ensure that the selections for Proportional Band or Gain, Rate Min, and Reset Mins/Rpt, or Reset Rpts/Min have been entered. Use Accutune to tune the controller. See "Accutune III" in <i>UDC2800 Product Manual</i> .

Setpoints

You can configure the following setpoints for the UDC2800 controller.

- A Single Local Setpoint
- 2 Local Setpoints
- 3 Local Setpoints
- 4 Local Setpoints
- Up to 4 Local Setpoints and 1 Remote Setpoint

Changing the Setpoint value

Step	Operation	Press	Result
1	Select the Setpoint	Low Display key	Until you see: Lower Display = SP or 2SP or 3SP, or 4SP (Value)
2	Adjust the Output	Increment or Decrement keys	To change the Local Setpoint to the value at which you want the process maintained. The display "blinks" if you attempt to enter setpoint values beyond the high and low limits. The configured setpoint will be stored immediately.

Switching between Setpoints

You can switch Local and Remote setpoints or between two Local setpoints when configured.

Attention: The Remote Setpoint value cannot be changed at the keyboard.

To switch between Setpoints

Press the Function key to switch the four Local Setpoints and/or the Remote Setpoint.

Attention: "KEY ERROR" appears if:

- the remote setpoint or additional local setpoints are not configured as a setpoint source.
- you attempt to change the setpoint while a setpoint ramp/program is running.
- you attempt to change the setpoint with the setpoint select function key disabled.
- while a setpoint ramp/program is not terminated.

Viewing the operating parameters

Under the main screen, press the Lower Display key to scroll through the operating parameters listed in table below. The lower display will show only those parameters and their values that apply to your specific model.

Lower Display	Description
OUT XXX.X	Output value is shown in percent with one decimal point when Control Algorithm is NOT configured as Three Position Step Control (TPSC), and Slidewire is connected.
OUT XXX	Output value is shown in percent with no decimal point when Control Algorithm is NOT configured as Three Position Step Control (TPSC), Output Algorithm is configured as Position Proportion, and Slidewire fails.
COUT XXX.X	Appears when Shed function is Enabled, and Output Override register is successful override by Modbus (In Slave Mode).
EOUT XXX.X	Appears when Shed function is Enabled, and the controller is in Slave Mode, push A/M key to enter Emergency Mode.
POS XXX	Slidewire Position – Used only with TPSC applications that use a slidewire input.
SP XXXX.XXX	Local Setpoint #1, appears when Control Algorithm is configured as ANY algorithm except Disable in the Algorithms set up group. It also appears for current setpoint when using SP Ramp.
2SP XXXX.XXX	Local Setpoint #2, appears when the following two conditions are satisfied: <ul style="list-style-type: none"> In the Algorithms set up group, configure Control Algorithm as ANY algorithm except Disable. In the Control set up group, configure Local SP Source as 2/3/4 Local SPs.
3SP XXXX.XXX	Local Setpoint #3, appears when the following two conditions are satisfied: <ul style="list-style-type: none"> In the Algorithms set up group, configure Control Algorithm as ANY algorithm except Disable. In the Control set up group, configure Local SP Source as 3/4 Local SPs.
4SP XXXX.XXX	Local Setpoint #4, appears when the following two conditions are satisfied: <ul style="list-style-type: none"> In the Algorithms set up group, configure Control Algorithm as ANY algorithm except Disable. In the Control set up group, configure Local SP Source as 4 Local SPs.
RSP XXXX.XXX	Remote Setpoint, appears when the following two conditions are satisfied: <ul style="list-style-type: none"> In the Algorithms set up group, configure Control Algorithm as ANY algorithm except Disable. In the Control set up group, configure Remote SP Source as ANY selection except Disable.
CSP XXXX.XXX	Computer Setpoint when SP is in override. <ul style="list-style-type: none"> In the Algorithms set up group, configure Control Algorithm as ANY algorithm except Disable. In the Communication set up group, enable Shed Function. And CSP is successfully override by SP override through Modbus.
SPN XXXX.XXX	Setpoint Now—Current Setpoint when SP Rate is enabled. The SP XXXX.XXX display shows the “target” or final setpoint value. SPN is not equal with the target SP.
DEV XXX.X	Deviation
1 IN XXXX.XXX	Input 1—Used only with combinational input algorithms.
2 IN XXXX.XXX	Input 2
PID Set X	Tuning Parameter, where X is either 1, 2, 3 or 4.
BIAS XXXX	BIAS, displays the manual reset value for algorithm PD+MR.
OTI XX.X	OUTPUT OVERRIDE (2 PID LOOPS ONLY)—Appears when internal loop 1 output value is displayed, this represents the internal output 1 value before override.
AUX XXX.X	Auxiliary Output, displayed only when output algorithm is not Current Duplex.
TEL O XXH: XXM Or TEL O XXM: XXS	Elapsed Time, time that has elapsed on the Timer in Hours: Minutes, or Minutes: Seconds. The “O” is a clockwise running clock.
TRE O XXH: XXM Or TRE O XXM: XXS	Time Remaining, time remaining on the Timer in Hours: Minutes, or Minutes: Seconds. The “O” is a counter clockwise running clock.
RAMP XXXM: XXS	Setpoint Ramp Time—Time remaining in the Setpoint Ramp in minutes.
PXSX RA XXH:XXM:XXS PXSX RA XXX/M (0-999) PXSX RA XXX/H (0-999)	Program X (1-8) Segment X (1-8) Ramp XXH:XXM:XXS remaining X and XX is current program or segment or time remaining Initial hold states Ramp time should be remaining time
PXSX SK XXH:XXM:XXS	Program X (1-8) Segment (1-8) Soak XXH:XXM:XXS remaining X and XX is current program or segment or time remaining Initial hold states Soak time should be remaining time
Recycle XX	Number of SP Program Recycles Remaining
To Begin	Reset SP Program to Start of First Segment
Rerun	Reset SP Program to Start of Current Segment
ACTU TUNE OFF	Limit Cycle Tuning Not Running, appears when Accutune is enabled but not operating.
ACTU DO SLOW	Limit Cycle Tuning with the objective of producing damped or Dahlin tuning parameters, depending upon the detected process deadtime. The tuning parameters calculated by this selection are aimed at reducing PV overshoot of the SP setting.
ACTU DO FAST	Limit Cycle Tuning with the objective of producing quarter-damped tuning parameters. This tuning may result in PV overshoot of the SP setting.

Notices

This document contains Honeywell proprietary information. Information contained herein is to be used solely for the purpose submitted, and no part of this document or its contents shall be reproduced, published, or disclosed to a third party without the express permission of Honeywell International Sàrl.

While this information is presented in good faith and believed to be accurate, Honeywell disclaims the implied warranties of merchantability and fitness for a purpose and makes no express warranties except as may be stated in its written agreement with and for its customer.

In no event is Honeywell liable to anyone for any direct, special, or consequential damages. The information and specifications in this document are subject to change without notice.

Copyright 2022 – Honeywell International Sàrl

Trademarks

Honeywell®, Experion®, PlantScape®, SafeBrowse®, and TotalPlant® are registered trademarks of Honeywell International, Inc.

Other brand or product names are trademarks of their respective owners.

Other trademarks

Microsoft and SQL Server are either registered trademarks or trademarks of Microsoft Corporation in the United States and/or other countries.

Trademarks that appear in this document are used only to the benefit of the trademark owner, with no intention of trademark infringement.

Third-party licenses

This product may contain or be derived from materials, including software, of third parties. The third party materials may be subject to licenses, notices, restrictions and obligations imposed by the licensor. The licenses, notices, restrictions and obligations, if any, may be found in the materials accompanying the product, in the documents or files accompanying such third party materials, in a file named third_party_licenses on the media containing the product, or at <http://www.honeywell.com/en-us/privacy-statement>.

Support

For support, contact your local Honeywell Process Solutions Customer Contact Center (CCC). To find your local CCC visit the website, <https://www.honeywellprocess.com/en-US/contactus/customer-support-contacts/Pages/default.aspx>.

How to report a security vulnerability

For the purpose of submission, a security vulnerability is defined as a software defect or weakness that can be exploited to reduce the operational or security capabilities of the software.

Honeywell investigates all reports of security vulnerabilities affecting Honeywell products and services.

To report a potential security vulnerability against any Honeywell product, please follow the instructions at: <https://www.honeywell.com/en-us/product-security>.

Documentation feedback

You can find the most up-to-date documents on the Honeywell Process Solutions Support website at: www.honeywellprocess.com.

If you have comments about Honeywell Process Solutions documentation, send your feedback to: hpsdocs@Honeywell.com.

Use this email address to provide feedback, or to report errors and omissions in the documentation. For immediate help with a technical problem, contact HPS Technical Support through your local Customer Contact Center, or by raising a support request on the Honeywell Process Solutions Support website.

Training classes

Honeywell holds technical training classes that are taught by process control systems experts. For more information about these classes, contact your Honeywell representative, or see <http://www.automationcollege.com>.

Factory Information

Company Name: HONEYWELL System Sensor de Mexico, S. de R.L. de C.V .

Company Address: Avenida Miguel De La Madrid, #8102 Colonia Lote Bravo Ciudad Juarez, Chihuahua, C.P. 32695, México