

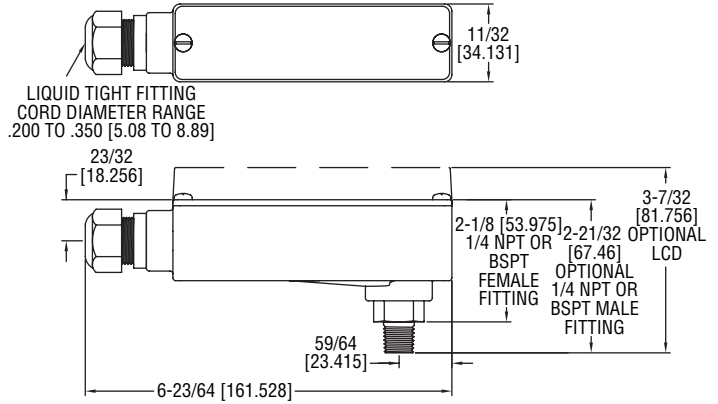

Series 626/628-CB Industrial Pressure Transmitters

Specifications - Installation and Operating Instructions



The **SERIES 626 AND 628** Pressure Transmitters monitors the pressure of compatible gases and liquids with 0.25% FS accuracy for 626 models or 1.0% FS accuracy for 628 models. The design employs a pressure sensor that can convert a single positive pressure into a standard 4 to 20 mA output or field selectable voltage output. The terminal block, as well as a zero adjustment button, are easily accessed under the top cover. The Series 626 and 628 are designed to meet NEMA 4X (IP66) construction.

SPECIFICATIONS

Service: Compatible gases and liquids.
Wetted Materials: Type 316 SS.
Accuracy: 626: 0.25% FS, 0.20% RSS; 628: 1.0% FS, 0.5% RSS; 626 absolute ranges: 0.5% FS, 0.35% RSS (includes linearity, hysteresis, and repeatability).
Temperature Limits: 0 to 200°F (-18 to 93°C).
Compensated Temperature Limits: 0 to 175°F (-18 to 79°C).
Pressure Limits: See chart.
Thermal Effect: 626: ±0.02% FS/°F; 628: ±0.04% FS/°F (includes zero and span).
Power Requirements: 2-wire: 10 to 35 VDC; 3-wire: 13 to 35 VDC or isolated 16 to 33 VAC (reverse polarity protected).
Output Signal: 2-wire: 4 to 20 mA; 3-wire: Field selectable 0 to 5, 1 to 5, 0 to 10, or 2 to 10 VDC.
Zero Adjustment: Push button inside conduit enclosure.
Response Time: 300 msec.
Loop Resistance: Current output: 0 to 1250 Ω (max), Rmax = 50(Vps-10); Voltage output: Minimum load resistance = 5 kΩ.
Current Consumption: 38 mA (max).
Electrical Connections: Removable terminal block; 1/2" female NPT conduit.
Process Connections: 1/4" female or male NPT.
Enclosure Rating: Designed to meet NEMA 4X (IP66) for non-LCD models.
Mounting Orientation: Not position sensitive.
Weight: 10 oz (283 g).
Agency Approvals: CE.

PRESSURE LIMITS		
Range	*Maximum Pressure	Over Pressure
0 to 5 psi	10 psi	50 psi
0 to 15 psi	30 psi	150 psi
0 to 30 psi	60 psi	300 psi
0 to 50 psi	100 psi	300 psi
0 to 100 psi	200 psi	500 psi
0 to 150 psi	300 psi	750 psi
0 to 200 psi	400 psi	1000 psi
0 to 300 psi	600 psi	1500 psi
0 to 500 psi	1000 psi	2500 psi
0 to 600 psi	1200 psi	3000 psi
0 to 1000 psi	2000 psi	5000 psi
0 to 1500 psi	3000 psi	5000 psi
0 to 3000 psi	6000 psi	7500 psi
0 to 5000 psi	7500 psi	10000 psi
0 to 8000 psi	10000 psi	12000 psi

*Pressures exceeding the maximum pressure limit may cause a calibration shift of up to ±3% of full scale.

INSTALLATION

1. Location: Select a location where the temperature of the unit will be between 0 and 175°F (-18 to 79°C). Distance from the receiver is limited only by total loop resistance. The tubing feeding pressure to the instrument can be practically any length required, but long lengths will increase response time slightly.

2. Position: The transmitter is not position sensitive. However, all standard models are originally calibrated with the unit in a position with the pressure connection downward. Although they can be used at other angles, for best accuracy, it is recommended that units be installed in the position calibrated at the factory.

3. Pressure Connection: Use a small amount of plumber’s tape or other suitable sealants to prevent leaks. Be sure the pressure passage inside the port is not blocked.

4. Electrical Connections

Wire Length — The maximum length of wire connecting the transmitter and receiver is a function of wire size and receiver resistance. Wiring should not contribute to more than 10% of the receiver resistance to total loop resistance. For extremely long runs (over 1000 ft or 305 m), choose receivers with higher resistance to minimize the size and cost of connecting leads. Where wiring length is under 100 feet (30.5 m), wire as small as 22 AWG can be used.

CURRENT (4 to 20 mA) OUTPUT OPERATION

An external power supply delivering 10 to 35 VDC with minimum current capability of 40 mA DC (per transmitter) is required to power the control loop. See Figure 1 for connection of the power supply, transmitter, and receiver. The range of appropriate receiver load resistance (R_L) for the DC power supply voltage available is expressed by the formula:

$$R_L \text{ Max} = \frac{V_{ps} - 10}{20 \text{ mA DC}}$$

Shielded cable is recommended for control loop wiring.

Electrical connections to the Series 626/628-CB pressure transmitters are made to the terminal block located inside the housing. Remove the screws and lift off the cover. Lift off the terminal block for wiring. Wire as show in Figure 1 or 2. Use Figure 1 for current output connection. Use Figure 2 for current output with optional LCD display. If ordering pre-wired cable, black wire is negative (-) and red wire is positive (+).

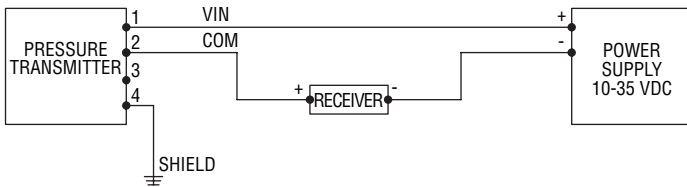

Figure 1: Current Output Connection

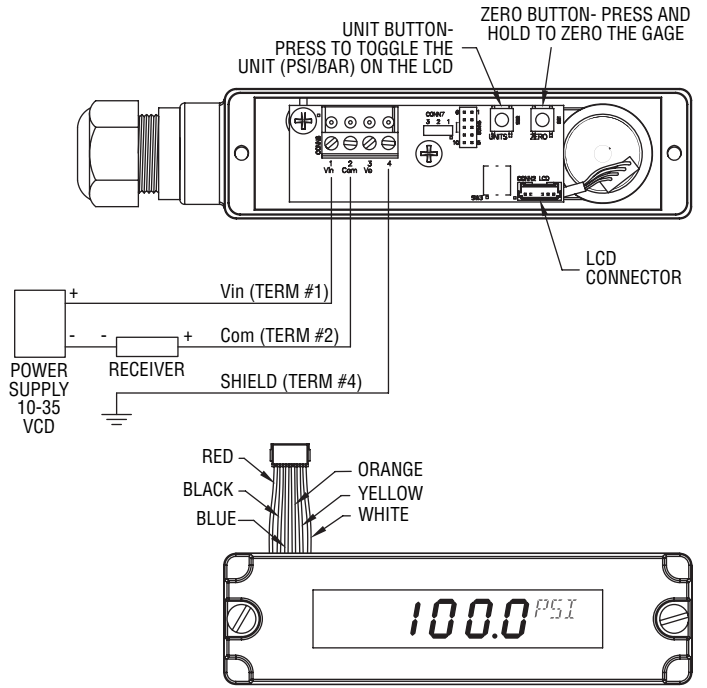

Figure 2: Current Output with Optional LCD

M-12 Pin Connector with Current Output

For the optional M-12 4 pin connector, wire to pins as shown in Figure 3.

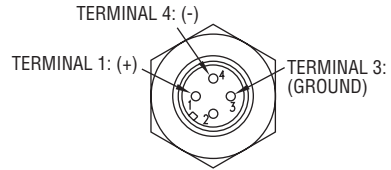

Figure 3: Current Output with Optional M-12 4 Pin Connector

VOLTAGE (0 to 5, 1 to 5, 0 to 10, or 2 to 10 V) OUTPUT OPERATION

To select the voltage output that is going to be used, configure the DIP switches according to the Figure 4 below. Power must be cycled whenever dip switches are changed to select output.

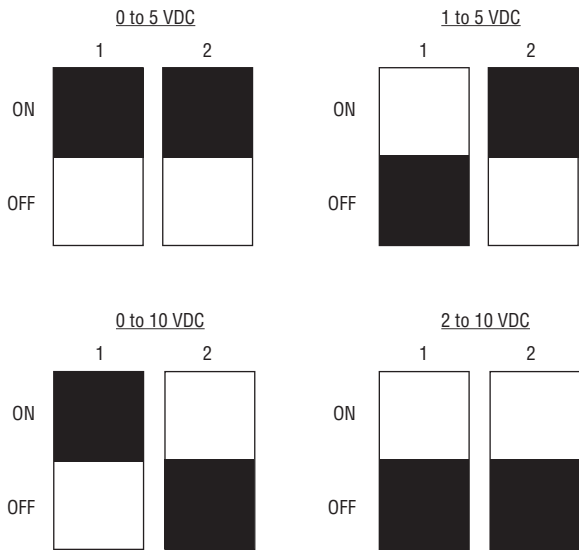

Figure 4: Voltage Output DIP Switch Selection

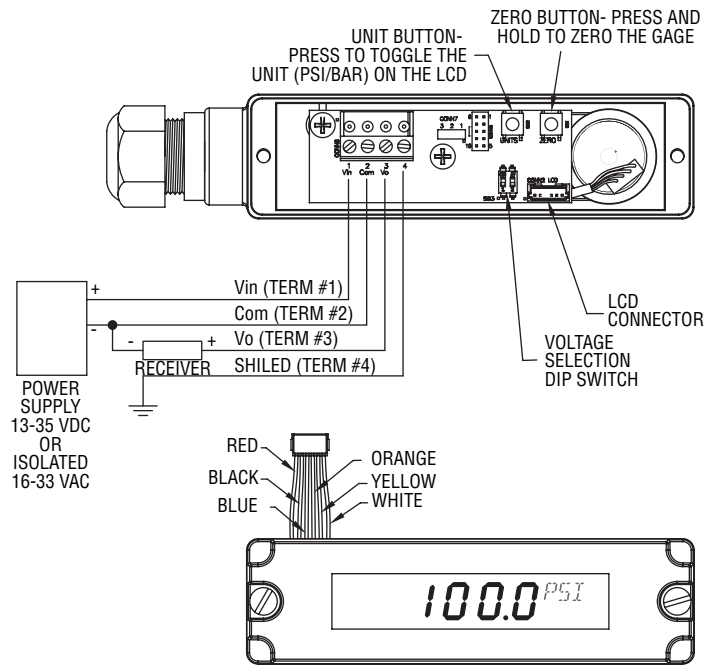

Figure 6: Voltage Output with Optional LCD

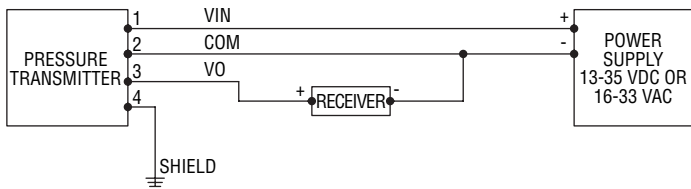

Figure 5: Voltage Output Connection

M-12 4 Pin Connector with Voltage Output

For the optional M-12 4 pin connector, wire to pins as shown in Figure 7.

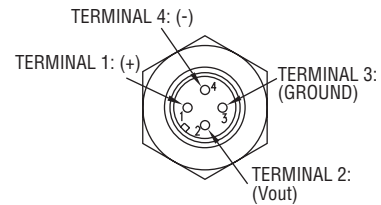

Figure 7: Voltage Output with Optional M-12 4 Pin Connector

MODEL CHART								
Example	626	-02	-CB	-P1	-E2	-S8	-NIST	626-02-CB-P1-E2-S8-NIST
Series	626 628							0.25% full scale accuracy 1.0% full scale accuracy
Range		06 07 08 09 10 11 12 13 14 22 15 16 18 19 26						0 to 5 psi 0 to 15 psi 0 to 30 psi 0 to 50 psi 0 to 100 psi 0 to 150 psi 0 to 200 psi 0 to 300 psi 0 to 500 psi 0 to 600 psi 0 to 1000 psi 0 to 1500 psi 0 to 3000 psi 0 to 5000 psi 0 to 8000 psi
Housing			CB					Conduit box housing
Process Connection				P1 P2 P3 P4				1/4" male NPT 1/4" female NPT 1/4" male BSPT 1/4" female BSPT
Electrical Connection				E1 E2 E3 E5 E9				Cable gland with 3' prewired cable Cable gland with 6' prewired cable Cable gland with 9' prewired cable 1/2" female NPT conduit M-12 4 pin connector (not UL)
Signal Output						S1 S8		4 to 20 mA Selectable 0 to 5, 1 to 5, 0 to 10, or 2 to 10 VDC
Options							AT LCD NIST SPCL	Aluminum tag LCD display NIST traceable calibration certificate Special cleaning for oxygen use
*Pressures exceeding the working pressure limit may cause a calibration shift of up to ±3% of full scale.								

MAINTENANCE/REPAIR

Upon final installation of the Series 626/628-CB Industrial Pressure Transmitter, no routine maintenance is required. The Series 626/628-CB is not field serviceable and is not possible to repair the unit. Field repair should not be attempted and may void warranty.

WARRANTY/RETURN

Refer to "Terms and Conditions of Sale" in our catalog and on our website. Contact customer service to receive a Return Goods Authorization number before shipping the product back for repair. Be sure to include a brief description of the problem plus any additional application notes.