

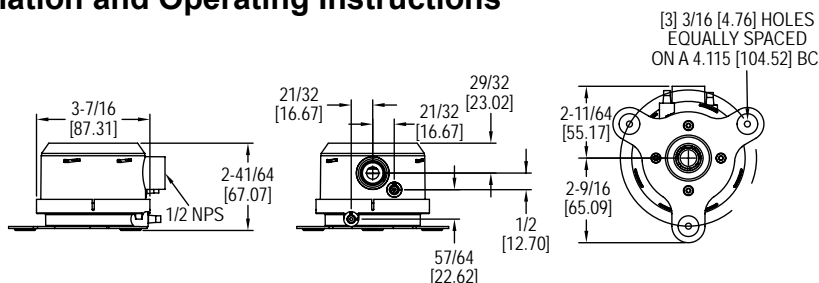

## Series MS Magnesense® Differential Pressure Transmitter

### Specifications - Installation and Operating Instructions



Wall mount bracket

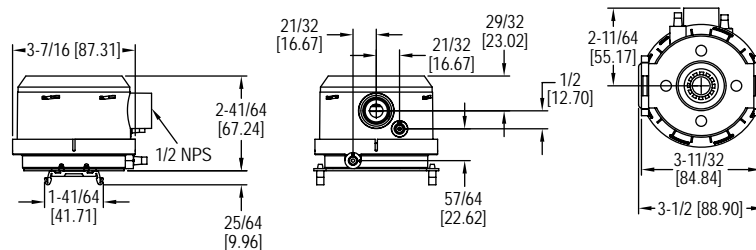

DIN mount bracket

The **Series MS Magnesense® Differential Pressure Transmitter** is an extremely versatile transmitter for monitoring pressure and air velocity. This compact package is loaded with features such as: field selectable English or metric ranges, field upgradeable LCD display and the ability to select a square root output for use with pitot tubes and other similar flow sensors. Also, a single digital push button simultaneously calibrates both zero and span reducing installation and setup time. These features along with exceptional long term performance enables the Magnesense® to be the solution for a myriad of pressure and air flow applications.

#### INSTALLATION

##### Mounting:

The transmitter should be mounted on a vertical surface with the connections directed down to prevent moisture from entering either the pressure ports or the electrical cable entry. Mount the transmitter using #8 x 1/2" pan head sheet metal screws in the mounting flanges. Do not over tighten.

##### Electrical Connection:

##### 2-wire Operation:

**CAUTION** DO NOT EXCEED SPECIFIED SUPPLY VOLTAGE RATINGS. PERMANENT DAMAGE NOT COVERED BY WARRANTY WILL RESULT. 2-WIRE UNITS ARE NOT DESIGNED FOR AC VOLTAGE OPERATION.

#### SPECIFICATIONS

**Service:** Air and non-combustible, compatible gases.

**Wetted Materials:** Consult factory.

**Accuracy:** ±1% @ standard conditions.

**Stability:** ±1% FS/ year.

**Temperature Limits:** 0 to 150°F (-18 to 66°C).

**Pressure Limits:** 1 psi (6.89 kPa) max, operation; 10 psi (68.9 kPa), burst.

**Power Requirements:** 2-wire, 10-35 VDC; 3-wire, 17-36 VDC or isolated 21.6-33 VAC.

**Output Signals:** 2-wire, 4-20 mA; 3-wire, 0-10 V or 0-5 V.

**Response Time:** 300 msec.

**Pressure Calibration:** One digital push button set both zero and span simultaneously.

**Loop Resistance:** Current output: 0 to 1250 Ω max.; Voltage output: Min. load resistance 1 k Ω.

**Current Consumption:** 40 mA max.

**Display (Optional):** 4 digit LCD.

**Electrical Connections:** 4-20 mA units: 2-wire: European style terminal block for 16 to 26 AWG; 0-10 V units: 3-wire: European style terminal block 16 to 22 AWG.

**Electrical Entry:** 1/2" NPS thread. Accessory: A-151 cable gland for 5 to 10 mm diameter cable.

**Process Connections:** 3/16" (5 mm) ID tubing. Max. OD 9 mm.

**Enclosure Rating:** NEMA 4X (IP66).

**Mounting Orientation:** Insensitive to mounting orientation.

**Weight:** 8.0 oz (230 g).

**Agency Approval:** CE.

**The following standards were used for CE approval:** CENELEC EN 61000-4-2: 2001, CENELEC EN 61000-4-3: 2002, CENELEC EN 61000-4-4: 1995, CENELEC EN 61000-4-5: 2001, CENELEC EN 61000-4-6: 2003, CENELEC EN 61000-4-8: 2001, CENELEC EN 55011: 2003, CENELEC EN 61326: 2002, 89/336/EED EMC Directive.

**Electrical Connection:**

**2-wire Operation, Continued:**

The connections to the transmitter are made through a two circuit European style terminal block CONN6 located at the bottom of the main PCB board. Polarity is indicated by + and - signs on the PCB board. Do not connect to the (V) terminal.

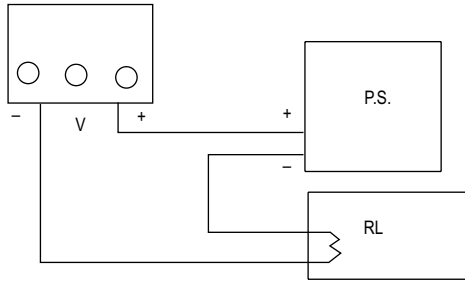

**Figure 1**

An external power supply delivering 10-35 VDC with a minimum current capability of 40 milliamps must be used to power the control loop in which the Magnesense® transmitter is connected. Refer to Figure 1 for connection of the power supply, transmitter and receiver. The range of appropriate receiver load resistances (RL) for the power supply voltage available is given by the formula and graph in Figure 2. Shielded two wire cable is recommended for control loop wiring and the negative side of the loop may be grounded if desired. Note also that the receiver may be connected in either the negative or positive side of the loop, whichever is most convenient. Should polarity of the transmitter or receiver be inadvertently reversed, the loop will not function properly but no damage will be done to the transmitter.

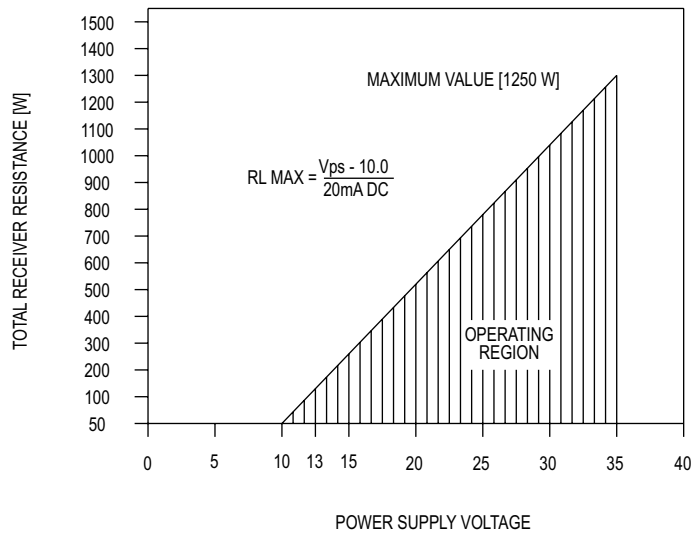

**Figure 2**

The maximum length of connecting wire between the transmitter and the receiver is a function of wire size and receiver resistance. That portion of the total current loop resistance represented by the resistance of the connecting wires themselves should not exceed 10% of the receiver resistance. For extremely long runs (over 1,000 feet), it is desirable to select receivers with higher resistances in order to keep the size and cost of the connecting leads as low as possible. In installations where the connecting run is no more than 100 feet, connecting lead wire as small as No. 22 Ga. can be used.

**3-wire Operation:**

**CAUTION** DO NOT EXCEED SPECIFIED SUPPLY VOLTAGE RATINGS. PERMANENT DAMAGE NOT COVERED BY WARRANTY WILL RESULT.

The connections to the transmitter are made through a three circuit European style terminal block. Connect the power and signal leads to the corresponding terminals as shown in Figure 3. When using a DC supply, the positive of the supply should be connected to (+) and the negative connected to (-). Connecting the leads in reverse will not damage the device but it will not operate. The DC supply should be capable of providing 20 mA or more of current per Magnesense® transmitter.

When using an isolated AC supply, either leads of the supply may be connected to (-) and (+). The input diode of the device half wave rectifies and filters the applied AC voltage. A small DC current of less than 20 mA is thus drawn through the transformer. The transformer used for the AC supply must be capable of handling this small DC current. Use a UL 1584 Class 2 rated transformer rated between 24 V and 30 VAC, 40 VA or larger, 50/60 Hz. UL 1584 Class 2 rated transformers are limited to 30 VAC maximum under any conditions at nominal line. The AC input voltage to the device is thus limited to a minimum of 21.6 at low line (24 V-10%) and 33 V at high line (30 V+10%).

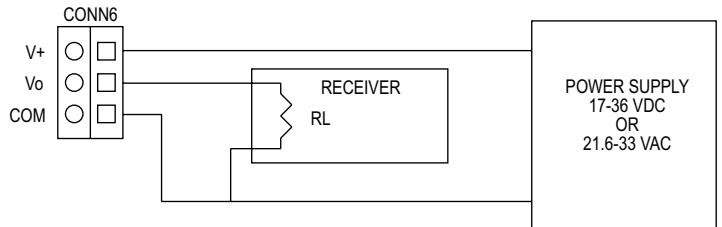

**Figure 3**

The output of (V) is 0-5 VDC or 10 VDC depending on model. As much as 10 mA may be drawn from (V) without affecting accuracy. This limits the minimum load RL connected to Vo to 1 KΩ or higher. Remember to keep the wiring resistance between the output and the receiver RL low compared to value of RL. While the voltage at the terminals remains unchanged with a 10 mA current flow, resistive losses in the wiring do cause errors in the voltage delivered to RL. For a 1% accurate gauge, a good rule of thumb would be to keep the resist 0.1% of the value of RL. This will keep the error caused by current flow below 0.1%.

To minimize noise in the signal use shielded cable. The common line may also be grounded.

**Pressure Connections**

Two integral tubing connectors are provided. They are designed to fit 3/16" (5 mm) ID tubing. Connect the high pressure to the High side as shown in Figure 4. Be sure the pressure ratings of the tubing exceed that of the operating ranges.

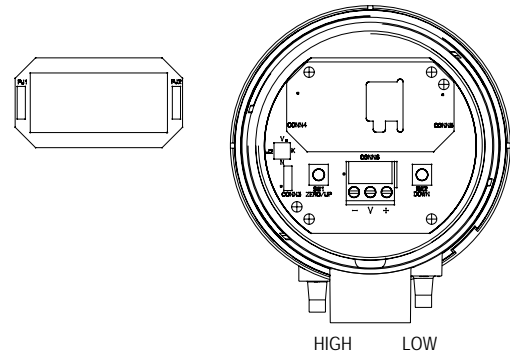

**Figure 4**

**MAINTENANCE**

Annual recalibration is suggested. No lubrication or other periodic servicing is required. Keep exterior and cover clean. Occasionally disconnect pressure lines to vent both sides of gauge to atmosphere and re-zero. Do not use solvent to clean transmitter. Use only plastic compatible cleaners or water.

The Series MS is not field serviceable and should be returned if repair is needed (field repair should not be attempted and may void warranty). Be sure to include a brief description of the problem plus any relevant application notes. Contact customer service to receive a return goods authorization number before shipping.



This symbol indicates waste electrical products should not be disposed of with household waste. Please recycle where facilities exist. Check with your Local Authority or retailer for recycling advice.