

Supplementary Components

Displays

SITRANS RD150

Overview



The SITRANS RD150 is a remote display for 4 to 20 mA and HART devices.

Benefits

- Ease of use through 4 button menu driven display
- Backlit display
- HART communications
- Flexible mounting options
- Plastic, stainless steel or aluminum housings up to IP68
- Full configuration of connected sensors with optional USB Communicator and PC
- Support for multiple HART sensors with HART Multi-drop

Application

The versatile SITRANS RD150 can be installed remotely from your instrument, providing 4/20 mA or multiple HART variable readings in a safe and convenient location.

Easy to use, 4 button, menu driven, display for configuration of HART instruments via standard HART commands and full configuration of connected instruments via USB and computer.

- Key Applications: remotely displays process variables in level, flow, pressure, temperature, and weighing applications, in a 4 to 20 mA HART loop.

Technical specifications

Mode of operation	
Measuring principle	Analog to digital conversion
Measuring range	3.5 ... 22.5 mA
Measuring points	HART multi-drop support
Accuracy	
	± 0.1 % of 20 mA
Rated operating conditions	
Without display and adjustment module	-40 ... +80 °C (-40 ... +176 °F)
With display and adjustment module	-20 ... +70 °C (-4 ... +158 °F)
Design	
Weight	
• Plastic housing	0.35 kg (0.772 lb)
• Aluminum housing	0.7 kg (1.543 lb)
• Stainless steel housing	2.0 kg (4.409 lb)
Material (enclosure)	
• Plastic housing	Plastic PBT (Polyester)
• Aluminum housing	Aluminum die-casting AISi10Mg, powder-coated (basis: Polyester)
• Stainless steel housing	316L precision casting, blasted
Degree of protection	
• Plastic housing	IEC 60529 IP 66/IP 67, NEMA Type 4X
• Housing for panel mounting (mounted)	IEC 60529 IP 40, NEMA Type 1
• Aluminum/stainless steel housing	IEC 60529 IP66/IP68 (0.2 bar), NEMA Type 6P
Power supply	
External loop power supply	35 V DC max.
Display	
Number of digits	5
Digit size	7 x 13 mm (0.28 x 0.51 inch)
Certificates and approvals	
	See the online PIA configuration tool for details.
Options	
Mounting	<ul style="list-style-type: none"> • Panel Mounting • Carrier rail mounting • Pipe mounting

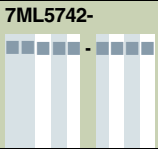
Selection and Ordering data	Article No.
SITRANS RD150 display Remote digital display with configuration for process instruments. HART or 4 to 20 mA loop display, metal and plastic field mount enclosures. ↗ Click on the Article No. for the online configuration in the PIA Life Cycle Portal.	7ML5742- 
Approvals For Ex-free area ATEX II 1G, 2G Ex ia IIC T6 Ga, Gb ⁴⁾ ATEX II 2G Ex db IIC T6 Gb ⁹⁾¹⁰⁾ IEC Ex ia IIC T6 Ga, Gb ⁴⁾ IEC Ex db IIC T6 Gb ⁹⁾¹⁰⁾ cCSA _{US} (IS) Class I, Div. 1, Groups A, B, C, D ¹²⁾ cCSA _{US} (XP) Class I, Div. 1, Groups A, B, C, D ⁹⁾¹¹⁾	0 A 0 C 0 F 0 J 0 M 0 N 0 R
Electronics Two-wire 4 ... 20 mA/HART	A
Housing Plastic ¹⁾⁴⁾⁶⁾ Aluminum ²⁾⁴⁾⁷⁾ Stainless steel (precision casting) ²⁾⁴⁾⁷⁾ For panel mounting (72 x 72 mm) ³⁾⁵⁾⁸⁾	0 1 2 3
Housing protection IP66/IP67 NEMA 4X IP66/IP68 NEMA 6P (0.2 bar) IP40 NEMA 2 IP40 Type 1	0 1 2 3
Cable entry M20 x 1.5/Cable gland PA black (ø5 ... 9 mm), standard M20 x 1.5/Cable gland brass nickel plated (ø6 ... 12 mm) M20 x 1.5/Blind plug M20 x 1.5/Threaded fitting brass nickel-plated; for shielded cable (ø9 ... 13 mm) ½" NPT/Blind plug ½" NPT/Cable gland PA black (ø5 ... 9 mm) ½" NPT/Threaded fitting brass nickel-plated (ø6 ... 12 mm) ½" NPT/Threaded fitting brass nickel-plated; for shielded cable (ø9 ... 13 mm) Without	0 1 2 3 4 5 6 7 8
Display Without Mounted	A B
Mounting For wall mounting with aluminum or stainless steel housing For carrier rail and wall mounting with plastic housing For carrier rail with aluminum or stainless steel housing For tube mounting (29 ... 60 mm) incl. mounting material For panel mounting	A B C D E
Certificates None 3.1 Certificate/Instrument with test data Quality and Test plan	0 1 2
Operating Instructions All literature is available to download for free, in a range of languages, at http://www.siemens.com/processinstrumentation/documentation	
Accessories USB communicator	A5E35192015

- 6) Available only with Carrier rail and Tube mount Mounting options.
- 7) Available only with Wall mount, Carrier rail with aluminum or stainless steel housing, and Tube mount Mounting options.
- 8) Available only with Panel mounting option.
- 9) Available only with Housing options 1 and 2.
- 10) Available only with Cable entry options 2, 3, 4, and 7.
- 11) Available only with Cable entry options 2, 3, 4, 6, and 7.
- 12) Not available with Cable entry option 1.

- 1) Available only with Housing protection option 0.
- 2) Available only with Housing protection option 1.
- 3) Available only with Housing protection option 2.
- 4) Available only with Cable entry options 0, 2, 4, and 5.
- 5) Available only without Cable entry option 8.

Supplementary Components

Displays

SITRANS RD150

Dimensional drawings

SITRANS RD150, aluminum/stainless steel housing

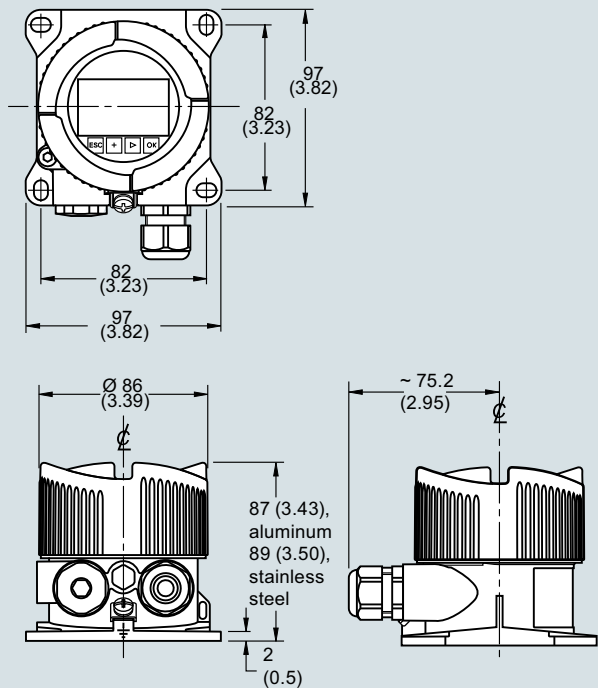

SITRANS RD150, plastic housing

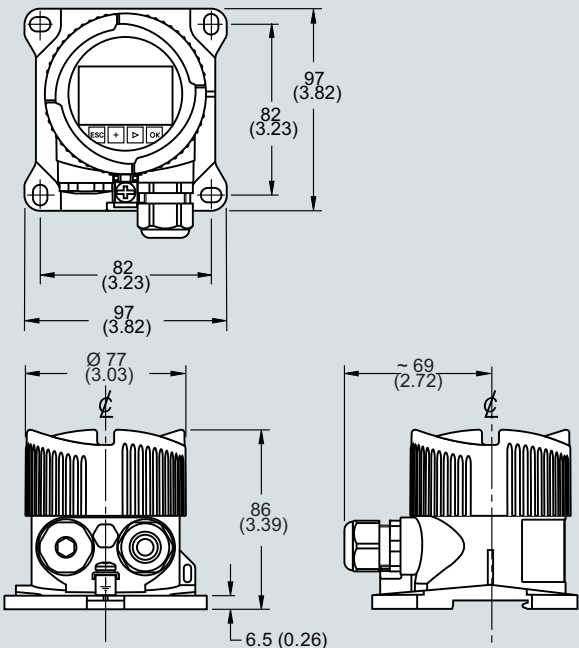

SITRANS RD150, dimensions mm (inch)

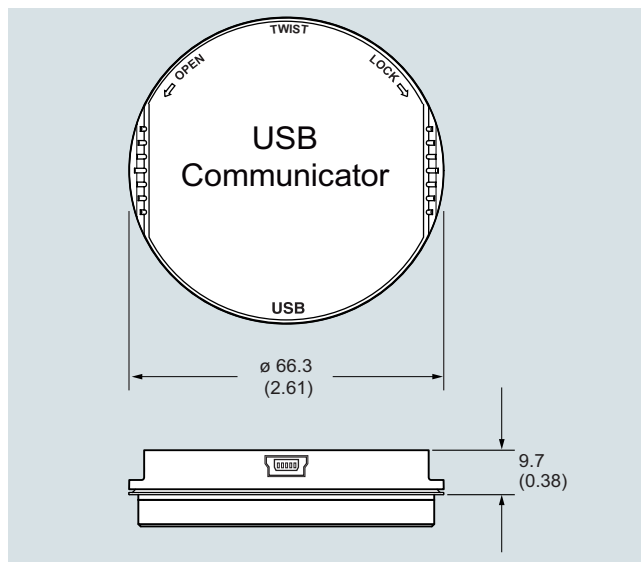

USB Communicator, dimensions in mm (inch)

Circuit diagram

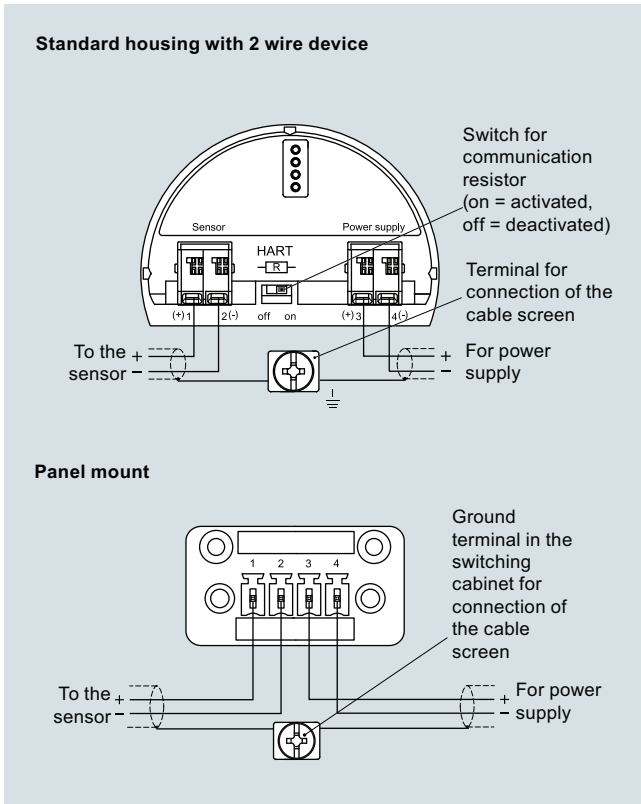

SITRANS RD150 connections