

Features

- Specially designed for reverse jet-type dust collector systems
- High flow Cv(s) to 140 for effective bag cleaning
- High cycle life
- Fast opening/closing

Construction

Valve Parts in Contact with Fluids	
Body	Aluminum
Seals	NBR
Diaphragm	NBR, HYT or CR as noted
Discs	NBR or PA, as noted



Electrical

Standard Coil and Class of Insulation	Watt Rating and Power Consumption			Spare Coil Part Number	
	AC			General Purpose	Explosionproof
	Watts	VA Holding	VA Inrush	AC	AC
F	6.1	16	30	238210	238214
F	10.1	25	50	238610	238614
F	17.1	40	70	238610	238614

Standard Voltages: 24, 120, 240, 480 volts AC, 60 Hz (or 110, 220 volts AC, 50 Hz), Consult factory for DC voltage. Other voltages available when required.

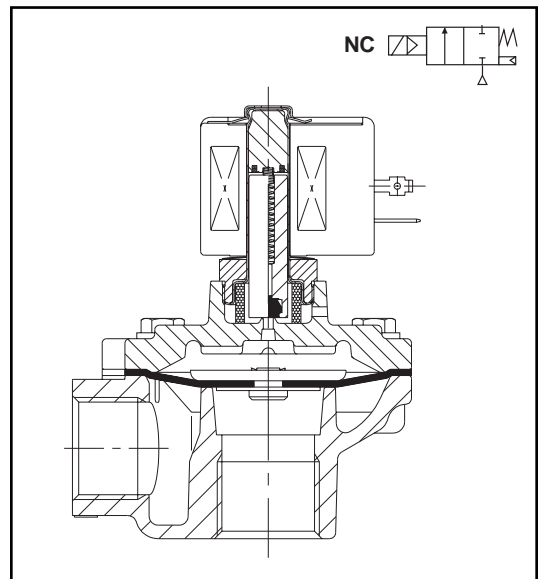

Solenoid Enclosures

Standard: Watertight, Types 1, 2, 3, 3S, 4, and 4X.

Optional: Explosionproof and Watertight, Types 3, 3S, 4, 4X, 6, 6P, 7, and 9. (To order, add prefix "EF" to catalog number.)

See *Optional Features Section* for other available options. Consult your local ASCO office for details on accessories.

Nominal Temp. Ranges

Ambient: AC constructions: 0°F to 185°F (-18°C to 85°C); 150°F (66°C) for valves with HYT diaphragms. Consult local sales office for DC constructions.

Fluids: 0°F to 185°F (-18°C to 85°C), except as noted. For temperatures to 300°F (149°C), specify FPM, suffix "V" (except where noted).

Refer to *Engineering Section* for details.

SPECIAL SERVICE VALVES

Specifications (English units)

Pipe Size (in)	Orifice Size (in)	Cv Flow Factor	Min. Operating Pressure Differential (psi) ①	Max. Operating Pressure Differential (psi) ①	Integral Pilot		Remote Pilot Construction (Minimum Pilot Valve Orifice Size = 1/8")	Const. Ref.	Watt Rating/ Class of Coil Insulation AC	Rebuild Kit AC Valves Kit No.	Diaphragm Only 10 Pack "Zip" Kit Kit No.
					Catalog Number	Catalog Number					
3/4	3/4	10.5	5	125	-	-	8353C033 ③	1	-	96875	238864
3/4 ①	3/4	10.5	5	125	-	-	8353C030 ③	1	-	96875	238864
3/4 ②	3/4	10.5	5	125	-	-	8353C004 ③	1	-	96875	238864
1	1 1/8	20	5	125	-	-	8353C035 ④	1	-	200262	238866
1	1 1/8	20	5	125	8353G041 ④	-	-	4	6.1/F	316563	238866
1	1 5/8	18	15	125	8353G006 ⑤⑥	-	-	3	17.1/F	300144	-
1 1/4	1 5/8	20	15	125	8353G005 ⑤⑥	-	-	3	17.1/F	300144	-
1 1/2	1 1/2	35	15	125	8353G001 ⑤⑥	-	-	3	17.1/F	300144	-
1 1/2	2	53	10	125	-	-	8353H038 ④	2	-	276886	238870
1 1/2	2	53	5	125	8353J039 ④	-	-	5	10.1/F	322108	238870
1 1/2	2	48	5	125	8353G061 ⑨	-	-	5	10.1/F	316297	-
1 1/2	2	48	10	125	-	-	8353A062 ⑨	2	-	276884	-
2	2	60	15	125	8353G002 ⑤⑥	-	-	3	17.1/F	300145	-
2	2	76	5	125	-	-	8353 048 ⑥⑦	2	-	256802	256797
2	2	76	5	125	8353G050 ⑥	-	-	5	10.1/F	316029	256797
2 1/2	3	82	15	125	8353G007 ⑤	-	-	6	10.1/F	176878	-
3	3	140	15	125	8353G008 ⑤	-	-	6	10.1/F	176878	-

① Supplied with internal slip fit connection on outlet.
 ② Extended ends for Dresser connections.
 ③ NBR diaphragm.
 ④ HYT diaphragm max. fluid temp. 150°F.
 For higher temperature, consult factory.
 ⑤ CR diaphragm/PA disc.
 ⑥ CR diaphragm.
 ⑦ Minimum pilot orifice size 7/32".
 ⑧ Consult factory for remote piloted construction.
 ⑨ NBR diaphragm, PA disc, long-life construction. Maximum fluid temp. 185°F.
 ⑩ Contact local sales office for DC pressure requirements.

Specifications (Metric units)

Pipe Size (in)	Orifice Size (mm)	Kv Flow Factor (m³/h)	Min. Operating Pressure Differential (bar) ①	Max. Operating Pressure Differential (bar) ①	Integral Pilot		Remote Pilot Construction (Minimum Pilot Valve Orifice Size = 1/8")	Const. Ref.	Watt Rating/ Class of Coil Insulation AC	Rebuild Kit AC Valves Kit No.	Diaphragm Only 10 Pack "Zip" Kit Kit No.
					Catalog Number	Catalog Number					
3/4	19	9.0	0.3	8.6	-	-	8353C033 ③	1	-	96875	238864
3/4 ①	19	9.0	0.3	8.6	-	-	8353C030 ③	1	-	96875	238864
3/4 ②	19	9.0	0.3	8.6	-	-	8353C004 ③	1	-	96875	238864
1	29	17.1	0.3	8.6	-	-	8353C035 ④	1	-	200262	238866
1	29	17.1	0.3	8.6	8353G041 ④	-	-	4	6.1/F	316563	238866
1	41	15.4	1.0	8.6	8353G006 ⑤⑥	-	-	3	17.1/F	300144	-
1 1/4	41	17.1	1.0	8.6	8353G005 ⑤⑥	-	-	3	17.1/F	300144	-
1 1/2	38	30.0	1.0	8.6	8353G001 ⑤⑥	-	-	3	17.1/F	300144	-
1 1/2	51	45.4	0.7	8.6	-	-	8353H038 ④	2	-	276886	238870
1 1/2	51	45.4	0.3	8.6	8353J039 ④	-	-	5	10.1/F	322108	238870
1 1/2	51	41.1	0.3	8.6	8353G061 ⑨	-	-	5	10.1/F	316297	-
1 1/2	51	41.1	0.7	8.6	-	-	8353A062 ⑨	2	-	276884	-
2	51	51.4	1.0	8.6	8353G002 ⑤⑥	-	-	3	17.1/F	300145	-
2	51	65.1	0.3	8.6	-	-	8353 048 ⑥⑦	2	-	256802	256797
2	51	65.1	0.3	8.6	8353G050 ⑥	-	-	5	10.1/F	316029	256797
2 1/2	76	70.3	1.0	8.6	8353G007 ⑤	-	-	6	10.1/F	176878	-
3	76	120.0	1.0	8.6	8353G008 ⑤	-	-	6	10.1/F	176878	-

SPECIAL SERVICE VALVES

Dimensions inches (mm)

Cat. No.	"G"		H	L	P	Bonnet Bolts	T	W
8353C004	Extended End	in	7.94	3.69	2.16	5.00	5.16	3.44
		mm	201.6	93.7	54.8	127.0	131.0	87.3
8353C030	3/4 NPT (Inlet)	in	3.44	1.69	2.19	5.00	3.47	3.44
		mm	87.3	42.9	55.6	127.0	88.1	87.3
	3/4 Socket (Outlet)	in	3.44	1.69	2.19	5.00	3.47	3.44
		mm	87.3	42.9	55.6	127.0	88.1	87.3
8353C033	3/4 NPT	in	3.44	1.69	2.19	5.00	3.47	3.44
		mm	87.3	42.9	55.6	127.0	88.1	87.3
8353C035	1 NPT	in	2.53	2.03	1.69	4.00	3.50	2.94
		mm	64.3	51.6	42.9	101.6	88.9	74.6

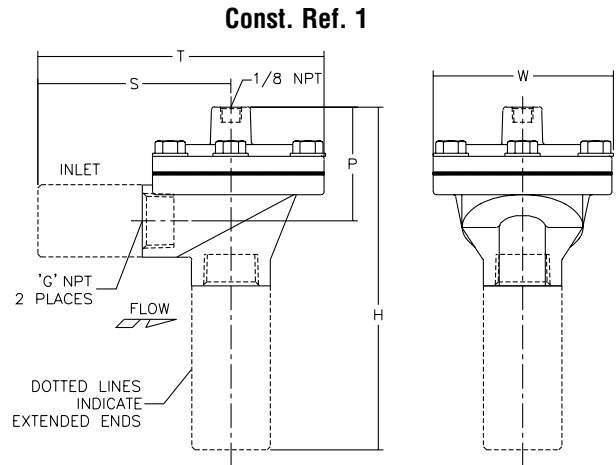

Cat. No.	"E" NPT	"G" NPT	H	L	P	"R" NPT	S	T	W	X	
8353H038	3/8	1 1/2	in	4.63	5.16	3.44	1/8	2.78	1.61	5.38	0.44
			mm	117.5	131.0	87.3		70.6	40.9	136.5	11.1
8353A062	3/8	1 1/2	in	5.16	5.16	3.44	1/8	2.78	1.61	5.38	0.44
			mm	131.0	131.0	87.3		70.6	40.9	136.5	11.1
8353 048	3/4	2	in	6.47	6.63	4.69	1/4	3.75	2.56	6.50	-
			mm	164.3	168.3	119.1		95.3	65.1	165.1	-

Cat. No.	"G" NPT	H	L	P	S	T	W	
8353G001	1 1/2	in	7.72	5.00	6.47	1.78	5.13	5.38
		mm	196.1	127.0	164.3	45.2	130.2	136.5
8353G002	2	in	8.34	6.09	6.84	1.78	5.56	6.34
		mm	211.9	154.8	173.8	45.2	141.3	161.1
8353G005	1 1/4	in	7.72	5.00	6.47	1.78	5.13	5.38
		mm	196.1	127.0	164.3	45.2	130.2	136.5
8353G006	1	in	7.72	5.00	6.41	1.78	5.13	5.38
		mm	196.1	127.0	162.7	45.2	130.2	136.5

Const. Ref. 2

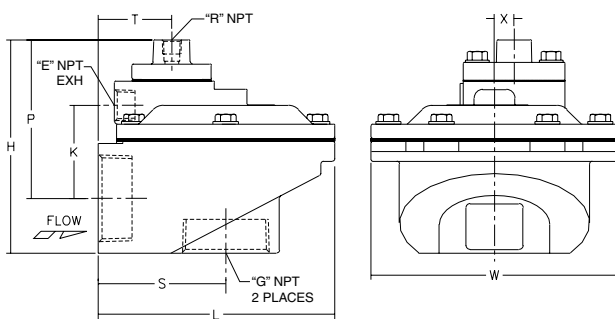

Const. Ref. 3

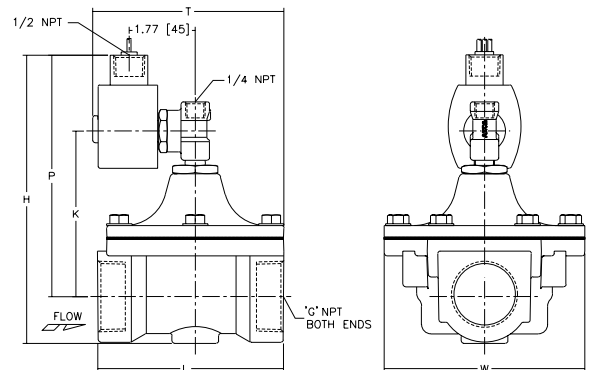

Dimensions inches (mm)

Const. Ref. 4

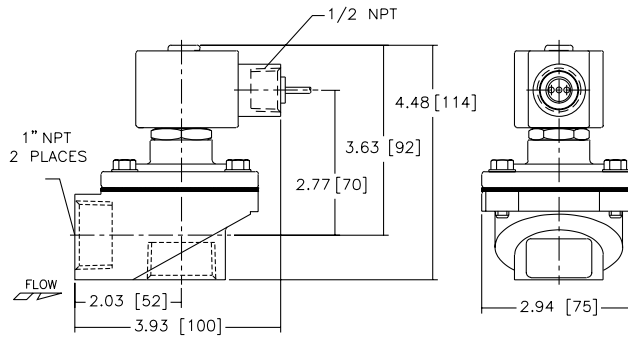

Const. Ref. 5

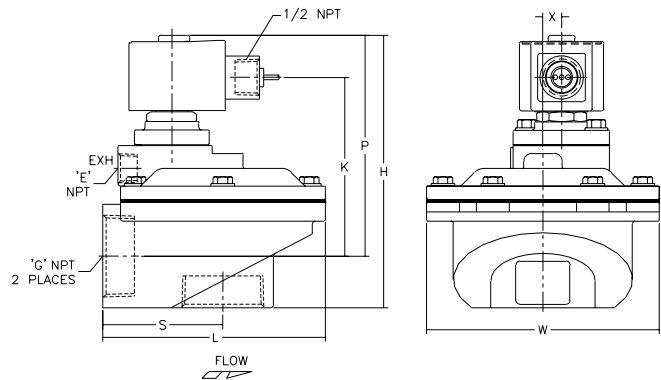

Cat. No.	"E" NPT	"G" NPT	H		L		P		S		T		W		X		
			in	mm	in	mm	in	mm	in	mm	in	mm	in	mm	in	mm	
8353J039	3/8	1 1/2	in	6.28	5.16	5.08	2.78	1.61	5.38	0.44							
			mm	159.5	131.0	129.0	70.6	40.9	136.5	11.1							
8353G061	3/8	1 1/2	in	6.28	5.16	5.08	2.78	1.61	5.38	0.44							
			mm	159.5	131.0	129.0	70.6	40.9	136.5	11.1							
8353G050	3/4	2	in	8.25	6.63	6.47	3.75	2.56	6.50	-							
			mm	209.6	168.3	164.3	95.3	65.1	165.1	-							

Const. Ref. 6

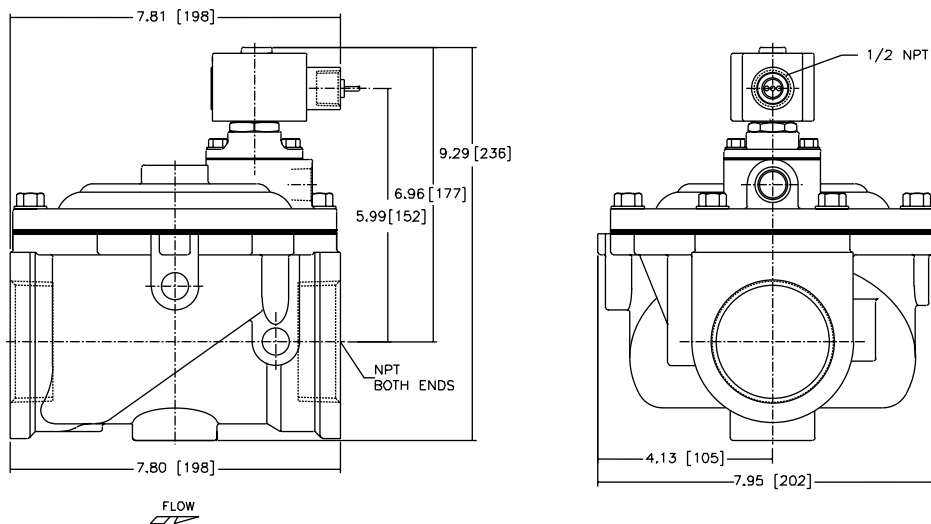

SPECIAL SERVICE VALVES