

## Features

- Reliable, proven design with high flows
- Small poppet valves for tight shutoff
- Wide range of elastomers for specialty service
- Mountable in any position
- Brass and stainless steel constructions

## Construction

Valve Parts in Contact with Fluids		
Body	Brass	303/304 Stainless Steel
Seals and Discs	NBR or Cast UR	
Core Tube	305 Stainless Steel	
Core and Plugnut	430F Stainless Steel	
Springs	302 Stainless Steel	
Shading Coil	Copper	Silver
Stem	PA	

## Electrical

Watt Rating and Power Consumption				Spare Coil Part No.			
DC Watts	AC			General Purpose		Explosionproof	
	Watts	VA Holding	VA Inrush	AC	DC	AC	DC
11.6	10.1	25	50	238610	238910	238614	238914
22.6	17.1	40	70	238810	238910	238814	238914

**Standard Voltages:** 24, 120, 240, 480 volts AC, 60 Hz (or 110, 220 volts AC, 50 Hz).  
 6, 12, 24, 120, 240 volts DC. Must be specified when ordering.  
 Other voltages available when required.

## Solenoid Enclosures

**Standard:** Watertight, Types 1, 2, 3, 3S, 4, and 4X.

**Optional:** Explosionproof and Watertight, Types 3, 3S, 4, 4X, 6, 6P, 7, and 9.  
 (To order, add prefix "EF" to catalog number)

See *Optional Features Section* for other available options.

## Options

Mounting bracket (suffix MB)

High Vacuum service (suffix VH; see *Vacuum Section* for more details.)

Oxygen service (suffix N)

Silicone Free (suffix SF)

**Elastomers:** FKM (suffix V), Ethylene Propylene (suffix E),  
 CR (suffix J), PTFE\* (suffix T), Low Temp. NBR\*\* (suffix A)

**Note:** \*PTFE reduces pressure rating by 25% (i.e. 750 psi reduced to 560 psi)

\*\*For Low Temp. NBR, fluid temperature range is -40°F to 167°F

Refer to *Engineering Section* for fluid and temperature compatibility.

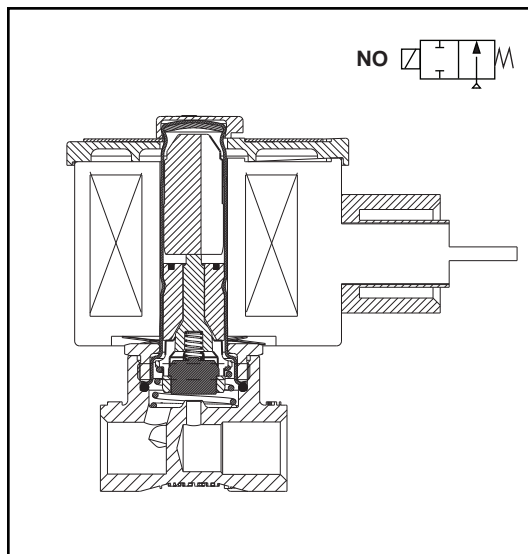
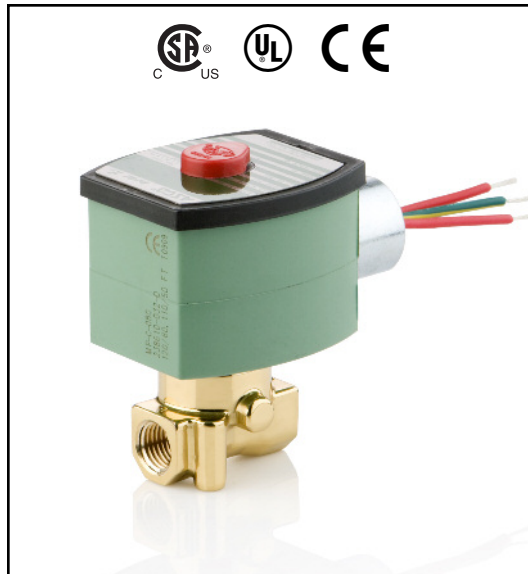

## Nominal Ambient Temp. Ranges

AC: -13°F to 131°F (-25°C to 55°C)

DC: -13°F to 131°F (-25°C to 55°C)

**Optional:** For AC Class H coil option with 10.1 W coil, the max. ambient temperature is 140°F (60°C) (with or without prefix EF)

**Note:** Max. ambient for explosionproof (EF) is 125°F (52°C) for AC, 131°F (55°C) for DC.

Refer to *Engineering Section* for details.

## Approvals

CSA certified. UL listed, as indicated.

Meets applicable CE directives.

Refer to *Engineering Section* for details.

ATEX/IECEx certified with prefix "EV" as listed. Refer to *Optional Features Electrical Section* for details.

**Specifications (English units)**

Pipe Size (in)	Orifice Size (mm)	Cv Flow	Min Press	Operating Pressure Differential (psi)						Max. Fluid Temp °F		Catalog Number		Const. Ref	UL Listing	Watt Rating/ Class of Coil Insulation	
				Max AC@131°F			Max DC@131°F			AC	DC	Brass	Stainless Steel			AC	DC
				Air-Inert Gas	Water	Lt. Oil @ 300 SSU	Air-Inert Gas	Water	Lt. Oil @ 300 SSU								
1/8	3/64	0.06	0	1500	1375	1125	700	600	510	140	140	8262H154 ①	-	1	●	17.1/H	22.6/H
1/8	3/64	0.06	0	1650	1375	1125	700	600	510	140	140	-	8262H167 ①	1	●	17.1/H	22.6/H
1/8	3/64	0.06	0	1150	900	800	640	490	325	140	140	8262H155 ①	8262H168 ①	1	●	10.1/F	11.6/H
1/8	3/64	0.06	0	750	750	750	650	560	400	180	180	8262H156	8262H169	1	●	10.1/F	11.6/H
1/8	3/32	0.21	0	350	305	275	230	190	155	167	180	8262H157	8262H172	1	●	17.1/H	22.6/H
1/8	3/32	0.21	0	275	230	180	160	135	95	180	180	8262H128	8262H236	1	●	10.1/F	11.6/H
1/8	1/8	0.35	0	210	195	175	135	110	100	167	180	8262H158	8262H228	1	●	17.1/H	22.6/H
1/8	1/8	0.35	0	160	145	125	100	100	70	180	180	8262H129	8262H237	1	●	10.1/F	11.6/H
1/4	3/64	0.06	0	1500	1375	1125	940	600	510	140	140	8262H159 ①	-	2	●	17.1/H	22.6/H
1/4	3/64	0.06	0	1650	1375	1125	940	600	510	140	140	-	8262H198 ①	2	●	17.1/H	22.6/H
1/4	3/64	0.06	0	1150	900	800	640	490	325	140	140	8262H161 ①	8262H199 ①	2	●	10.1/F	11.6/H
1/4	3/64	0.06	0	750	750	750	650	560	400	180	180	8262H260	8262H130	2	●	10.1/F	11.6/H
1/4	3/32	0.21	0	350	305	275	230	190	155	167	180	8262H162	8262H205	2	●	17.1/H	22.6/H
1/4	3/32	0.21	0	275	230	180	160	135	95	180	180	8262H261	8262H134	2	●	10.1/F	11.6/H
1/4	1/8	0.35	0	210	195	175	135	110	100	167	180	8262H163	8262H219	2	●	17.1/H	22.6/H
1/4	1/8	0.35	0	160	145	125	100	100	70	180	180	8262H262	8262H138	2	●	10.1/F	11.6/H
1/4	5/32	0.54	0	120	110	105	75	65	55	167	180	8262H164	8262H223	2	●	17.1/H	22.6/H
1/4	5/32	0.54	0	90	90	70	60	55	45	180	180	8262H263	8262H142	2	●	10.1/F	11.6/H
1/4	7/32	0.83	0	60	55	55	35	35	30	167	180	8262H165	8262H224	2	●	17.1/H	22.6/H
1/4	7/32	0.83	0	45	45	40	30	25	25	180	180	8262H264 ②	8262H148	2	●	10.1/F	11.6/H
1/4	9/32	0.96	0	38	38	38	25	25	25	167	180	8262H166	8262H225	2	●	17.1/H	22.6/H
1/4	9/32	0.96	0	30	30	30	20	17	17	180	180	8262H265	8262H152	2	●	10.1/F	11.6/H
3/8	1/8	0.35	0	210	195	175	135	110	100	167	180	8263H100	8263H104	3	●	17.1/H	22.6/H
3/8	1/8	0.35	0	160	145	125	100	100	70	180	180	8263H070	8263H080 ②	3	●	10.1/F	11.6/H
3/8	5/32	0.54	0	120	110	105	75	65	55	167	180	8263H101	8263H105	3	●	17.1/H	22.6/H
3/8	5/32	0.54	0	90	90	70	60	55	45	180	180	8263H071	8263H081	3	●	10.1/F	11.6/H
3/8	7/32	0.83	0	60	55	55	35	35	30	167	180	8263H102	8263H106	3	●	17.1/H	22.6/H
3/8	7/32	0.83	0	45	45	40	30	25	25	180	180	8263H072	8263H082	3	●	10.1/F	11.6/H
3/8	9/32	0.96	0	38	38	38	25	25	25	167	180	8263H103	8263H107	3	●	17.1/H	22.6/H
3/8	9/32	0.96	0	30	30	30	20	17	17	180	180	8263H073	8263H083	3	●	10.1/F	11.6/H

① Cast UR disc supplied as standard. ② ATEX/IECEx certified with prefix "EV". ● General Purpose Valve.

### Specifications (Metric units)

Pipe Size (in)	Orifice Size (mm)	Kv Flow Factor (m <sup>3</sup> /h)	Min Press	Operating Pressure Differential (bar)						Max. Fluid Temp °C		Catalog Number		Const. Ref	UL Listing	Watt Rating/ Class of Coil Insulation	
				Max AC @ 55°C			Max DC @ 55°C			AC	DC	Brass	Stainless Steel			AC	DC
				Air-Inert Gas	Water	Lt. Oil @ 300 SSU	Air-Inert Gas	Water	Lt. Oil @ 300 SSU								
1/8	1.2	0.05	0	103	95	78	48	41	35	60	60	8262H154 ①	-	1	●	17.1/H	22.6/H
1/8	1.2	0.05	0	114	95	78	48	41	35	60	60	-	8262H167 ①	1	●	17.1/H	22.6/H
1/8	1.2	0.05	0	79	62	55	44	34	22	60	60	8262H155 ①	8262H168 ①	1	●	10.1/F	11.6/H
1/8	1.2	0.05	0	52	52	52	45	39	28	82	82	8262H156	8262H169	1	●	10.1/F	11.6/H
1/8	2.4	0.18	0	24	21	19	16	13	11	75	82	8262H157	8262H172	1	●	17.1/H	22.6/H
1/8	2.4	0.18	0	19	16	12	11	9	7	82	82	8262H128	8262H236	1	●	10.1/F	11.6/H
1/8	3.2	0.30	0	14	13	12	9	8	7	75	82	8262H158	8262H228	1	●	17.1/H	22.6/H
1/8	3.2	0.30	0	11	10	9	7	7	5	82	82	8262H129	8262H237	1	●	10.1/F	11.6/H
1/4	1.2	0.05	0	103	95	78	65	41	35	60	60	8262H159 ①	-	2	●	17.1/H	22.6/H
1/4	1.2	0.05	0	114	95	78	65	41	35	60	60	-	8262H198 ①	2	●	17.1/H	22.6/H
1/4	1.2	0.05	0	79	62	55	44	34	22	60	60	8262H161 ①	8262H199 ①	2	●	10.1/F	11.6/H
1/4	1.2	0.05	0	52	52	52	45	39	28	82	82	8262H260	8262H130	2	●	10.1/F	11.6/H
1/4	2.4	0.18	0	24	21	19	16	13	11	75	82	8262H162	8262H205	2	●	17.1/H	22.6/H
1/4	2.4	0.18	0	19	16	12	11	9	7	82	82	8262H261	8262H134	2	●	10.1/F	11.6/H
1/4	3.2	0.30	0	14	13	12	9	8	7	75	82	8262H163	8262H219	2	●	17.1/H	22.6/H
1/4	3.2	0.30	0	11	10	9	7	7	5	82	82	8262H262	8262H138	2	●	10.1/F	11.6/H
1/4	4.0	0.47	0	8	8	7	5	4	4	75	82	8262H164 ②	8262H223	2	●	17.1/H	22.6/H
1/4	4.0	0.47	0	6	6	5	4	4	3	82	82	8262H263	8262H142	2	●	10.1/F	11.6/H
1/4	5.6	0.72	0	4	4	4	2	2	2	75	82	8262H165	8262H224	2	●	17.1/H	22.6/H
1/4	5.6	0.72	0	3	3	3	2	2	2	82	82	8262H264	8262H148	2	●	10.1/F	11.6/H
1/4	7.1	0.83	0	3	3	3	2	2	2	75	82	8262H166	8262H225	2	●	17.1/H	22.6/H
1/4	7.1	0.83	0	2	2	2	1	1	1	82	82	8262H265	8262H152	2	●	10.1/F	11.6/H
3/8	3.2	0.30	0	14	13	12	9	8	7	75	82	8263H100	8263H104	3	●	17.1/H	22.6/H
3/8	3.2	0.30	0	11	10	9	7	7	5	82	82	8263H070	8263H080 ②	3	●	10.1/F	11.6/H
3/8	4.0	0.47	0	8	8	7	5	4	4	75	82	8263H101	8263H105	3	●	17.1/H	22.6/H
3/8	4.0	0.47	0	6	6	5	4	4	3	82	82	8263H071	8263H081	3	●	10.1/F	11.6/H
3/8	5.6	0.72	0	4	4	4	2	2	2	75	82	8263H102	8263H106	3	●	17.1/H	22.6/H
3/8	5.6	0.72	0	3	3	3	2	2	2	82	82	8263H072	8263H082	3	●	10.1/F	11.6/H
3/8	7.1	0.83	0	3	3	3	2	2	2	75	82	8263H103	8263H107	3	●	17.1/H	22.6/H
3/8	7.1	0.83	0	2	2	2	1	1	1	82	82	8263H073	8263H083	3	●	10.1/F	11.6/H

① Cast UR disc supplied as standard. ② ATEX/IECEx certified with prefix "EV". ● General Purpose Valve.

**Dimensions: inches (mm)**

Const. Ref.		H	K	L	P	W
1	in	3.00	1.54	1.19	2.69	2.06
	mm	76	39	30	68	52
2	in	3.12	1.62	1.56	2.76	2.06
	mm	79	41	40	70	52
3	in	3.20	1.62	1.88	2.77	2.06
	mm	81	41	48	70	52

**IMPORTANT:** Valves may be mounted in any position.

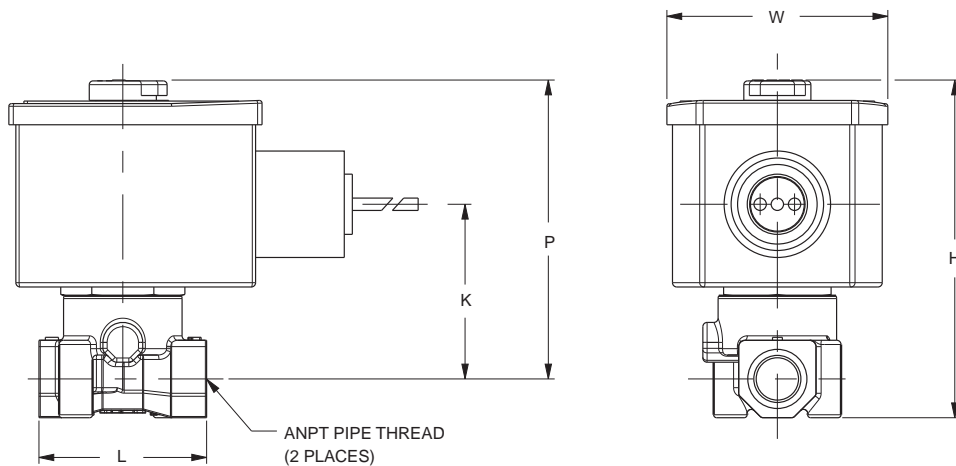
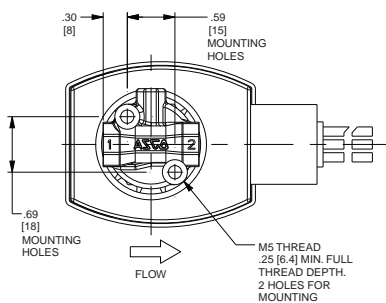
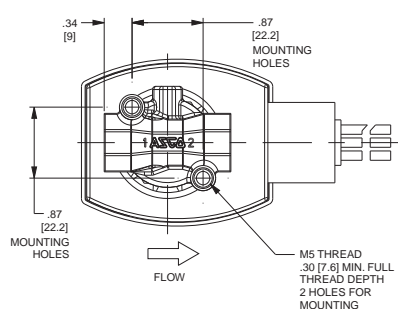
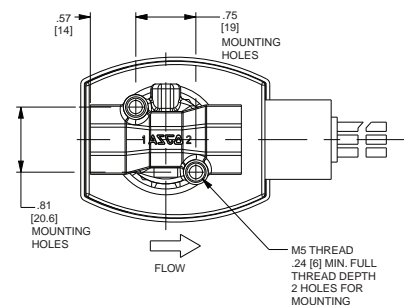
**Const. Ref. 1-3**

**Mounting Dimensions**
**Const. Ref. 1**  
**(1/8" Pipe)**

**Const. Ref. 2**  
**(1/4" Pipe)**

**Const. Ref. 3**  
**(3/8" Pipe)**

**Note:** Mounting holes will accept a standard #10-32 machine screw.