

ControlEdge 900 Platform Input/Output Module Installation

Analog Input Module	900A01 - (current revision number)
High Level Analog Input Module	900A16 - (current revision number)
4 channel Analog Output Module	900B01 - (current revision number)
8 channel Analog Output Module	900B08 - (current revision number)
16 channel Analog Output Module	900B16 - (current revision number)
Digital Input Module (Contact type)	900G01 - (current revision number)
Digital Input Module (Vdc)	900G02 - (current revision number)
Digital Input Number (Vac)	900G03 - (current revision number)
Digital Input, 120/240 VAC, 125 VDC, Isolated	900G04 - (current revision number)
32 Point Digital Input Module (Vdc)	900G32 - (current revision number)
Digital Output Module (Relay)	900H01 - (current revision number)
Digital Output Module (Vdc)	900H02 - (current revision number)
Digital Output Module (Vac)	900H03 - (current revision number)
32 Point Digital Output Module (Vdc)	900H32 - (current revision number)
4 Channel Pulse/Frequency/Quadrature Module (Vdc)	900K01 - (current revision number)
16 Channel Safety Universal Input/ Output Module	900U02 – (current revision number)

Document Number	Form: 51-52-33-125 Effective Date: November 2019 Supersedes: June 2018
-----------------	--

Summary	Enclosed is a new Input/Output module for your ControlEdge HC900 Controller. Use the following procedure for initial I/O module installation with no equipment power. See ControlEdge HC900 Controller Installation Manual for field replacement procedures.
---------	---

CAUTION

Read and understand all of the following information regarding RIUP before attempting to remove and/or replace any I/O module, particularly in a system that is actively controlling a process. All of the I/O Module types in the ControlEdge HC900 System include the Removal and Insertion Under Power (RIUP) feature. That is, while the rack is powered, any of the I/O Modules can be removed or inserted:

- With no physical damage to the module, to the rack, or to other modules in the rack
- Without disturbing the functions of **other I/O modules** in the rack or in the system.

Under carefully controlled circumstances, this feature enables the user to remove and insert an I/O module without completely shutting down a running system. However, it must be recognized that removing or inserting an I/O module under power is potentially hazardous to property and to personnel.

Circumstances that dictate prudent actions depend on conditions and specific process applications at each user facility. It is the responsibility of site personnel to know all potential consequences of RIUP, and to take actions to prevent all adverse consequences before removing or inserting an I/O module under power. Table 1 provides some general guidelines for establishing appropriate procedures at a given installation.

Table 1 - RIUP: Potential Hazards and Recommended Actions

Hazard	Source	Preventive Action(s)
<p>⚠ CAUTION Loss of control or view of a running process can cause damage to equipment and/or to process product.</p>	<p>Each signal at each of the terminals for an I/O module has a specific function. Any or all of the signals may be vital for safely controlling a process.</p>	<p>Either:</p> <p>Using trained personnel and appropriate control mechanisms, transfer to manual control of each signal that is necessary to maintain safe process control.</p> <p>Or:</p> <p>Bring the process to a safe stop before initiating the removal or insertion procedure.</p>
<p>⚠ WARNING Human contact with high voltage sources will result in death or serious injury.</p>	<p>Potentially lethal voltages on Terminal Blocks.</p>	<p>Disconnect all signals at terminal blocks from sources of power before removing the terminal block from the I/O module.</p> <p>Ensure that the Protective Earth (PE) ground is properly connected and properly functioning.</p>

⚠ WARNING 

- Do not use an input/output terminal block if the terminal block is damaged, if the door is missing, or if one or both mounting screws are missing.
- Always tighten both terminal block screws before applying field power to the module.
- Do not apply energized ("live") field wiring to an input/output module that is not installed in one of the racks of the ControlEdge HC900 Controller.
- Do not operate the controller without a Protective Earth connection.
- WARNING – EXPLOSION HAZARD - Substitution of components may impair suitability for Class I, Division 2.
- AVERTISSEMENT - RISQUE D'EXPLOSION – LA SUBSTITUTION D'E COMPOSANTSP EUTR ENDRE CE MATERIEL INACCEPTABLE POUR LES EMPLACEMENTS DE CLASSE I, DIVISION 2.
- WARNING – EXPLOSION HAZARD – Do not connect while circuit is live unless area is known to be nonhazardous.
- AVERTISSEMENT - RISQUE D'EXPLOSION. NE PAS DEBRANCHER TANT QUE LE CIRCUIT EST SOUS TENSION, A MOINS QU'IL NE S'AGISSE D'UN EMPLACEMENT NON DANGEREUX.

Failure to comply with these instructions could result in death or serious injury.

ControlEdge HC900 Hardware

Controller Rack Assembly

1. Rack, available in 4- 8-, or 12-slot versions
2. Power Supply
3. Controller CPU Module
4. Grounding bars (for I/O wiring; optional)
5. Input/Output modules
6. I/O Terminal Blocks

Most of the components in an I/O expansion rack are identical to those used in the Controller Rack. The only difference is the Scanner Module (item 3) that occupies the same rack location as the Controller CPU Module in a Controller Rack.

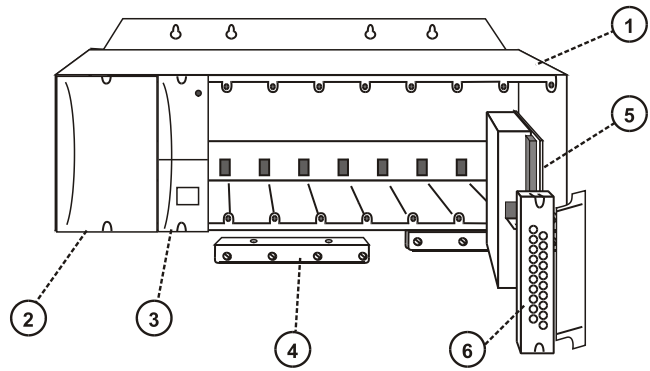

Figure 1

Contents

Each Input and Output module is supplied in a static protective shipping bag and includes an appropriate identification label. The I/O module should be stored in the shipping bag until ready for installation. The identification label will be installed in the see-through cover of the terminal board assembly.

Installation Guidelines

Although any I/O module may be inserted into any open slot in a rack and operate, some recommendations are provided here to reduce the potential for external influences to impact controller performance.

1. Place low energy I/O modules such as analog inputs and analog outputs in slot locations nearest the controller or scanner module.
2. Place high energy switching modules such as AC and relay outputs away from the controller or scanner module.
3. Observe the guidelines in the installation manual when it is anticipated the controller will be operating in ambient temperatures above 55 degrees centigrade.
4. Use no more than 10 Analog Output modules per rack and no more than 8 PFQ modules per rack.

Installation Procedure

Follow the procedure in Table 1 to install an I/O module in a controller rack or I/O expansion rack.

Table 1 – Initial I/O Module Installation

Step	Action
1	Orient the controller rack to have the open side of the enclosure facing forward with the power supply and controller or scanner modules located on the left (See figure 1).
2	For High Level AI module set DIP switches for voltage or current. For 8 or 16 Analog Output module set DIP switch on for internal rack power, off for external 24VDC power. For PFQ module, set DIP switches for singled-ended or differential. See ControlEdge HC900 Controller Installation and User Guide (document #51-52-25-107) for I/O installation details.
3	Remove the I/O module from its shipping bag and insert into the desired rack and slot location. Orient the plastic light pipes of the module to the right when inserting the card to obtain proper vertical orientation. Press the I/O module into the slot until the rear connector engages the mating connector of the rack backplane.
4	Identify the proper terminal board assembly for the specific I/O module type. Match red terminal board connectors with red mating connectors of the I/O modules and black terminal board connectors with black mating connectors of the I/O modules.
5	Remove inappropriate keying tabs from the backside of the terminal board assembly to allow proper mating of the terminal board with the module. Once the keying tabs are removed the terminal board may only be mated with an appropriate module type. See ControlEdge HC900 Controller Installation and User Guide (document #51-52-25-107) for keying tab details.
6	Slide the terminal board assembly onto the I/O module being careful to align the module light pipe assembly with the cavity provided on the hinged cover side of the terminal board assembly. Secure the terminal board, top and bottom, with the mounting screws.
7	Insert a small flat screwdriver into the slots of the tool secured terminal board cover and pull to open the door.
8	Place the module label included with the module into the terminal board cover using the small tabs located at the top and bottom of the inside cover. Insert the label with the color band on the top and facing forward when the cover is closed.
9	<i>For wiring quadrature differential mode, use reverse polarity (+ to -) for Input 1, Input 2 and Index.</i>

See ControlEdge HC900 Controller Installation and User Guide (document #51-52-25-107) for module replacement procedures.