

Jerguson® LumaStar™

(EPL-100 & EPL-316)

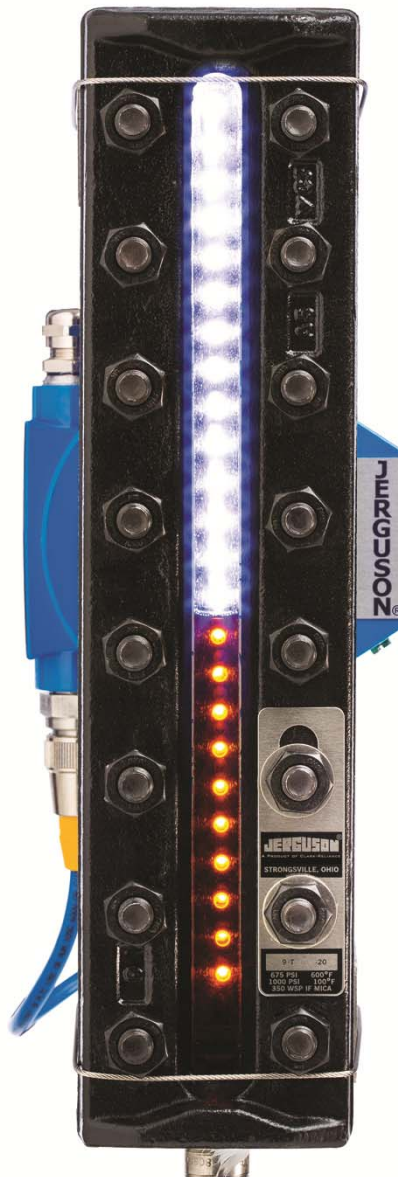

JERGUSON®
A PRODUCT OF CLARK-RELIANCE

STORAGE and HANDLING

The Jerguson® LumaStar™ Explosion Proof LED Illuminator meets or exceeds all applicable specifications when shipped from the factory.

All units should be inspected upon receipt to ensure that no damage has been incurred during transit. If there has been damage, a claim should be filed with the carrier immediately. Unit should be stored in an area protected from the elements and corrosive fumes, in a secure manner where they can neither fall, nor be struck by other objects. Care should be taken to protect the window and the end connections from damage. Avoid placing any objects directly on the light at any time.

COMPONENTS

There are three main components that make up the LED illuminator: the light strip, power supply, and cable connecting these two main pieces. The cable may have more than one piece depending on the required distance between the illuminator and power supply. Questions regarding acceptable applications should be directed to The Clark-Reliance® Corporation.

ELECTRICAL CONNECTION

CAUTION: All lights are tagged with the service conditions for that particular unit. These specifications are located on the Jerguson® tag on the power supply housing, and are contained in the “Specifications” section of this manual. Review the ratings prior to installation and again prior to start-up.

Note: All installation steps should be performed by a qualified technician and should be executed in accordance with all applicable national and local codes.

The light and power supply should be checked to ensure that they contain no foreign matter, and that the end connections are clean and undamaged.

NOTE: If desired, the light may be installed onto the glass gauge prior to connecting electrical.

CAUTION: Before working with power supply, verify that the area is free of flammables and AC power circuit is off.

- 1) Open the cover of the power supply housing. Insert the AC Line wires into the housing and connect to the “AC IN” terminal block. Ground screws are located inside and outside the enclosure. **CAUTION:** The DC output is pre-wired. If this connection is removed during installation, reconnect the “AC IN” and “DC OUT” to the proper positions. Failure to do so will result in permanent damage to the power supply. (Ref. Fig. 14, pg. 9)

NOTE: All model EPL-316 power supplies are remote mount.

- 2) **IMPORTANT: A sealing fitting must be installed within 18” of the enclosure when mounting in Hazardous Locations.**
- 3) If the cable will not reach the power supply, contact your local representative for the required extension cable.
- 4) Replace the cover on the power supply housing.
- 5) Switch “ON” the power supply making sure the Illuminator is functioning properly, with all LED’s illuminated.
- 6) Refer to the troubleshooting section in this manual if a portion or all of the LEDs do not illuminate.

ROUTINE MAINTENANCE

Keep window on the front of the light clean using commercial glass cleaners, such as Windex® or similar. Never use harsh abrasives, wire brushes, metal scrapers, or any material that could scratch the window. The window may be cleaned while the unit is in operation.



INSTALLATION ONTO GLASS GAUGE

UNIVERSAL BRACKET

*NOTE: Illuminator pictured is model EPL-100. Model EPL-316 mounts in the same manner except the power supply is always remote mounted. Identify your bracket type. Confirm the bracket style matches that in the below pictures. If the bracket received does not match the illustrations below, see page 5 or 6 for alternate bracket styles.

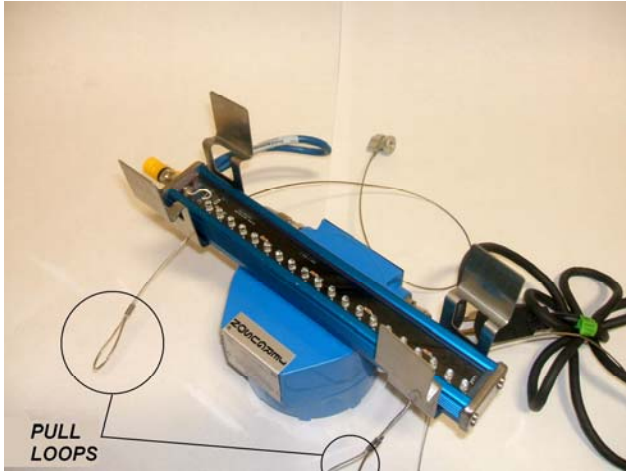

Figure 1

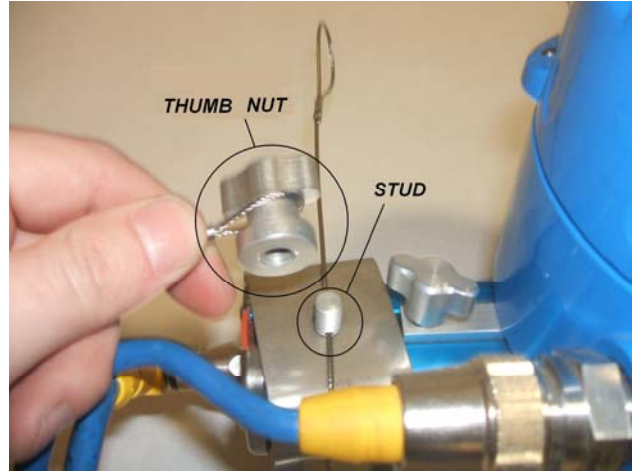

Figure 2

Step 1: Check to make sure brackets are properly assembled on the illuminator. The cable should be fed through the stud protruding from behind the illuminator, locking in the bracket as shown above in Figure 2. One end of the cable should be crimped into an oval for pulling leverage and the other should be crimped securely around a thumb nut.

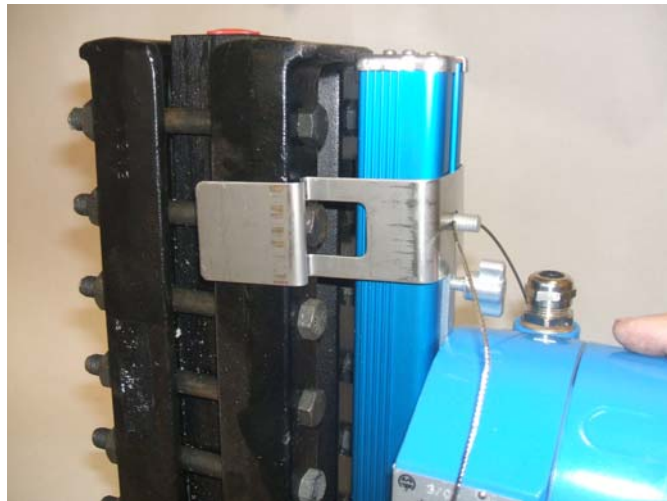

Figure 3

Step 2: Press Jerguson® LumaStar™ assembly against rear of gauge as shown in Figure 3, aligning the bracket cutouts over the gauge bolt heads as shown. Align the brackets with the 2nd set of bolts in from each end of the gauge, when possible. Note that all one-section size 7 models and smaller will require the power supply to be remote mounted.

JERGUSON®
A PRODUCT OF CLARK-RELIANCE

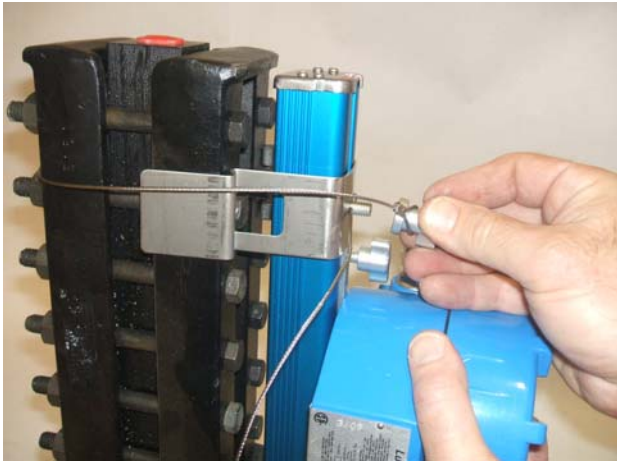

Figure 4

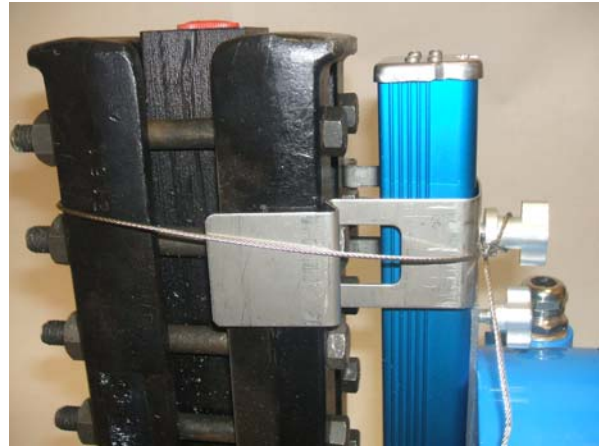

Figure 5

Step 3: While holding the top bracket in place, grab the thumb nut end of the cable, wrap around entire gauge and thread onto the stud until the bracket is secure. When wrapping the cable around the gauge, make sure to feed the cable above the bolt as shown above in Figure 5. Snug the cable and secure the thumb nut, but do not fully tighten the thumb nut at this time.

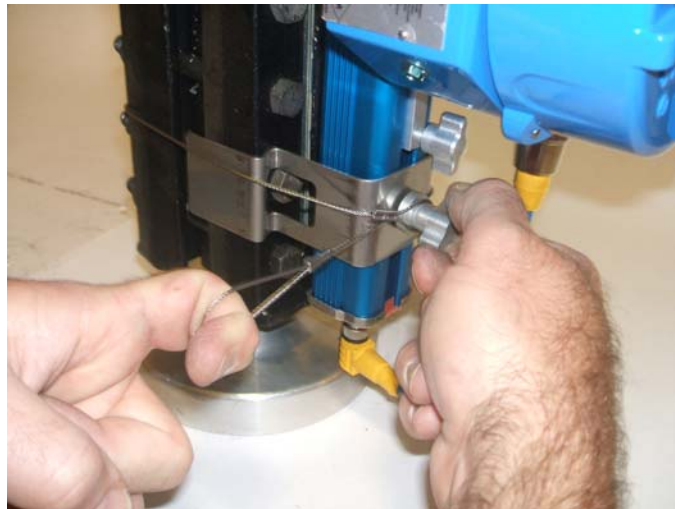

Figure 6

Step 4: Align bottom bracket, using the 2nd bolt if possible. Wrap thumb nut end of the cable around the entire gauge and begin to thread. Pull the cable loop as tight as possible and fully tighten the thumb nut down as shown in Figure 6. The lower bracket should now be tight and secure.

JERGUSON®
A PRODUCT OF CLARK-RELIANCE



Figure 7

Step 5: After the lower bracket has been tightened, go back to the top bracket and loosen the thumb nut enough to allow the cable to slide through freely. Pull cable as tight as possible, and fully tighten thumb nut as shown in Figure 7.



Figure 8



Figure 9

Step 6: The Jerguson® LumaStar™ is now properly installed. Feel free to tuck any excess cable inside itself or allow it to hang freely. This adjustable assembly is appropriate for any gauge with a cover width not exceeding 4.375 inches (111 mm).

JERGUSON®
A PRODUCT OF CLARK-RELIANCE

ALTERNATE BRACKET STYLE

*NOTE: Illuminator pictured is model EPL-100. Model EPL-316 mounts in the same manner except the power supply is always remote mounted. Identify your bracket type. Confirm the bracket style matches that in the below pictures. If the bracket received is different than shown here and on page 2, contact factory for assistance.

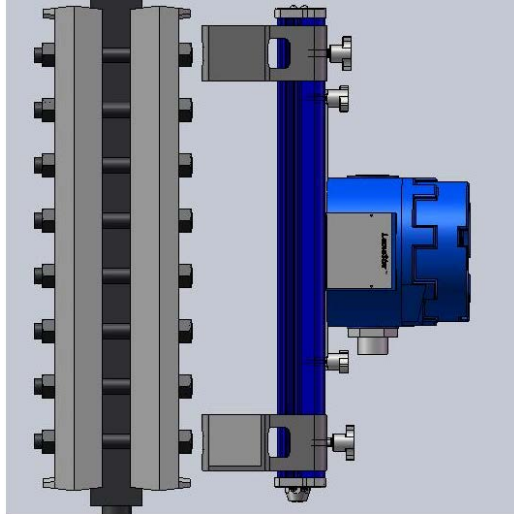

Figure 10

- 1) Align Jerguson® LumaStar™ assembly with rear (side with bolt heads) of gauge. Loosen bracket thumb nuts and adjust the position of the brackets to line up with their respective bolts on the gauge as shown in Figure 10. Tighten the thumb nuts to secure in place. When possible, use the 2nd set of bolts from the edge of the cover plate. Note that all one-section size 7 models and smaller will require the power supply to be remote mounted.

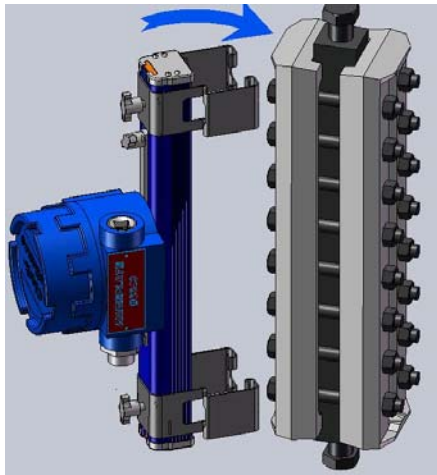

Figure 11

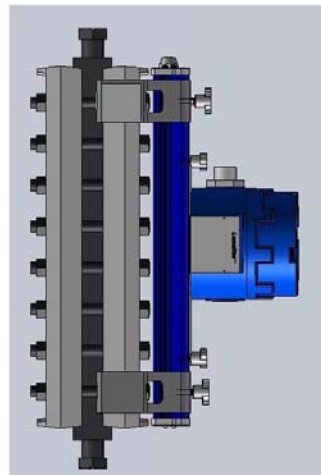

Figure 12

- 2) Align one side of the brackets as shown in Figure 11, so that the clip of the brackets are gripping around the side of the gauge. Roll the entire assembly over until it is flush with the rear flat of the gauge and press until the bracket clips have locked into place as shown in Figure 12.

JERGUSON®
A PRODUCT OF CLARK-RELIANCE

REFLEX BRACKET STYLE

*NOTE: Illuminator pictured is model EPL-100. Model EPL-316 mounts in the same manner except the power supply is always remote mounted. Identify your bracket type. Confirm the bracket style matches that in the below pictures. If the bracket received is different than shown here and on page 2, contact factory for assistance.

NOTE: installation onto a Reflex Gauge requires removal of nuts on the gauge. Do not install illuminator with gauge in service.

- 1) Install the brackets onto the illuminator leaving the bracket thumb screws loose. The brackets should move freely up and down in the illuminator channel.
- 2) Remove top and bottom nuts from the Reflex Gauge on the side of the gauge that the illuminator is to be installed on.
- 3) Position brackets onto studs, reinstall gauge nuts and tighten to the torque specified for your gauge.
- 4) Position illuminator so it is centered on the Reflex Gauge and tighten the bracket thumb screws. The illuminator should be mounted as shown in Figure 13.

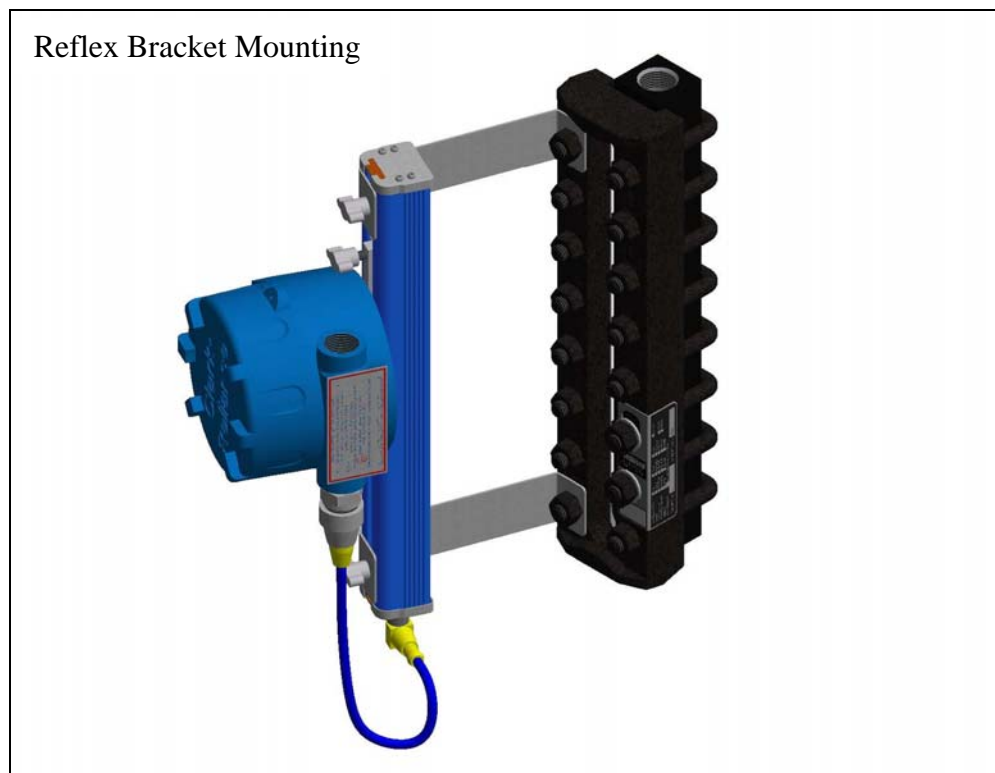

Figure 13

JERGUSON®
A PRODUCT OF CLARK-RELIANCE

SPECIFICATIONS

Power Supply:	120 or 240 VAC @ 50-60 Hz
Power Consumption:	< 750 mA @ 120 VAC < 375 mA @ 240 VAC
Est. Life:	100,000 Hours (continuous)
Approvals:	FM Class I, Div. 1 Groups B, C, D T4 CSA Class I, Div. 1 Groups B, C, D T4 Associated Equipment [Exia]
Ambient Temp:	-40 F (-40 C) to 170 F (77 C)
Wire Size:	Min 18 AWG / Max 12 AWG
Max dist. power supply to light:	72 feet (22M)
Electrical Connection:	¾" FNPT

Jerguson® EPL-100 / EPL-316 LumaStar™ Spare Parts	
Description	Part Number
Universal Bracket Assembly (2 required / light strip)	(1) S24245 (ea.) (EPL100 only)
	(2) S24245 (set) (EPL100 only)
115 VAC FM / CSA Power Supply Board / Bracket Sub-Assembly	S23293
230 VAC FM / CSA Power Supply Board / Bracket Sub-Assembly	S23294
115 VAC FM / CSA Power Supply w/ Epoxy Coated Aluminum Explosion-Proof Enclosure	S23213 (Std. for EPL 100)
230 VAC FM / CSA Power Supply w/ Epoxy Coated Aluminum Explosion-Proof Enclosure	S23295 (Std. for EPL 100)
115 VAC FM / CSA Power Supply w/ 316 SS Explosion-Proof Enclosure	S24932 (Std. for EPL 316)
230 VAC FM / CSA Power Supply w/ 316 SS Explosion-Proof Enclosure	S24933 (Std. for EPL 316)
Fuse (400 mA, Ceramic Cartridge, ATEX Certified)	E-F-DIN-F400MA (4 Fuses)
18" Cable w/ 90 degree Connector (Power Supply to 1st Light Strip)	V20509
6-1/2 foot (2 meter) Extension Cable (Nickel Plated Brass connectors for Remote Mounting)	V20601-6.5
2-1/2 foot (.75 meter) Daisy-Chain Cable (Nickel Plated Brass Connectors)	V20601
6-1/2 foot (2 meter) power cord w/ 90 degree connector (Power Supply to 1 st Light Strip w/316SS Connectors)	V21249
2-1/2 foot (.75 meter) Daisy-Chain Cable (316SS Connectors)	V21319
LED Array Circuit Board (4 inch)	S23174-4 (EPL100 only)
LED Array Circuit Board (6 inch)	S23174-6 (EPL100 only)
LED Array Circuit Board (8 inch)	S23174-8 (EPL100 only)
LED Array Circuit Board (10 inch)	S23174-10 (EPL100 only)
LED Array Circuit Board (12 inch)	S23174-12 (EPL100 only)
M20 metric brass adaptor (3/4"MNPT x M20 female)	V19705-F



Troubleshooting

Description of Problem	Possible Cause	Troubleshooting Procedure
All LEDs out	No AC line voltage Blown Fuse Loose or disconnected DC output wires Blue Power Cord loose or connector damaged Loose or damaged connections inside LED Assembly Damaged Power Supply	Follow troubleshooting steps below
Set or sets of (4) LEDs out	Defective LED Board	Contact Factory
LEDs out above a certain point	Loose connection between LED boards Defective LED board	Contact Factory
LEDs out in group (more than 4)	Defective LED board	Contact Factory

Troubleshooting Steps

Caution: Some of these troubleshooting steps are performed with live voltage applied. The assembly should be moved to a safe area before beginning work. A qualified and properly trained technician must perform these steps.

NOTE: See Figure 14 on next page for component locations.

- 1) Remove enclosure cover and look to see if red LED power indicator is on.
 - a) If red LED is on, go to step 4.
- 2) Check AC wiring to make sure it is properly installed and tightened in connector.
- 3) Using a meter, verify AC line voltage at AC connector.
- 4) Disconnect AC power. Using a small pair of needle-nose pliers, gently remove fuse from holder.
- 5) Check fuse for continuity with an Ohm meter. If there is continuity, re-install fuse. If there is no continuity, replace fuse.
- 6) Check DC output wiring to make sure it is properly installed and tightened.
- 7) Reconnect AC power.
- 8) Using a voltmeter set to DC; measure the voltage across the output connector. Voltage should be between 9VDC and 15VDC.
- 9) Unscrew and remove blue power cord. Inspect the 4 pins inside end connector to make sure they are straight and undamaged. If pins are bent, use a small pair of needle-nose pliers to straighten bent pins. If pins are missing, contact factory.
- 10) Reconnect power cord making sure connectors are fully seated and tightened.
- 11) If all steps above check OK, contact factory for support.



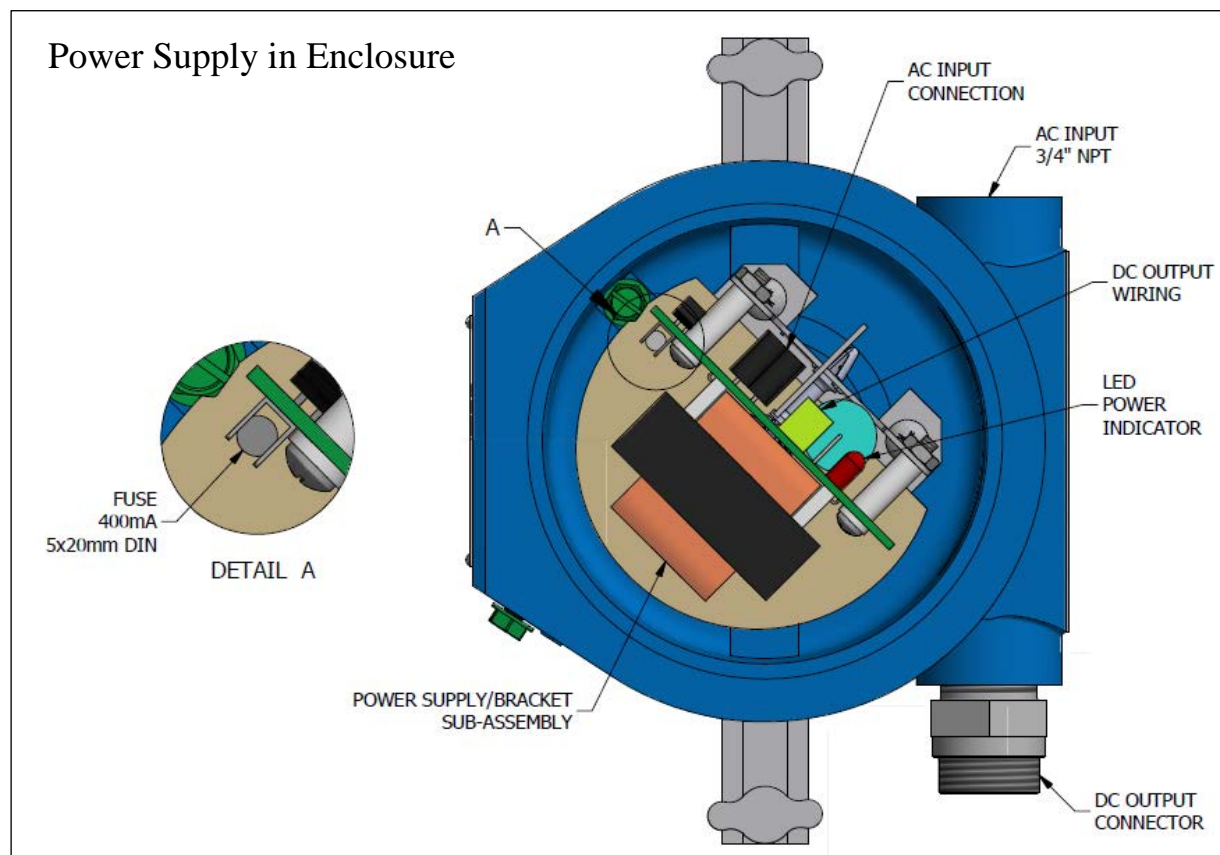

Figure 14: Power Supply in Enclosure

REPLACEMENT OF POWER SUPPLY AND HOUSING ASSEMBLY FOR MODEL EPL-100

NOTE: Make sure AC power is off before removing cover.

- 1) Loosen cover locking screw and open the cover of the power supply housing. Disconnect AC power and remove AC wires from enclosure.
- 2) Remove assembly from gage and relocate to desired work area.
- 3) Disconnect power cable between power supply and light bar assembly.
- 4) Trim gasket material at top end cap to match slot opening and slide out top bracket and mounting hardware.
- 5) Loosen power supply screws and slide power supply off light bar assembly.
- 6) Slide new power supply onto light bar assembly.
- 7) Insert bracket and mounting hardware for top bracket back into slot.
- 8) Securely tighten the power supply screws and the top bracket screw.
- 9) Install power cord between power supply and light strip making sure connectors are fully connected.
- 10) Bench test unit by applying AC through AC Input Connector (ref. Figure 14).
- 11) Re-install on gage and reconnect AC power.



REPLACEMENT OF POWER SUPPLY SUB ASSEMBLY (ALL MODELS)

(P/N S23293 and S23294)

NOTE: Make sure AC power is off before removing cover.

- 1) Loosen cover locking screw and open the cover of the power supply housing. Disconnect AC power and remove AC wires from enclosure.
- 2) Remove assembly from gage and relocate to desired work area.
- 3) Unplug DC power plug.
- 4) Remove 2 screws holding power supply sub assembly in place. See Figure 15.

NOTE: Screws are installed with Loctite. If screws will not come loose, sharply hit the back of the screwdriver with a hammer to help release the hold of the Loctite.

- 5) Place new power supply into position in the enclosure, apply permanent liquid thread lock to the screws and reinstall screws.
- 6) Re-connect DC power plug and bench test unit by applying AC through the AC Input Connector (ref. Figure 1).
- 7) Re-install on gage and reconnect AC power.

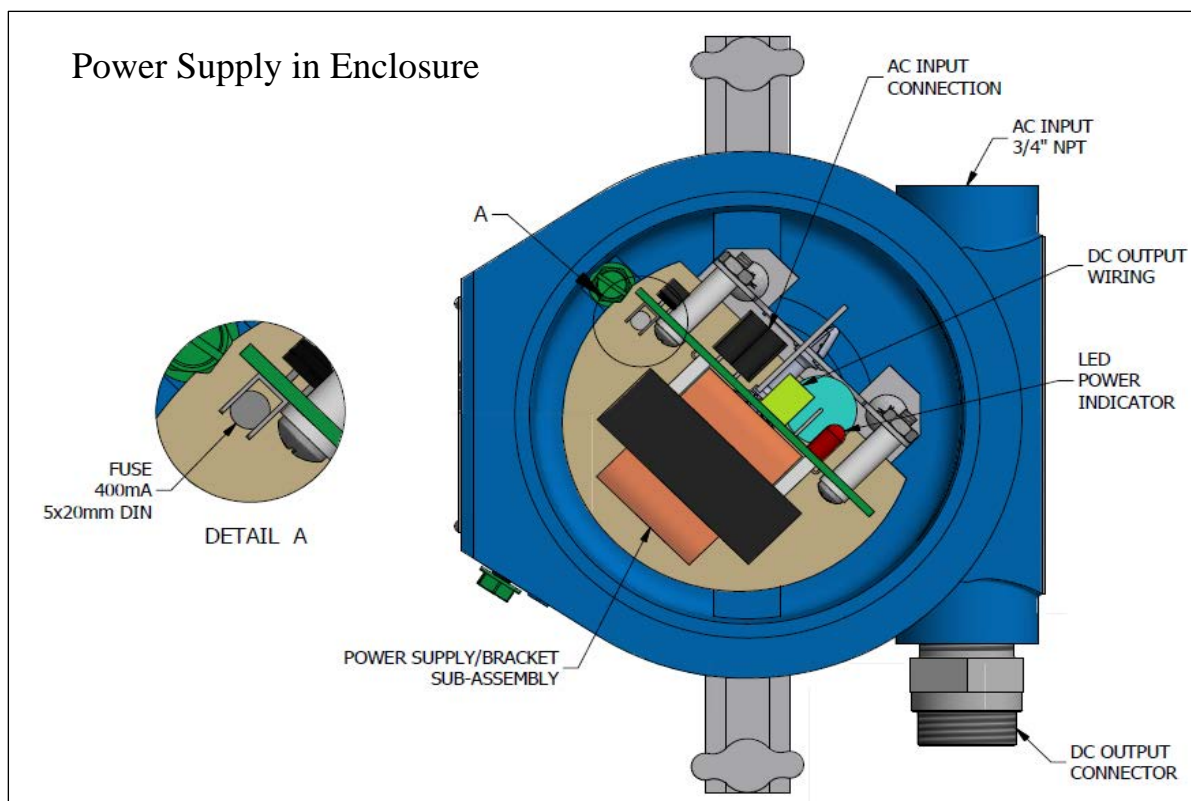

Figure 15

JERGUSON®
A PRODUCT OF CLARK-RELIANCE



On-Line Parts - *DIRECT* - for Clark-Reliance® Products

JERGUSON®

Reliance®

MAGNE-SONICS™

JACOBY-TARBOX®



www.clark-reliance.com/parts

JERGUSON®
A PRODUCT OF CLARK-RELIANCE