

# QUICK REFERENCE GUIDE

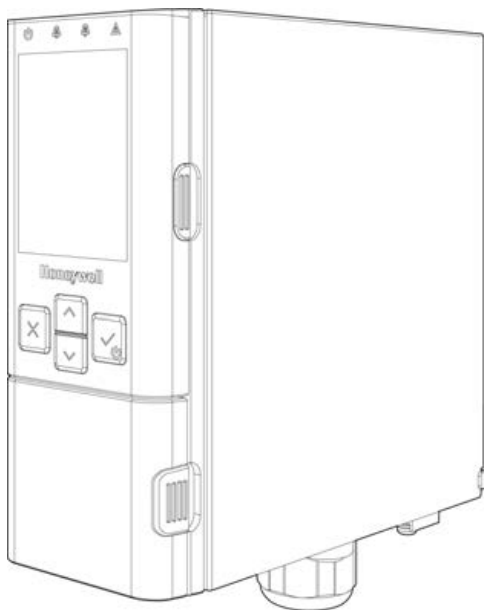

## **Midas® S2**

Fixed single-point extractive gas transmitter

**Honeywell**

## Product Description

The Midas® S2 is a Fixed, Extractive Single-Point Gas Transmitter that draws a sample locally or from a remote point to a sensor cartridge. A wide range of toxic, flammable and oxygen gas sensor cartridges are available that enable the detection of gases used or generated in semiconductor manufacturing operations, light manufacturing environments, and national and university labs that specialize in semiconductor processing research.

### Features & Benefits:

- Highly modular design for easy, reliable, and trouble-free installation.
- Quick replacement of cartridges and pump parts for simple maintenance.
- Single, smart sensor cartridge with onboard \* 'e-calibration' certificate
- 3-built-in relays (Form C) for Alarms 1, 2, and Fault
- Supportive digital communication (Modbus/TCP ethernet/Power over Ethernet (PoE))
- Keypad interface
- Factory-calibrated sensors to reduce the need for frequent gas testing
- 4-20mA analog output with fault and event reporting
- Large, bright, and rich TFT color LCD and extensive viewing angle.
- mA communication protocols for easy connectivity and service interaction
- Robust extractive pump system (2-year lifetime) sampling up to 100 feet
- Designed to ensure maximum uptime while providing a delightful user experience while using the machine and providing a low cost of ownership for the customers
- Supportive Digital communication (Modbus / TCP Ethernet / Power over Ethernet (PoE) )
- Block test to ensure sampling line connection and no leakage



### **CAUTION RISK OF INJURY AND PROPERTY DAMAGE**

- To minimize the risk of electrostatic charging, provide a suitable ground connection, and install the equipment in such a way that no accidental discharges occur.
- When Midas S2 reaches the end of its life, it should be disposed of by local regulations.
- Do not use cleaning solvents or abrasives to clean the gas detector.
- Do not attempt to modify the product in any way from the manufacturer's design or specification. Warranty will be void and malfunction of the gas detector may result.
- Use only genuine spare parts and accessories with Midas S2. Malfunction may result if non-standard parts are used.
- Midas® S2 is suitable for ordinary locations only and must not be installed in hazardous locations.
- Installation must be by the recognized standards of the appropriate authority in the country concerned. For Europe, see EN60079-14, EN60079-29-2, and EN61241-14. For installations in North America, the National Electrical Code (NFPA 70) should be strictly observed. All the appropriate local and national regulations should be observed.
- Indoor use only.

## Certifications

<b>Electrical:</b>	UL	61010-1,
	CSA	C22.2 No.61010-1,
	IEC	61010-1,
	EN	61010-1



**ROHS:** 3(EU 2015/863)



**EMC:** EN 50270:2015



## What's in a full box System

- Midas® S2 transmitter
- Installation accessories (tubes, tube adaptor or LIT check valve if ordered)
- Quick reference guide
- ROHS sheet with drill template

## Hardware overview

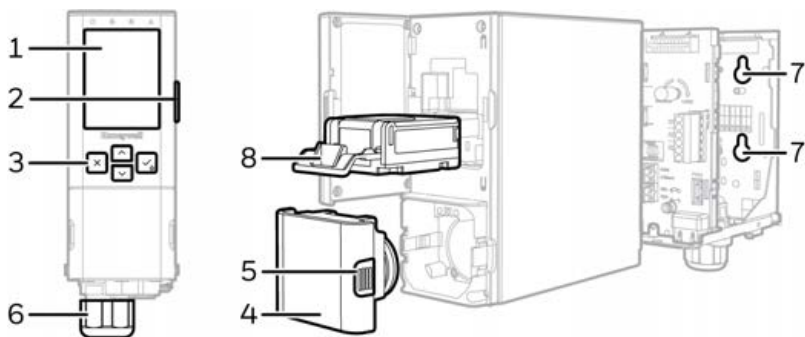

1	Display	2	Pump door latch
3	Navigation buttons	4	Sensor cartridge
5	Sensor release latch	6	Cable gland
7	Mounting holes	8	Pump module

## User Interface overview

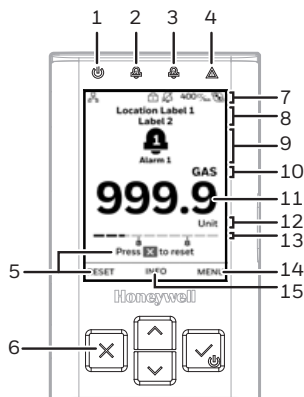

1- Power LED 

2- Alarm 1 

3- Alarm 2 

4 - Fault 





5 - Tips for reset faults or alarms







8- Location label





6 - Buttons

7 - Device status icons

9 - Main status icons

	Cancel. Reset alarm or fault
	Accept Power on
	Up
	Down

	Network connected
	Network not connected
	Password enabled
	Inhibit mode is enabled
	400 $\frac{CC}{min}$ Flow rate
	Internal pump running

	Normal
	Alarm 1
	Alarm 2
	Fault
	Inhibit mode

10- Gas name

11 - Gas concentration

12 - Unit

13 - Bar graph for gas  
concentration display

14 - Menu

15 - Information

## Specifications

<b>Transmitter Dimension</b>	
Size (unit with Cartridge)	138.6 (H) x 55 (W) x 148 (D) mm (5.46 x 2.17 x 5.83 in)
Weight - Transmitter	1.03kg (2.27lb)
Weight - Sensor cartridge	34~73 g (0.075~0.161 lb) dependent on sensor type
<b>Power Requirements</b>	
Operating Voltage	24 VDC Nominal, -15 to +10% (20.4 to 26.4 VDC)
Operating Voltage with Power over Ethernet (PoE)	48 VDC PoE (IEEE 802.3af compliant)
<b>Power Consumption</b>	
Transmitter unit (normal condition) <sup>1</sup>	Typ. <5W
Transmitter unit (full load condition) <sup>2</sup>	< 12.95W (with Pyrolyzer)
<b>Outputs</b>	
Visuals	Power, alarm Fault LEDs and color TFT LCD
Relays	Alarm1, Alarm2, Fault relay rated 1.0A@30VDC or 0.5A@125VAC max
Analog	Sink/Source, 4-20mA
Digital Communications	Modbus/TCP Ethernet/Power over Ethernet (PoE)
<b>Display</b>	
Size/color	2.4inch IPS panel with 16.7M display color
Viewing angle	160 or higher degree viewing angle
Operation key	4-button interface keypad
<b>Transport System</b>	
Flow Rate	500 mL/min
Sample Line Tubing	3.18mm ID X 6.35mm OD (0.125 X 0.25in)
Sample line Length	Up to 30 m (100 ft) with FEP tubing
Exhaust Line Tubing	4.76 mm ID X 6.35 mm OD (0.188 X 0.25 in)

Exhaust Length	Up to 30 m (100 ft)
Ambient Point	In line air filter required
<b>Environmental</b>	
Operating temperature	0°C to +40°C (32°F to 104°F) 0°C to 30°C (32°F to 86°F) with Pyrolyzer
Condition	Indoor only
Operating atmospheric pressure	80~120Kpa
Altitude	<2000m
Overvoltage	Category 1
Pollution degree	2
<sup>1</sup> Normal condition: (1) No gas alarm, (2) Without tube and pressure/vacuum. <sup>2</sup> Full load condition: (1) Gas alarm is on, (2) Maximum tubing length and pressure/vacuum on the inlet/exhaust line.	

## Cleaning the system

Clean the exterior of the instrument with a soft, damp cloth. Use only water-based (non-alcohol) cleaners. Do not use soaps, solvents, or polishes.

## Mount the Device

Mounting the device on a vertical flat surface.

1. Unscrew the two screws located on the main module.

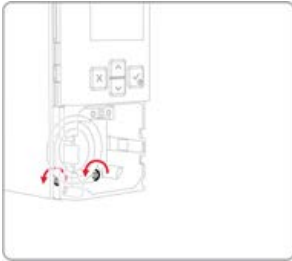

2. Remove the main module by pulling it forwards off the base module. At this time, hold the cable gland in the base module with one hand, and with the other hand, carefully pull the main module.

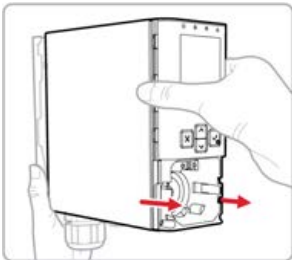

3. Unscrew the retaining screws located at the base module, and then, remove the back plane PCB module.



4. Drill two holes 2.3in (58.50mm) vertically apart for 2 x round head M4 screws, using the separately provided drill template on the ROHS sheet.

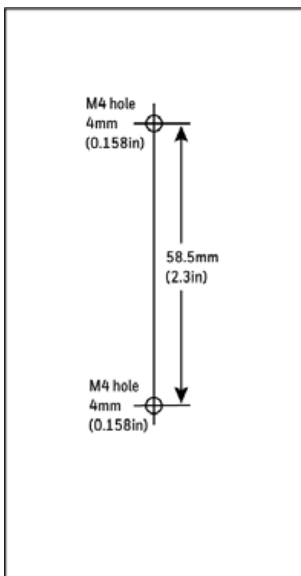

5. Partially screw the fixings into the mounting surface.
6. Place the mounting bracket assembly over the screws, so they pass through the mounting holes and then slide down to locate in the slots.

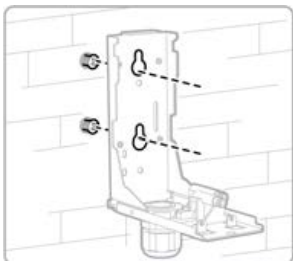

7. Tighten the screws to secure the mounting bracket assembly.

8. Align the RJ45 socket of the power PCB module in the hole of the mounting bracket to refit the PCB.

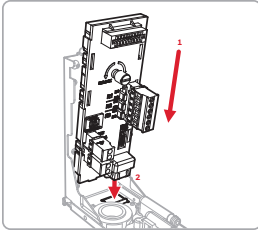

9. Tighten the retaining screw to secure the power PCB module.

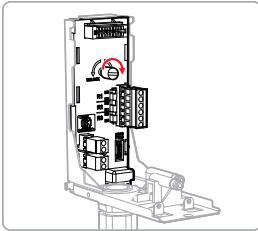

10. Wire the device as described in the "Wiring" section.  
11. Place the main module back into the base module.

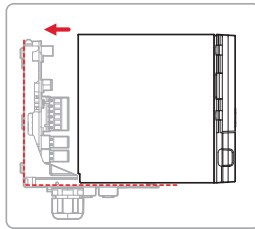
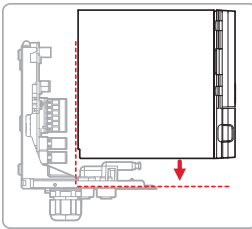

12. Screw the two screws located on the main module, as identified in Step 1.

## Wiring

Access for the electrical wires to the terminal module is made via the PG16 cable gland located at the bottom of the mounting bracket assembly. The cable gland can be removed and replaced with a suitable conduit fitting if required.

The terminals used are suitable for conductors of 24 to 14 AWG (0.5 to 1.8mm Dia.). We recommend using the 16 AWG (1.5 mm Dia.) conductors.

### Terminal layout of the base module

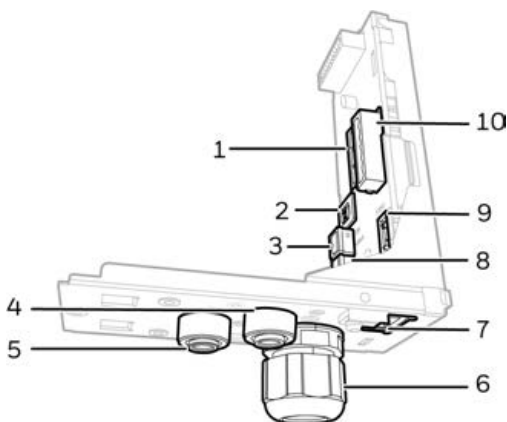

1	Relay NO/NC jumpers	2	4-20mA analog sink/source switch
3	4-20mA analog output terminals	4	Gas outlet port
5	Gas inlet port	6	Cable entry
7	RJ45 connector for ethernet/PoE	8	24Vdc Power terminals
9	Pyrolyzer or NDIR connector	10	Relay Contact terminals

Midas S2 can be powered by either 24 VDC via traditional discrete wiring or by approximately 48 VDC delivered through the Ethernet cable from a PoE source. In either case, the 4-20 mA analog output can be used.

## NOTES:

- Midas S2 allows only one power source, 24 VDC or PoE. Failure to observe this requirement may cause damage to the gas detection system and will not be covered by the standard warranty
- Earthing Requirements: If the Midas S2 unit's mounting bracket is not connected directly to a metal surface for earthing purposes, an additional earth wire will be required. Connect a wire via the PG16 gland to the dedicated earth tag (screw terminal) located on the bottom bracket and connect the other end of the wire to a dedicated external earthing point. If Power over Ethernet (PoE) power supply is being used, shielded CAT5 or equivalent Ethernet cable is recommended. Please ensure that your wiring avoids earth ground loops that may affect the performance of your equipment.
- Instrument grounding is required to ensure stable performance and to limit the effects of radio frequency interference before installation.

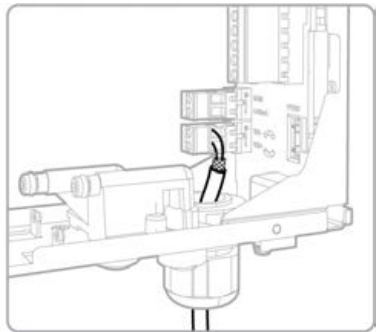
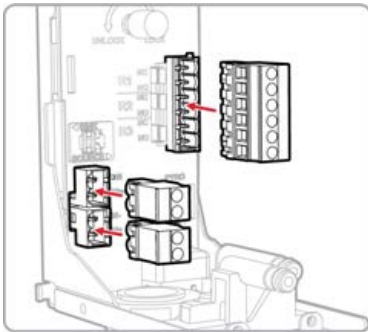

- Pull the terminal blocks to remove them from the connector module.
- Connect the cables to the terminal blocks, referring to the relevant wiring diagram. Strip and insert the end of each wire into the corresponding terminal hole. Using a flat-blade terminal screwdriver, tighten the terminal screw until the wire is secured. Use a ferrule on the wire when necessary.

**IMPORTANT:** Do not over-tighten the terminal screw.

**NOTE:** When wiring the Midas S2 Transmitter to a controller, program the controller for a 1-2 second delay before reporting to prevent false alarms.

## Electrical installation

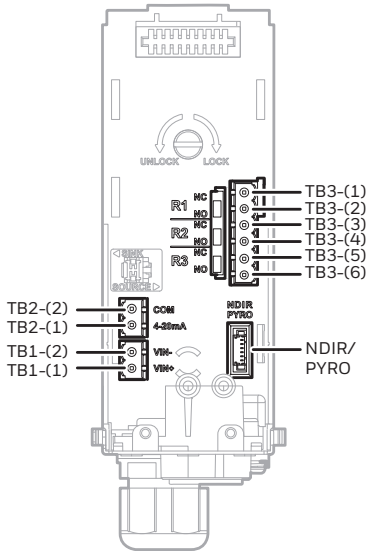

Reference	Category	Description
TB1-(1)	DC power	24Vdc input – VIN+
TB1-(2)	DC power	0Vdc – VIN-
TB2-(1)	mA output	4-20mA analog output
TB2-(2)	mA output	COM
TB3-(1)	Relay1	Alarm1 – COM
TB3-(2)	Relay1	Alarm1 – NO/NC (default NO)
TB3-(3)	Relay2	Alarm2 – COM
TB3-(4)	Relay2	Alarm2 – NO/NC (default NO)
TB3-(5)	Relay3	Common Fault – COM
TB3-(6)	Relay3	Common Fault – NO/NC (default NO)
NDIR/PYRO		Pyrolyzer or NDIR connector

**Relay rating :** 1.0A@30VDC or 0.5 A@125 VAC max.

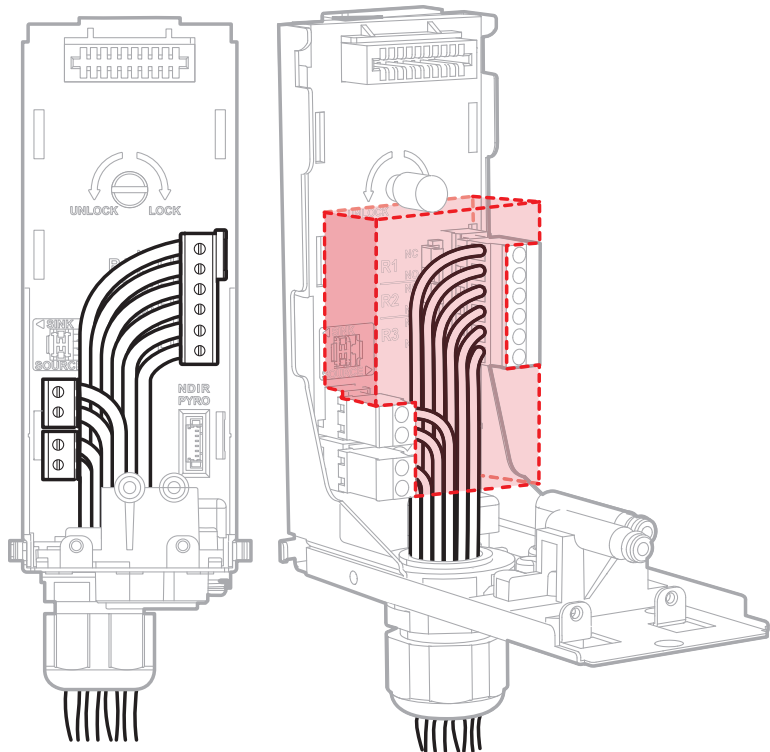

Note: Wiring should be executed within the red area.

## Attach the pyrolyzer or NDIR

1. Remove the main module as described in the Mount the Device process.
2. Plug the connector into the socket (as indicated in the image) at the bottom right of the terminal module through the rectangular access of the mounting bracket. Align the fitting at the top rear of the pyrolyzer or NDIR with the gas inlet port at the bottom of the mounting bracket.
3. Connect the pyrolyzer or NDIR to the detector with the three provided mounting screws
4. Place the main module and screw the two screws referring to steps 11 and 12 of 'Mounting the device.'

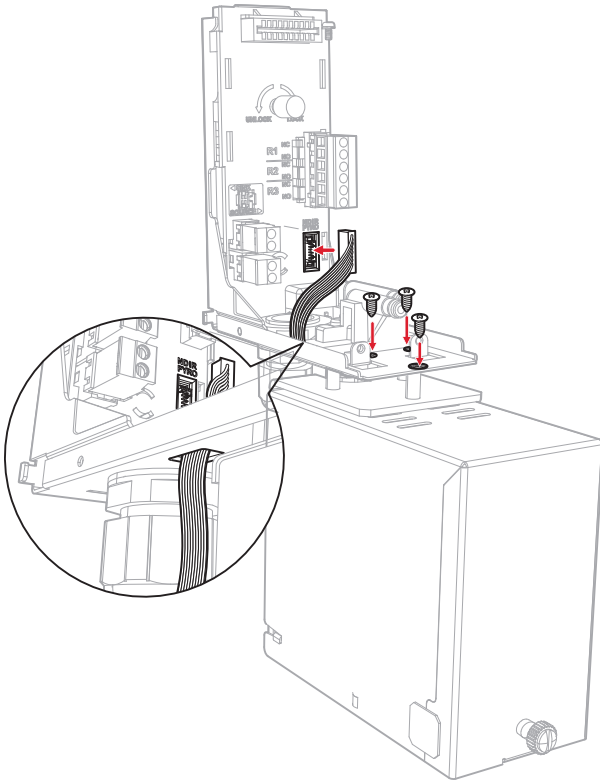

## Install the sensor cartridge

1. Turn the power off.
2. Verify that the part number and type of sensor cartridge are correct for your application, then remove the sensor cartridge from the packaging. Remove the BiAS battery module and plug caps from the sensor cartridge if needed.
3. Push the **sensor cartridge** gently until fully seated.

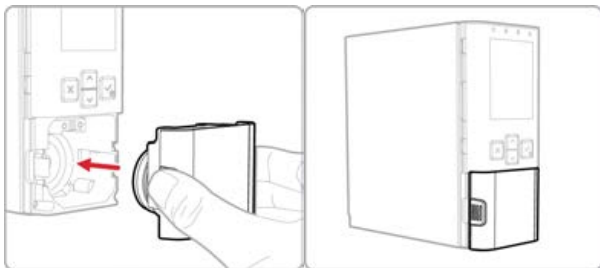

4. Confirm the display for gas type and concentration on the screen.

NOTE: All sensor cartridges are supplied calibrated. Some sensor cartridges can monitor for more than one type of gas. Please refer to the User Manual for details about settings and replacement.

## Turn the device on & off



## Line Integrity Test

Honeywell offers the optional capability to check for leaks in Midas S2 sample lines. Midas S2 Transmitter for LIT (line Integrity Test) detects any leak in the tubing with a pneumatic signal change from the valves installed at the end of the sample line. This test is performed automatically as a LIT. The Line Integrity Test Option requires the Calibration process.



### **CAUTION RISK OF MALFUNCTION**

- If you make any changes to the Pump Module, Check Valve, Filter, and Tube, and start a new LIT calibration again.
- Verify the Check Valve flow direction during installation.
- Verify both the Check Valve and Tube are firmly assembled.
- Mark the insertion from the end of the tube to the length of 15.5mm. When inserting the tube, make sure the insertion is up to the marked position.
- The external filter is installed further from the Transmitter, and the Check Valve is installed closer to the transmitter.

## Install and leak check

1. Mount the Midas S2 using the integral mounting bracket.
2. Connect the actual inlet & outlet tubes to Midas S2 and turn on the system.

Verify the Check-Valve is attached to the Sampled Point.  
After the Power ON, wait approximately 10 minutes for pump stabilization and corrective measures.

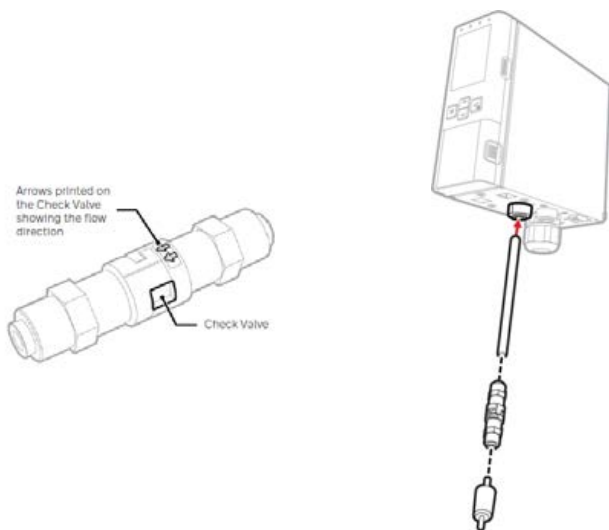

3. Perform a Block test to ensure internal connections are secure. Refer to Block test in the *Midas S2 User Manual* for further information.

## Operation

Select **MENU > TEST MODE > LIT** and follow the instructions for **LIT enable, Setting, Calibration, and Manual test**.

Please secure the calibration procedure for the accurate operation of LIT.

## Maintenance and replacement

Please refer to the User Manual for details about the pump, sensor cartridge, and other replacements.

## Contact Us

### Europe, Middle East, Africa

Life Safety Distribution GmbH

Javastrasse 2

8604 Hegnau

Switzerland

Tel: +41 (0)44 943 4300

gasdetection@honeywell.com

### Customer service:

Tel: 00800 333 222 44 (Freephone number.)

Tel: +41 (0)44 943 4380 (Alternative number)

Middle East Tel: +971 4 450 5800 (Fixed Gas Detection)

Middle East Tel: +971 4 450 5852 (Portable Gas Detection)

### Americas

Honeywell Analytics Distribution Inc.

405 Barclay Blvd.

Lincolnshire, IL 60069. USA

Tel: +1 847 955 8200

Toll-free: +1 800 538 0363

detectgas@honeywell.com

RAE Systems by Honeywell

Phone: 408.952.8200

Toll-Free: 1.888.723.4800

## **Asia Pacific**

Honeywell Co., Ltd.

5F SangAm IT Tower

434, World Cup buk-ro, Mapo-gu

Seoul 03922 , Republic of Korea

Tel : +82(0) 2 6909 0300

India Tel: +91 124 4752700

China Tel: +86 10 5885 8788 3000

analytics.ap@honeywell.com

## **Technical Support**

EMEA: gastechsupportemea@honeywell.com

Americas: is.gas.techsupport@honeywell.com

AP: gas.techsupport.apaci@honeywell.com

LATAM: SoporteTecnico.HGAS@Honeywell.com

Brazil: SuporteTecnico.HGAS@Honeywell.com

Midas® S2

Quick Reference Guide  
3023M5000

Language: English

Revision A

© 2023

Thursday, March 30, 2023

CoE CDMX

Manuals and other information about this product are available  
at : [sps.honeywell.com](https://sps.honeywell.com)

