



3170 Wasson Road • Cincinnati, OH 45209 USA  
 Phone 513-533-5600 • Fax 513-871-0105  
 steriflow@richardsind.com • www.steriflowvalve.com

## I & M Mark 978LF Series

### Installation & Maintenance Instructions for Mark 978 Low Flow Sanitary Control Valve

#### Please read these instructions carefully!

Your Steriflow product will provide you with long, trouble-free service if it is correctly installed and maintained. Spending a few minutes now reading these instructions can save hours of trouble and downtime later. When making repairs, use only genuine Steriflow Valve parts, available for immediate shipment from the factory.

#### Ideal Installation

1. The MK978LF valve is designed for sanitary service and should be installed in a clean system. As such, strainers at the valve inlet to protect the valve should not be necessary.
2. For **angle body valves**, the valve is normally installed with inlet vertical on the bottom, and outlet horizontal to provide the best drainage inside the valve. This is recommended only for drainage considerations: the valve will function in any position. For optional **INLINE Series valves**, the valve must be installed on horizontal pipe in an upright position with the top plane of the actuator parallel to the floor.
3. Steam control valves are best located at a high point in the piping system with the take-off out of the top of the steam header. This minimizes the possibility of water in the valve.
4. For best control, 3'0" straight sections of pipe should be installed on either side of the valve.
5. Use caution in tightening commercial sanitary fittings. Over-tightening can cause the gasket to extrude into the flow passage.
6. If possible, install a relief valve downstream from the MK978LF. Set at about 15% above the control pressure.
7. In gas or vapor service, select outlet piping at least one pipe size larger than the inlet.
8. Operate the MK978LF within pressure/temperature ratings on the nameplate. Refer to catalog for additional details.
9. Provide proper air pressure to actuator. Valves with positioners: 20 psig supply for 3-15 range, 40 psig supply for 6-30 range; valves without positioners: 40 psig supply to controller.

#### Start-Up

1. Make sure actions of control valve and controller are such as to give desired results as shown in the following table. To change the action, see instructions under **Actuator Subassembly**.

Controller Action		
If increase in pressure or temperature must:	And the action of the valve is:	Then the action of the controller must be:
Close Valve	Air-to-Close	Direct
	Air-to-Open	Reverse
Open Valve	Air-to-Close	Reverse
	Air-to-Open	Direct

The Mark 978LF has been pre-set at the factory. However, finer adjustments may be required to compensate for pressure drop conditions of the application.

2. With the inlet, outlet, and bypass shutoff valves closed, and no pressure in the downstream line, fully open the outlet shutoff valve. Slowly open the inlet valve just enough to start flow through the MK978LF. Increase flow gradually by slowly opening the inlet shutoff valve. Do not fully open the inlet valve until you are sure that the controller and control valve have control of the system. Usually, the handwheel on the inlet valve will turn freely once this point is reached.
3. To shutoff the line fluid, close the inlet shutoff valve first, followed by the outlet shutoff valve.

#### Preparing for Maintenance

**Warning: be sure that there is not pressure in the valve before loosening any fitting or joint.**

1. Close inlet shutoff valve and bypass valve.
2. Open the MK978LF.
3. Allow pressure to bleed off downstream.
4. When pressure gauge shows there is no pressure in the valve, close outlet shutoff valve.
5. When lubricant is needed, use one that is compatible with both your process and the valve's seal material (see nameplate). Jordan uses, and recommends, Bostic NEVER-SEEZ, white food grade with PTFE, catalog #NSWT-14 (improved version without mineral oils). Refer to appropriate drawings when performing maintenance.

#### Seal Replacement

The MK978LF is supplied with two different seals: an o-ring to seal the stem and a gasket to seal the body to bonnet joint.

## Body / Bonnet Gasket Replacement

1. The Mark 978LF must be in open position, plug (3) off seat. For reverse acting valves, apply pressure to actuator to lift plug off seat.
2. Remove bonnet bolts (29) and separate body (1) from bonnet (4).
3. Remove the old gasket (28). Lubricate sealing surface in body, install new gasket, and reassemble.

Note: For normally closed valves, retract stem with air pressure in actuator to reassemble easily.

## Stem O-Ring

1. MK978LF must be in open position, plug (3) off seat. Reverse acting valves need pressure applied to actuator to lift plug off seat. Actuator can be removed by removing nuts, for more working clearance.
2. Remove bonnet bolts (29) and separate body (1) from bonnet (4).
3. Remove air pressure from actuator.
4. Loosen the jam nuts (30), mark the point on the stem (3) where it meets the actuator stem (23), then remove stem nuts (30) and travel indicator (31), and unscrew the stem from the actuator stem. Pull the stem/plug (3) downward and out of the bonnet.
5. Remove the bushing lock ring (8), stem bushing (7), and o-ring (32) using a hooked removal tool.
6. Lubricate and install new o-ring (32) in the bonnet (4). Replace the plug (3) by inserting it through the bottom of the bonnet (4).
7. Reinstall the stem bushing (7) and replace the bushing lock ring (8).

---

## Actuator

---

### Actuator Disassembly – Reverse Acting

1. Apply sufficient air pressure to lift plug (3) off seat. Separate body and bonnet.
2. Loosen and remove actuator mounting nuts (27).
3. Loosen the jam nuts (30), mark the point on the stem (3) where it meets the actuator stem (23), then unscrew the stem from the actuator stem. Remove stem nuts (30) and travel indicator (31) from valve stem (3). Pull the plug (3) downward and out of the bonnet.
4. Remove air pressure from actuator.
5. Remove housing bolts (22) then separate upper and lower housings (21 & 9).
6. Remove springs (14).
7. Hold actuator stem (23) with a wrench on the flats on its lower end and remove the cap screw (20).
8. Remove in order: lockwasher (35), diaphragm plate (13), diaphragm (17), diaphragm washer (19), thread seal (24), and spacer (25).
9. Remove upper and lower retaining rings (15), actua-

tor stem (23), upper and lower back-up rings (18) and o-ring (16).

### Actuator Disassembly – Direct Acting

1. Loosen and remove the actuator support leg bolts (27).
2. Loosen the jam nuts (30), mark the point on the stem (3) where it meets the actuator stem (23), then unscrew the stem from the actuator stem. Remove stem nuts (30) and travel indicator (31) from valve stem. Pull the stem/plug (3) downward and out of the bonnet.
3. Remove housing bolts (22) and separate upper and lower housings (21 & 9).
4. Hold actuator stem (23) with a wrench on the flats on its lower end and remove cap screw (20).
5. Remove in order: lockwasher (35), spacer (25), diaphragm washer (19), diaphragm (17), diaphragm plate (13), thread seal (24), and springs (14).
6. Remove upper and lower retaining rings (15), actuator stem (23), upper and lower back-up rings (18), and o-ring (16).

---

## Actuator Subassembly

---

All actuators have field reversible action. To reverse the action, follow reassembly procedure for desired action.

### Reverse Acting

1. Lightly grease and install o-ring (16) and upper and lower back-up rings (18) in lower case (9). Insert actuator stem (23) with the wrench flats outside the lower case, and install upper and lower retaining rings (15).
2. Place spacer (25) with thread seal on the actuator stem with thread seal (24) facing the actuator stem and o-ring gland.
3. Assemble the diaphragm washer (19), diaphragm (17), diaphragm plate (13), spacer (35) and bolt (20).
4. Tighten actuator stem bolt (20) and align bolt holes in the diaphragm with holes in lower actuator case.
5. Replace springs (14) over bosses in diaphragm plate (13).
6. Reinstall actuator bolts (22) and tighten.

### Direct Acting

1. Lightly grease and install o-ring (16) and back-up rings (18) into lower case (9).
2. Assemble actuator stem (23), seal washer with thread seal (24) toward diaphragm plate (13), diaphragm (17), diaphragm washer (19), and spacer (25) with the actuator bolt (20) and tighten.
3. Hold cap screw by its head in vise, actuator stem pointing up. Install upper retaining ring (15).
4. Install springs (14) over dimples in diaphragm plate (13).

5. Taking care not to cut o-ring, insert actuator stem (23) through the lower case (9) so the wrench flats are outside the actuator case. Install lower retaining ring (15).
  6. Place the upper actuator case (21) on the diaphragm (17) in alignment with the bolt holes.
  7. Place four bolts (22) 90° apart and tighten finger tight. Install remaining bolts and nuts evenly while alternating across the actuator case.
- Hard seated valves may not be capable of tight shutoff (leakage would cause downstream pressure to rise).
  - Overranging the valve – use smaller Cv.

---

## Troubleshooting

---

### **If You Experience Erratic Control:**

- Oversizing can cause cycling or hunting – *recalculate required Cv*.
- Undersizing can cause the control point to drop off under peak loads – *increase trim size*.
- Inlet pressure may be varying significantly and the controller may not be following it – *adjust controller*.
- Improper trim characteristic.
- Steam traps may need reconditioning.
- Safety relief valves may be leaking.
- Valve stroke may be out of adjustment or there may be foreign matter in the valve preventing full plug movement.

### **If You Experience Insufficient Flow:**

- Check shutoff valves to be sure they are fully open.
- Inlet pressure to the valve may be insufficient to provide the needed flow – *check the inlet pressure with a pressure gauge*.
- Steam traps may need reconditioning.
- Foreign material in the trim may prevent the valve from passing its full capacity.
- Diaphragm failure, insufficient air pressure, or incorrect actuator spring adjustment in reverse acting (air to open) actuators will prevent the valve from properly opening.

### **If You Experience Overpressure (Outlet):**

- Foreign material in the trim can prevent the valve from shutting off.
- Diaphragm failure, insufficient air pressure, or incorrect actuator spring adjustment in direction acting (air to close) actuators will prevent the valve from properly stroking closed.
- Hard seated valves may not be capable of tight shutoff (leakage would cause downstream pressure to rise).
- Overranging the valve – use smaller Cv.

### **If You Experience Leakage:**

- Excessive pressure drop across the valve could prevent the valve from shutting off properly – check the catalog ratings for the maximum allowable pressure drop for your trim, action and actuator.

## Illustration and Parts List

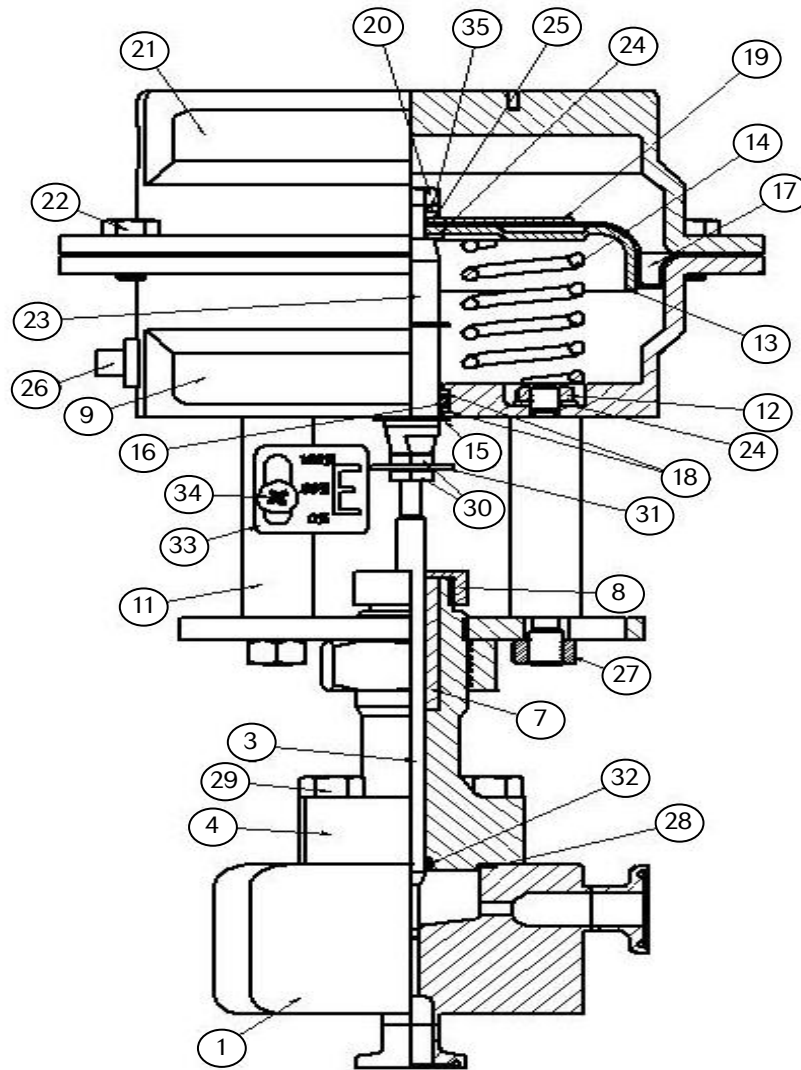

Item	Description	Qty.	Item	Description	Qty.	Item	Description	Qty.
1	Body	1	16	O-Ring	1	27	Nut	2
*3	Plug	1	17	Diaphragm	1	*28	Gasket	1
4	Bonnet	1	18	Back-Up Ring	1	29	HHCS	4
*7	Bushing	1	19	Diaphragm Washer	1	30	Nut	2
8	Lock Ring, Bushing	1	20	HHCS	1	31	Indicator Washer	1
9	Lower Actuator Case	1	21	Upper Actuator Case	1	*32	O-Ring	1
11	Support Leg	2	22	HHCS	6	33	Travel Scale	1
12	Jam Nut	2	23	Actuator Stem	1	34	RHMS	1
13	Diaphragm Plate	1	24	Thread Seal	3	35	Lockwasher	1
14	Spring	3	25	Spacer	1	36	Nameplate (not shown)	1
15	Retaining Ring	2	26	Actuator Vent	1	37	Drive Screw (not shown)	2
*	Recommended Spare Parts							