



3170 Wasson Road • Cincinnati, OH 45209 USA
Phone 513-533-5600 • Fax 513-871-0105
marwin@richardsind.com • www.marwinvalve.com

I & M 5801/6801 Series

Installation & Maintenance Instructions for Marwin 5801/6801 Series Floating Ball Valves

Warning: Marwin Valve Ball Valves must only be used, installed and repaired in accordance with these Installation & Maintenance Instructions. Observe all applicable public and company codes and regulations. In the event of leakage or other malfunction, call a qualified service person; continued operation may cause system failure or a general hazard.

Please read these instructions carefully!

Your Marwin Valve product will provide you with long, trouble-free service if it is correctly installed and maintained. Spending a few minutes now reading these instructions can save hours of trouble and downtime later. When making repairs, use only genuine Marwin Valve parts, available for immediate shipment from the factory.

Scope

This manual is intended as a guide to assist customers in the storage, installation, and maintenance of Marwin 5801 and 6801 Series Ball Valves. Subsequent additions or special instructions will be provided for special ball valves, critical service, or customer requirements.

Applicability



This manual is applicable to the following Marwin ball valves: 1/2" - 8" 5801F, 1/2" - 8" 6801F, and 1" - 8" 5801R. Valve identification is given on a nameplate attached to the pipe flange outside diameter.

Caution

1. Valve pressure ratings are based on many variables, including valve series and size, as well as body, seat and bolt material. Verify that application does not exceed the pressure or temperature rating on the nameplate.
2. **ALWAYS** depressurize the line with the valve in the

OPEN position before disassembly.

3. Wear protective equipment and take appropriate precautions to safeguard against injury caused by the discharge of trapped fluids.
4. Use only Marwin recommended spare parts for maintenance.
5. To ensure safety and maintain warranty, never modify valve in any way without prior approval from Marwin.

Storage

Silicone free oil is used as lubrication on all internal surfaces. This may be removed with a solvent if found objectionable. All valves are adequately packed in a strong cardboard case in such a way as to avoid any possible damage during transport and storage.

CAUTION: If ball valves are not destined for immediate use, the following precautions should be taken:

1. If possible, leave the ball valves in their packing cases during the period of storage.
2. Ball valves must remain in open position during this time.
3. In order to prevent damage, protective plastic covers on valve ends should not be removed until immediately prior to installation.
4. It is advisable to store the valves in waterproof conditions. Ball valves should be protected to safeguard against humidity, moisture, dust, dirt, sand, mud, salt spray, and seawater.
5. All valves complete with actuators are to be stored in dry conditions.
6. Valves to be stored for a long period of time should be checked by the quality control personnel every six months; every three months when valves are automated.

Maintenance During Storage Period

- Internal surface should be inspected to check for dust or other foreign objects.
- Rust or dust must be removed by cleaning with proper solvent.
- After cleaning, ball valves must be lubricated with

- an adequate lubricant.
- Ball valves should be operated for at least two complete cycles before installing or returning to storage.

Installation

The ball valves may be installed in any position using standard pipe fitting practice.

Caution: Before installation of the valve:

1. Pipe must be free of tension both during and after installation.
2. Pipe must be flushed to clean dirt, welding residues, etc. which would damage ball or seats.
3. The valve should be kept in OPEN POSITION during installation and protective plastic covers must be removed only at the moment of installation.
4. Before shipment, the ball is lubricated with a silicone free oil. This can be easily removed with an application compatible solvent if required.
5. If the valve was specified to be tested per ASME B16.34, there may be some trapped water between the ball and the body cavity. This can be removed by partially opening the valve, thereby exposing the cavity to the through port of the ball.
6. Special care should always be taken when installing automated ball valves that the ball is in the proper position.

Installation of Flanged Ends

1. Verify valve is in the full open position.
2. For valves with upstream vented ball, including valves with API 6D option, install valves in accordance with directional arrow on body (vent on closed ball upstream).
3. Use the appropriate size bolt and heavy hex nut (not included) as recommended for flange size and class.
4. Flange connection requires gasket (not included).
5. Follow gasket manufacturer's recommended practice for tightening flange bolts.

Manual Operation

1. Open and close the valve by turning the handle 1/4 turn (90°).
2. Valve is in open position when handle is in line with the pipe.
3. Valve is in closed position when the handle is perpendicular to the pipe.

Maintenance

Before starting maintenance, please read information contained in the **Caution Section** of the manual.

1. Open and close the ball valve at least once to release the pressure completely from valve body.
2. Ball valves, if correctly used, normally do not need any internal lubrication and maintenance. However, when necessary, ball or seats can be replaced by qualified personnel following the instructions of this manual.
3. For further information, please refer to **SPARE PARTS LIST Section**.

Valve Disassembly

A. To Inspect and / or Replace Body Seals, Seats, Packing & Ball

Reference exploded view for part identification.

1. Valve must be in the open position.
2. Remove valve from line.
3. Remove bolt (17), and washer (16), loosen screw (22), and handle (12A), or T-handle (12B) and T-handle coupler (12C).
4. Remove snap ring (13), turn ball until half open, and remove stop plate (11).
5. Remove gland bolts (10B) and gland flange (10A).
6. Loosen / remove body bolt nuts (20), and lift end cap (2) off. Be careful that ball (4) does not fall out of body.
7. Remove body seal (6) from body and seat (3) from end cap.
8. If necessary, remove body studs (14B) from body.
9. Close ball and remove ball (4) and seat (3) from body.
10. Remove stem (5) by pushing down into body. (Do not remove anti-static pin (18) or spring (19)).
11. Remove thrust washer (7) from stem shoulder or body recess, and packing (8) from body.

B. Inspection and Replacement

With the valve completely disassembled, clean and examine all components:

1. Ball - The surface of the ball should be free from any defect. If any are found, the ball should be replaced. Using a defective ball will be extremely detrimental to valve performance.
2. Seats - Replacement of seats is recommended.
3. Stem seals and body seals - Should be discarded and replaced.
4. Remaining components of the valves - After cleaning, carefully examine for wear, corrosion, and mechanical damage. Replace all defective parts.

- Clean inside of body and stem housing. Light grease, compatible with line fluid, can be used on ball, seals and stem surfaces.

NOTE: A spare parts list is available for this valve. See exploded view on back page for repair parts identification. Please specify specific valve number to ensure proper parts are ordered. Marwin Valve does not take responsibility for incorrectly ordered spare parts.

Re-Assembly

- Place thrust washer (7) on stem shoulder (5), and insert stem from inside body (1).
- Install packing (8) and seat (3) in body (1).
- With ball (4) in closed position, install in body (1). (Ball must be in closed position so groove in ball aligns with bottom of stem.)
- If they were removed, install body studs (14B) in body (1).
- Install body seals (6) in body (1) and seat (3) in end cap (2).
- Place end cap (2) - seat (3) assembly on body (1).
- Install body bolts nuts (20) on body studs (10B), and gradually tighten, using an alternating tightening pattern.
- Install gland flange (10A) and gland bolts (10B) in body (1).
- Install stop plate (11) in original position over stem (5), then install snap ring (13) on stem.
- Install handle (12A) or T-handle coupler (12C), install and tighten screw (22) and bolt (17).

Testing

- After completing the reassembly, check that the valve operates smoothly by opening and closing valve several times.
- If entire valve was removed from line and if facilities are available, test the ball valve to appropriate specifications.

Troubleshooting

- Stem Leakage:** Stem leakage in the stem packing area may be eliminated by increasing the torque on the stem nut (14) in 1/4 turn increments. If leakage persists, replace stem packing (9).
- Body Seal Leakage:** Check the torque of the body bolts (11). Replace body seal (15) if leakage persists.
- In Line or Seats Leakage:** Check to be sure valve is in fully closed position. If leakage persists, the valve must be disassembled and damaged parts replaced.

Torque Data

Series 5801F					
Size	Series	Body Bolt		Gland Bolt	
		Size	Torque	Size	Torque
			in.-lbs.		in.-lbs.
1/2"	5801F	5/16-18 UNC	191	1/4-20 UNC	18
3/4"		5/16-18 UNC	191	1/4-20 UNC	18
1"		3/8-16 UNC	348	5/16-18 UNC	35
1-1/4"		3/8-16 UNC	348	5/16-18 UNC	35
1-1/2"		7/16-14 UNC	391	3/8-16 UNC	87
2"		7/16-14 UNC	391	3/8-16 UNC	87
2-1/2"		7/16-14 UNC	391	3/8-16 UNC	87
3"		1/2-13 UNC	651	W1/2-12	174
4"		1/2-13 UNC	651	5/8-11 UNC	174
6"		5/8-11 UNC	1606	5/8-11 UNC	261
8"	3/4-10 UNC	3038	5/8-11 UNC	261	

Series 5801R					
Size	Series	Body Bolt		Gland Bolt	
		Size	Torque	Size	Torque
			in.-lbs.		in.-lbs.
1"	5801R	5/16-18 UNC	191	1/4-20 UNC	18
1-1/2"		3/8-16 UNC	343	5/16-18 UNC	35
2"		7/16-14 UNC	391	3/8-16 UNC	87
3"		1/2-13 UNC	651	W1/2-12	174
4"		1/2-13 UNC	651	W1/2-12	174
6"		1/2-13 UNC	750	5/8-11 UNC	261
8"		5/8-11 UNC	1606	5/8-11 UNC	261

Series 6801F					
Size	Series	Body Bolt		Gland Bolt	
		Size	Torque	Size	Torque
			in.-lbs.		in.-lbs.
1/2"	6801F	5/16-18 UNC	191	1/4-20 UNC	18
3/4"		5/16-18 UNC	191	1/4-20 UNC	18
1"		3/8-16 UNC	348	5/16-18 UNC	35
1-1/2"		7/16-14 UNC	391	3/8-16 UNC	87
2"		7/16-14 UNC	391	3/8-16 UNC	87
3"		1/2-13 UNC	651	W1/2-12	174
4"		5/8-11 UNC	1606	5/8-11 UNC	261
6"		3/4-10 UNC	3038	5/8-11 UNC	261
8"		7/8-9 UNC	3039	5/8-11 UNC	261

W1/2-12 is 1/2" British standard Whitworth coarse series bolt.

Exploded View

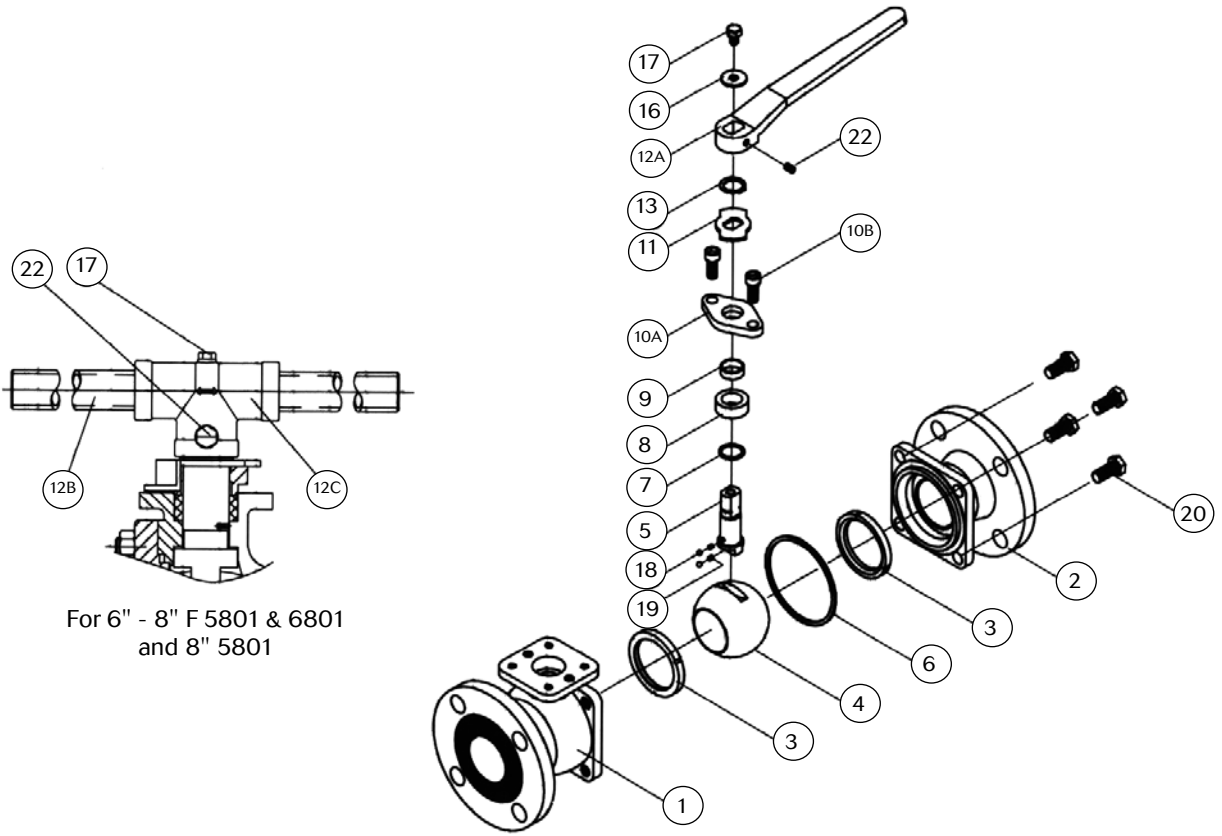

For 6" - 8" F 5801 & 6801
and 8" 5801

Item	Description	Item	Description
1	Body	12B	Pipe T-Handle (for 6" - 8")
2	End Cap	12C	Coupler T-Handle (for 6" - 8")
3*	Seat	13*	Snap Ring
4	Ball	14A	Body Bolt (for 1/2" - 4")
5	Stem	14B	Stud, Body (for 6" - 8")
6*	Body Seal	15	Gland Bolt
7*	Thrust Washer	16	Flat Washer
8*	Packing	17	Bolt Handle
9*	Gland Bushing	18	Static Pin
10A	Gland Flange	19	Static Spring
10B	Gland Bolt	20	Nut Body (for 6" - 8")
11	Stop Plate	21	Tag (not shown)
12A	Handle (for 1/2" - 4")	22	Screw, Handle

* Recommended Spare Parts

Spare Parts Kit		
Item	Qty.	Description
3	2	Seats
6	1	Body Seal
7	1	Thrust Washer
8	1 set	Packing
9	1	Gland Bushing
13	1	Snap Ring