



JORDAN VALVE

3170 Wasson Road • Cincinnati, OH 45209 USA
Phone 513-533-5600 • Fax 513-871-0105
info@richardsind.com • www.jordanvalve.com

I & M Mark 80 Supplement

Field Replacement of SWA Actuator and Range Changes

Warning: Jordan Valve Control Valves must only be used, installed and repaired in accordance with these Installation & Maintenance Instructions. Observe all applicable public and company codes and regulations. In the event of leakage or other malfunction, call a qualified service person; continued operation may cause system failure or a general hazard. Before servicing any valve, disconnect, shut off, or bypass all pressurized fluid. Before disassembling a valve, be sure to release all spring tension.

Please read these instructions carefully!

Your Jordan Valve product will provide you with long, trouble-free service if it is correctly installed and maintained. Spending a few minutes now reading these instructions can save hours of trouble and downtime later. When making repairs, use only genuine Jordan Valve parts, available for immediate shipment from the factory.

Thermal System Replacement

To replace the thermal system (actuator), the following steps should be followed:

1. If you are only replacing the actuator and not changing the range of the valve, make a mark on the yoke with a grease pencil where the spring washer (6Y) is so that you can return to the approximate set point when the replacement is complete.
2. Remove all spring tension on the valve range spring (2S) by turning the adjusting wheel (5Y) to its lowest position.
3. Remove the four actuator screws (7Y) from the yoke and remove the actuator assembly (1A) from the yoke.
4. Position the new actuator assembly (1A) on the yoke so that the screw holes in the adapter plate (4A) line up with the four screw holes in the yoke.

Note: the actuator assembly will be raised up off of the yoke surface approximately 1/8" if the ambient temperature is above the low end of the range of the actuator assembly.

5. In order to install the actuator assembly to the yoke, use the two temporary 10-32UNFx 3/4" long screws (supplied with the replacement actuator, these will have the red head) in order to engage the threads of the adaptor mounting plate.
6. Install the two 3/4" long temporary screws 180° apart and draw the actuator down in order to engage the 5/8" long standard screws in the other two holes. Once the standard actuator screws are engaged, draw the actuator down tight and then

remove the temporary screws, replacing them with the other two standard screws. (*Caution: don't tighten down the longer screw any more than necessary to engage the standard screw. This could cause damage to the sealed unit if the screws are threaded in too far.*) Discard the temporary screws and tighten all four standard screws.

7. Adjust the range spring by turning the adjusting wheel (5Y) so that the spring washer (6Y) is at the mark you made on the yoke before starting the actuator replacement. This will get you close to the required set point of the valve. Finer adjustments will be needed to get the exact setting required by the system. See Installation & Maintenance Instructions for MK 80 for details.

Range Change

Some range changes, especially the light spring ranges, may require you to change the range spring. The following steps should be followed when changing the range spring:

1. Follow steps 2 and 3 under Thermal System Replacement to remove the Thermal system (actuator assembly 1A).
2. Remove the stem connector assembly by loosening nut (11Y) and removing the bolt (12Y) and stem connector halves (10Y). Lift the actuator stem and stroke stop assembly (2A & 9Y) out of the top of the yoke. *Caution: DO NOT move the valve stem or the seats will need to be readjusted.*
3. Remove the range spring (2S) through the top of the yoke and replace it with the new range spring. Replace the stem connector, again taking care not to move the valve stem.
4. Follow steps 4, 5 & 6 to complete the actuator installation.
5. Adjust the range spring (2S) in order to give you the proper setting. See Installation & Maintenance Instructions for MK 80 for details.

Illustration and Parts List

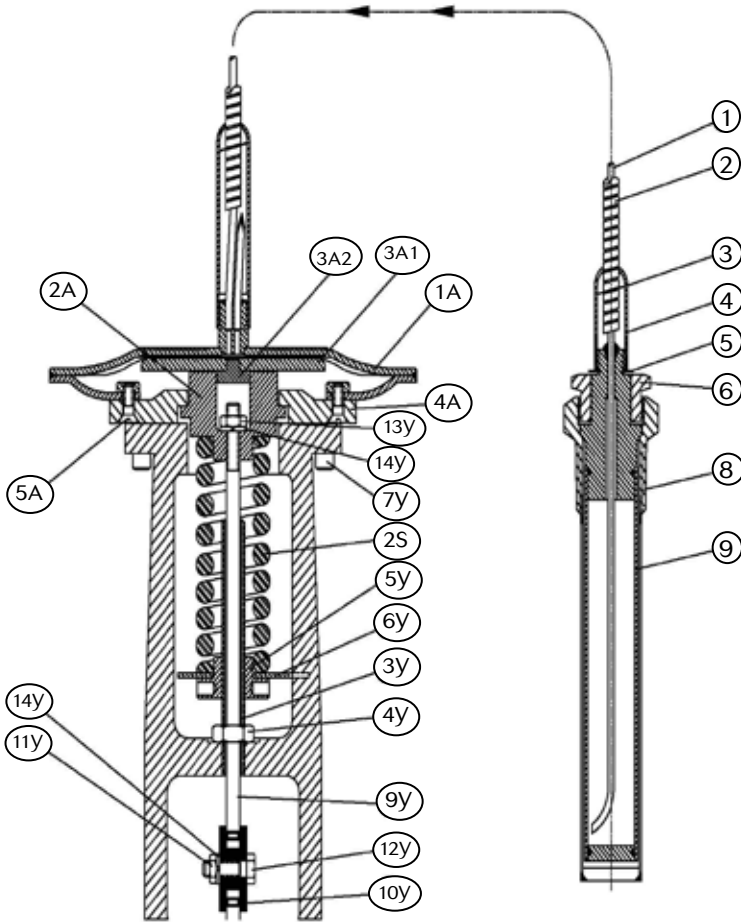

Item	Description
2S	Spring
1Y	Yoke
2Y	Yoke Screw
3Y	Adjusting Post
4Y	Jam Nut
5Y	Adjusting Wheel
6Y	Spring Washer
7Y	Actuator Screw
9Y	Actuator Stem
10Y	Stem Connector
11Y	Stem Connector Nut
12Y	Stem Connector Bolt
13Y	Stroke Stop Nut
14Y	Lockwasher
1A	Actuator Assembly
2A	Stroke Stop
3A1	Diaphragm Plate
3A2	Diaphragm Plate Plug
4A	Adaptor Mounting Plate
5A	Mounting Plate Screw
1	Capillary
2	Armor
3	Retaining Ring
4	Short Adaptor
5	Retaining Ring
6	Bulb Nut
8	Tank Fitting
9	Bulb Assembly

Ordering Spare Parts

Use only genuine Jordan Valve parts to keep your valve in good working order. So that we can supply the parts, which were designed for your valve, we must know exactly which product you are using. The only guarantee to getting the correct replacement parts is to provide your Jordan Representative with the valve serial number. This number is located on the valve identification tag. If the serial number is not available, the parts needed for your valve might be determined using the following information: Model Number, Valve Body Size, Seat Material and Cv Rating, Spring Range and Set Point, Trim Material, Part Name - Number and Quantity.

NOTE: Any parts ordered without a valve serial number that are found to be incorrect are subject to up to a minimum 25% restock charge when returned.