



3170 Wasson Road • Cincinnati, OH 45209 USA
Phone 513-533-5600 • Fax 513-871-0105
info@richardsind.com • www.jordanvalve.com

Mark 688 Series

Installation Instructions for Mark 688 Piloted Soft Seat Regulators

Warning: Jordan Valve Pressure Regulators must only be used, installed and repaired in accordance with these Installation & Maintenance Instructions. Observe all applicable public and company codes and regulations. In the event of leakage or other malfunction, call a qualified service person; continued operation may cause system failure or a general hazard. Before servicing any valve, disconnect, shut off, or bypass all pressurized fluid. Before disassembling a valve, be sure to release all spring tension.

Please read these instructions carefully!

Your Jordan Valve product will provide you with long, trouble-free service if it is correctly installed and maintained. Spending a few minutes now reading these instructions can save hours of trouble and downtime later. When making repairs, use only genuine Jordan Valve parts, available for immediate shipment from the factory.

Ideal Installation

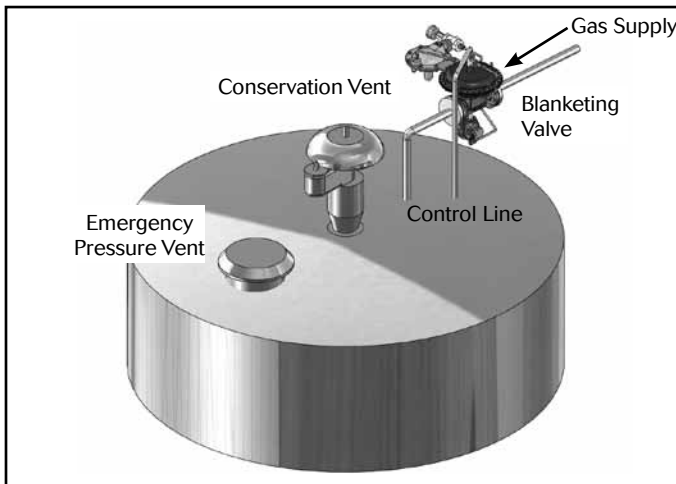

1. To protect the valve from grit, scale, thread chips and other foreign matter, ALL pipelines and piping components should be blown out and thoroughly cleaned before the installation process begins.
2. Shutoff valves, pressure gauges and by-pass piping are optional, and if installed should be in accordance with all applicable codes, standards, and practices. They are recommended to provide easier adjustment, operation, and testing.
3. The flow arrow on the valve body must be pointed in the direction of flow. Ideally, the valve should be installed in the highest horizontal line of piping.
4. If possible, install a relief valve downstream from the valve. Set at slightly above the control point of the valve but below the maximum safety limit for the tank.
5. It is strongly recommended that the installer read

and be thoroughly familiar with API 2000, Standard Information for Tank Blanketing Regulator Selection before installing and attempting to operate this product.

Control Line

A control line must be installed as follows:

1. Connect one end of a 3/4" pipe to the fitting on top of the main valve actuator.
2. Connect the other end to an appropriate fitting on the tank.
3. DO NOT locate the control line tap in any location where turbulence or abnormal velocities may occur.

Control line should slope downward toward the tank to prevent Condensation buildup.

1. Make the control line as short and straight as possible.
2. Connect the control line to the point where the pressure is to be controlled.
3. Increase 1 pipe size for every 10 feet of control line, with setpoints less than 5" w.c. (0,012 bar).

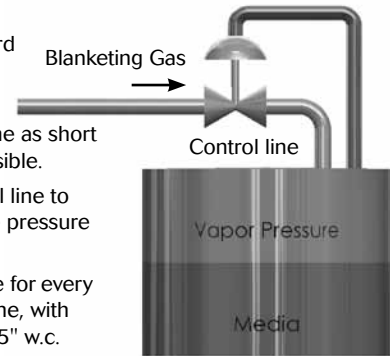

4. The control line should be sloped away from the valve.
5. Install a pressure gauge to measure pressure in the tank itself, not in the outlet piping or the control line to aid in setting the valve.

Control Line Piping Recommendation

- Keep the regulator as close to the tank as possible and as high as possible.
- Minimize the length of the downstream pipe coming from the valve.

- NEVER reduce the pipe size on the valve outlet to the tank. This line must always be as large as the valve size, or one pipe size larger to assure it does not act as a restriction.
- Any downstream isolation valve after the regulator must be a full port type. The isolation valve cannot act as a restriction.
- The sensing line must be a minimum of 3/4" pipe.
- A sensing line isolation valve is recommended. Again, must be full ported.
- Slope the sensing line to the sensing port on the tank.
- Keep the sensing line as short and straight as possible.
- For each 10 feet of sensing line, increase the line size by one pipe diameter. (Especially important on the blanket pressures of less than 5 inches of water column).
- Keep the sensing port on the tank as far removed as possible from the downstream pipe outlet going into the tank.

Start-Up

With the inlet, outlet, and bypass shutoff valves closed, and no pressure in the downstream line:

1. Slowly open the inlet valve just enough to start flow through the valve. Observe the tank pressure gauge. Increase the downstream pressure slowly by gradually opening the inlet valve.
2. Do not fully open the inlet valve until you are sure that the regulator has control of the system. Usually, the handwheel on the inlet valve will turn freely when this is achieved.
3. To change the controlled pressure, adjust the controlled pressure supplied to the top of the diaphragm.

Trouble Shooting

The first step in troubleshooting a piloted pressure regulator is to classify the action of the controlled pressure into one of the following categories:

- A. Under Pressure: Controlled pressure too low; not enough flow or no flow through valve.
- B. Over Pressure: Valve will not close or controlled pressure increases after valve closes.
- C. Pressure Fluctuates: Controlled pressure rises and falls, will not settle out under low loads.

The next step is to determine what could cause the trouble. The third step is to locate and remedy the cause by the process of elimination. Make no assumptions and check the easy ones first. The guide below lists the controlled pressure action, common causes and procedure for checking each cause.

Controlled pressure action UNDER PRESSURE:

- Valve undersized for application. Check capacity required and valve capacity.
- Line strainer screen clogged. Blow down strainers or visually check that they are clear.
- Incorrect setting on range spring. Vary the setting and check response.
- Main valve diaphragm or balance diaphragm ruptured. See action on valve maintenance.
- Malfunction of other piping components. Check for leaking safety valves, inadvertently opened or closed valves.

Controlled pressure action OVER PRESSURE:

- Incorrect setting on range spring. Vary the setting and check response.
- Main valve seats leaking. Close inlet shut-off valve, allow downstream pressure to bleed off, close outlet valve and remove loading pressure tubing. Back out adjusting screw on valve until free. Crack open inlet shut-off valve - if the fluid issues from the main valve port, the main valve seats are leaking.
- By-pass shut-off leaking. During period of leakage close outlet shut-off valve, observe downstream pressure gauge.

Controlled Pressure Fluctuates:

- Valve oversized. Check capacity required and valve capacity.

Main Valve

Note: All work to the main valve can be accomplished in-line. The only reason to remove the valve is if the location makes it too difficult to work on the regulator.

Main Valve Diaphragm

1. Remove pilot valve tubing.
2. Remove the control line to the upper case.
3. Remove the actuator bolts (24) and nuts from the upper and lower actuator cases. Important - leave two opposing bolts assembled.

4. Use caution when removing the final two bolts. The upper case is spring-loaded by the internal return spring (21).
5. Remove the return springs from the diaphragm plate (21).
6. Remove the valve stem bolt (31) and seal washer (27) from the diaphragm assembly.
7. Remove the seal washer (33) from the center of the diaphragm plate.
8. Lift off the diaphragm plate (20) and remove the diaphragm (19).
9. Inspect and replace as required by reversing the above steps.
10. When re-assembling, it is necessary to balance the lower support plate (11) on top of the valve plug/ stem assembly (8). Make sure the valve stem bolt engages all parts in the diaphragm assembly before tightening. Use a new seal washer (17).
11. To tighten the valve stem bolt, hold the outside of the diaphragm plate to prevent the assembly from turning while tightening the bolt.
12. Make sure to locate the return springs on the stamped guides in the diaphragm plate before assembling the upper case.
16. Assemble the plug o-ring (30) and seal (27) to the plug groove. Place an additional amount of grease on the outside of the seal and carefully insert the plug / stem into the cage (9) being careful not to damage the o-ring.
17. Place the cage and plug / stem on top of the seat assembly in the body.
18. Place a new spacer (12) on top of the cage.
19. Insert the bonnet (2) over the stem and onto the body.
20. Assemble the 4 body bolts (3) using an even cross-torquing method. Torque to 75 ft-lbs.
21. Place the packing spring (16), retainer (15), new set of packing (14), and the packing follower (15) into the packing bore of the bonnet. Lubricate each piece of packing upon installation.
22. Place the lower actuator assembly over the bonnet. Make certain the port on the lower case is oriented to the same side as when it was removed, and is 90° to the flow direction.
23. Secure the actuator nut (7) to the lower case using a minimum of 100 ft-lbs or torque.
24. Follow the steps outlined above under "Main Valve Diaphragm" to finish assembling the actuator.

Main Valve Seats

1. Remove diaphragm as listed above.
2. Remove the actuator nut (7) from the lower case.
3. Lift the lower case assembly off of the bonnet.
4. Remove the 4 body bolts (3).
5. Lift off the bonnet assembly (2) from the main valve plug / stem assembly (8).
6. Remove the plug / stem and cage (9) from the body bore. Note - the cage will normally come out with the plug.
7. Remove the seat assembly and o-ring (25) from the bore of the body.
8. Separate the plug / stem from the cage.
9. Remove plug -O-ring (30) and seal (27).
10. Clean all parts with a light solvent.
11. Replace o-ring numbers (25), (29), (30), & seal (27).
12. Use a light grease, such as Dow Corning #4 to lubricate all o-rings prior to re-assembly.
13. Place the seat o-ring (30) into the body bore, pushing it all the way into the corners of the bore.
14. Place the seat ring (13) on top of the o-ring.
15. Insert a new soft seat (10) into the groove on the seat ring.

Parts List

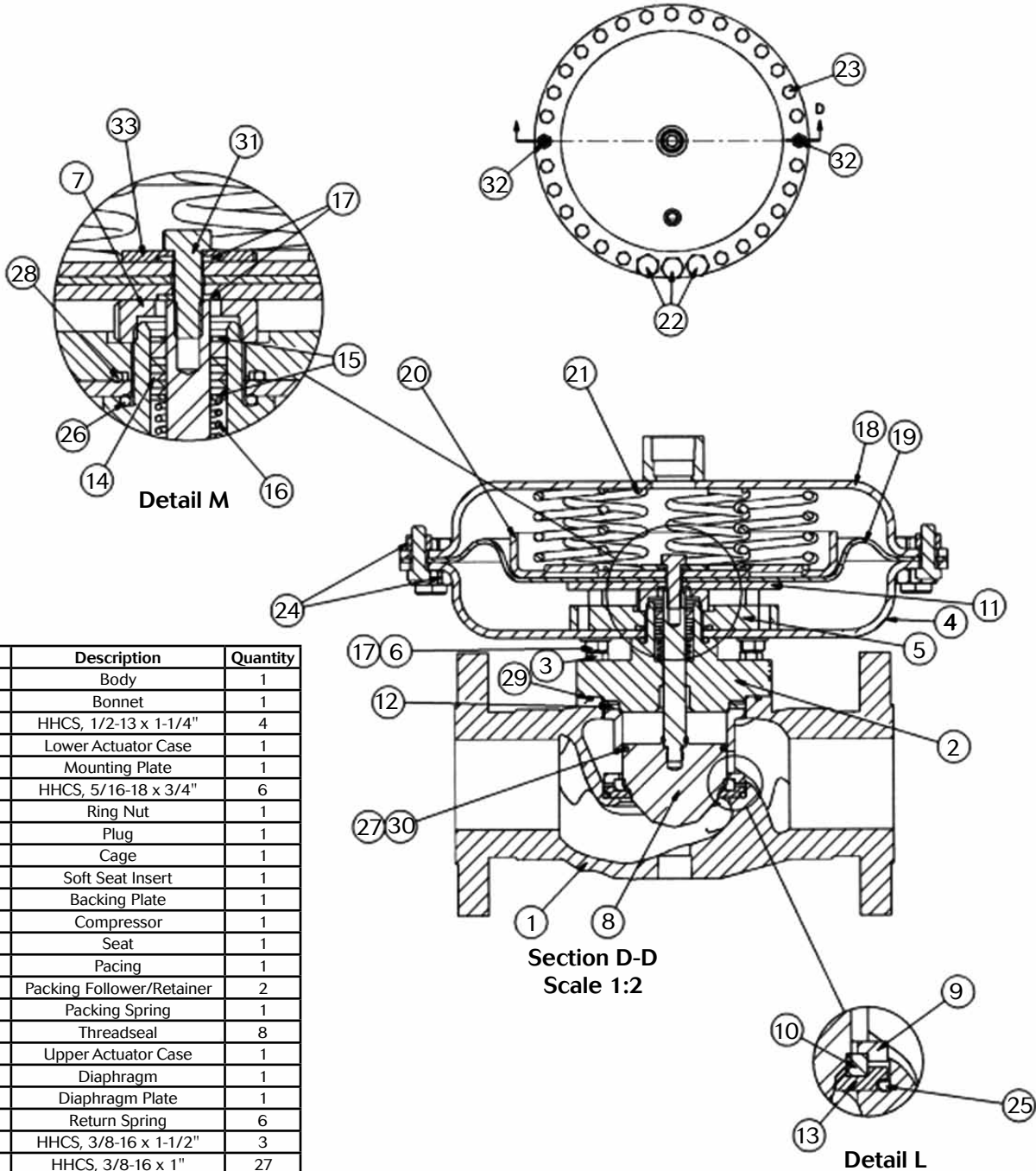

Item No.	Description	Quantity
1	Body	1
2	Bonnet	1
3	HHCS, 1/2-13 x 1-1/4"	4
4	Lower Actuator Case	1
5	Mounting Plate	1
6	HHCS, 5/16-18 x 3/4"	6
7	Ring Nut	1
8	Plug	1
9	Cage	1
10	Soft Seat Insert	1
11	Backing Plate	1
12	Compressor	1
13	Seat	1
14	Pacing	1
15	Packing Follower/Retainer	2
16	Packing Spring	1
17	Threadseal	8
18	Upper Actuator Case	1
19	Diaphragm	1
20	Diaphragm Plate	1
21	Return Spring	6
22	HHCS, 3/8-16 x 1-1/2"	3
23	HHCS, 3/8-16 x 1"	27
24	Hex Nut, 3/8-16	32
25	O-Ring #345	1
26	O-Ring #219	1
27	Plug Seal	1
28	O-Ring #222	1
29	O-Ring #154	1
30	O-Ring #138	1
31	HHCS, 5/16-18 x 1"	1
32	HHCS, 3/8-16 x 1-3/4"	2
33	Seal Washer	1
45		3



3170 Wasson Road • Cincinnati, OH 45209 USA
Phone 513-533-5600 • Fax 513-871-0105
info@richardsind.com • www.jordanvalve.com

I & M Mark 608P

Installation & Maintenance Instructions for Mark 608P Low Pressure Pilot Regulators

Warning: Jordan Valve Pressure Regulators must only be used, installed and repaired in accordance with these Installation & Maintenance Instructions. Observe all applicable public and company codes and regulations. In the event of leakage or other malfunction, call a qualified service person; continued operation may cause system failure or a general hazard. Before servicing any valve, disconnect, shut off, or bypass all pressurized fluid. Before disassembling a valve, be sure to release all spring tension.

Please read these instructions carefully!

Your Jordan Valve product will provide you with long, trouble-free service if it is correctly installed and maintained. Spending a few minutes now reading these instructions can save hours of trouble and downtime later. When making repairs, use only genuine Jordan Valve parts, available for immediate shipment from the factory.

A. DIAPHRAGM OR GASKET REPLACEMENT

1. Remove all pressure from the line as outlined under WARNING.
2. Remove the compression of the adjusting spring (47) by rotating the adjusting screw (59) counter-clockwise.
3. Loosen the spring housing bolts (48) and remove spring housing.

IF DIAPHRAGM IS NOT BEING REPLACED, SKIP STEPS 4 THRU 8.

4. Remove diaphragm subassembly by sliding it away from the valve body to disengage the lever arm (43).
5. Hold the lower diaphragm plate (57) and remove the screw (61), separating the parts.
6. Clean the surfaces on the upper and lower diaphragm plates that the diaphragm (46) seats against. Clean and degrease the threads on the lower diaphragm plate and the screw. (Degrease with Loctite primer T.)
7. Assemble the upper and lower diaphragm plates, diaphragm weight (60) to the new diaphragm with the screw. (Apply a few drops of Loctite #290 to the screw threads to lock the parts together.) The hole through the lower diaphragm plate must align with any pair of opposite holes in the diaphragm so that it will properly engage the lever when reassembled into the valve.
8. Clean the flange surface on the diaphragm housing and reinstall the diaphragm subassembly onto the lever arm.

9. Clean the flange surface on the spring housing and install a new gasket. The gasket may be temporarily held in place using a few dabs of grease.
10. Set the spring housing on top of the diaphragm housing. Using a 6" long screwdriver, or similar tool, reach through the spring housing and push the diaphragm down to align the diaphragm holes with the housings' holes.
11. Drop the bolts into place and attach the lockwashers and nuts, finger-right.
12. Continue to push the diaphragm down and snug-up the bolts.
13. Evenly torque the bolts as described in the Torque Procedure Section.
14. Install the spring and adjusting screw. (Adjusting spring per start-up instructions and replace cap.)

B. SEAT INSERT & PLUG REPLACEMENT

CAUTION: When replacing a plug or seat insert, the lever must also be replaced to insure shutoff.

1. Remove all pressure from the line as outlined under WARNING.
2. Loosen the union nut (40) and separate the actuator from the body.
3. Inspect the plug (41) and seat insert (39) to determine if replacement is required. Replace if there are signs of wear or uneven seating on either part.
4. To replace the seat, simply unscrew it from the body using a 7/8" thinwall socket wrench. Install the new seat. An anti-seize compound applied to the threads will aid in future removal.
5. To replace the plug, disassemble the actuator as described in steps A2, A3, A4.
6. Remove the two screws (49) fastening the lever arm bracket (42) to the diaphragm housing and lift out the lever arm bracket with the lever.
7. Inspect aspirating hole in aspirator to be sure it is clean. Remove and replace aspirator if stem guide bores are worn. Remove and replace plug.
8. Remove the screws from the lever arm bracket and clean the threads. Degrease with Loctite Primer T. Also clean and degrease the tapped holes in the diaphragm housing.

9. Remove the pin (45), replace the lever and reassemble with the screws.
10. Apply a drop of Loctite #290 to each screw and reinstall the lever arm bracket. Align the slot in the plug's stem with the new lever arm and tighten the pivot bracket's mounting screws. Check for free movement. Be certain that there is a gasket (36) between the guide flange and the diaphragm housing, and a gasket (37) in the body cavity where the aspirator fits.
11. Re-attach body and actuator with the union nut (being careful to align the aspirator tube to the slot in the body). Pull up hand-tight, then tighten further 1/4 turn. (The union nut is 8-sided and may be used as a guide).
12. If lever arm was replaced, apply 25-150 psi pressure through outlet. This will set linkage and prevent overpressure (in operation) from bending the linkage and causing set point changes. Seat leakage may be checked by observing any leakage from inlet.

Torque Procedure

1. Install all bolts hand-tight.
2. Torque the bolts in order of the bolt pattern to approximately 75 in.-lbs.
3. Re-torque each bolt to 300 in.-lbs., using the same bolt pattern as shown.

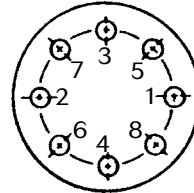

8 bolts
(or multiples)

Ordering Spare Parts

Use only genuine Jordan Valve parts to keep your valve in good working order. So that we can supply the parts, which were designed for your valve, we must know exactly which product you are using. The only guarantee to getting the correct replacement parts is to provide your Jordan Representative with the valve serial number. This number is located on the valve identification tag. If the serial number is not available, the parts needed for your valve might be determined using the following information: Model Number, Valve Body Size, Seat Material and Cv Rating, Spring Range and Set Point, Trim Material, Part Name - Number and Quantity.

NOTE: Any parts ordered without a valve serial number that are found to be incorrect are subject to up to a minimum 25% restock charge when returned.

Parts List

Item	Description	Qty.
34	Body	1
35	Lower Diaphragm Case with Gauge Tap	1
36	Upper Basket	1
37	Lower Basket	1
38	Retaining Ring, Split	2
39	Seat Insert	1
40	Union	1
41	Plug	1
42	Bracket	1
43	Lever Arm	1
44	RHMS 10-32 x 3/4"	2
45	Dowel Pin	1
46	Diaphragm	1
47	Spring	1
48	HHCS 5/16-18 x 1-1/4"	6
49	Spring Housing	1
50	Cap	1
51	Screen	1
52	Pipe Plug	1
53	Lock Washer, 5/16	6
54	Hex Nut, 5/16-18	6
55	O-Ring, #016	1
56	Guide	1
57	Lower Diaphragm Plate	1
58	Upper Diaphragm Plate	1
59	Adj. Screw Assy	1
60	Diaphragm Plate	1
61	HHCS, 1/4-20 x 1/2"	1

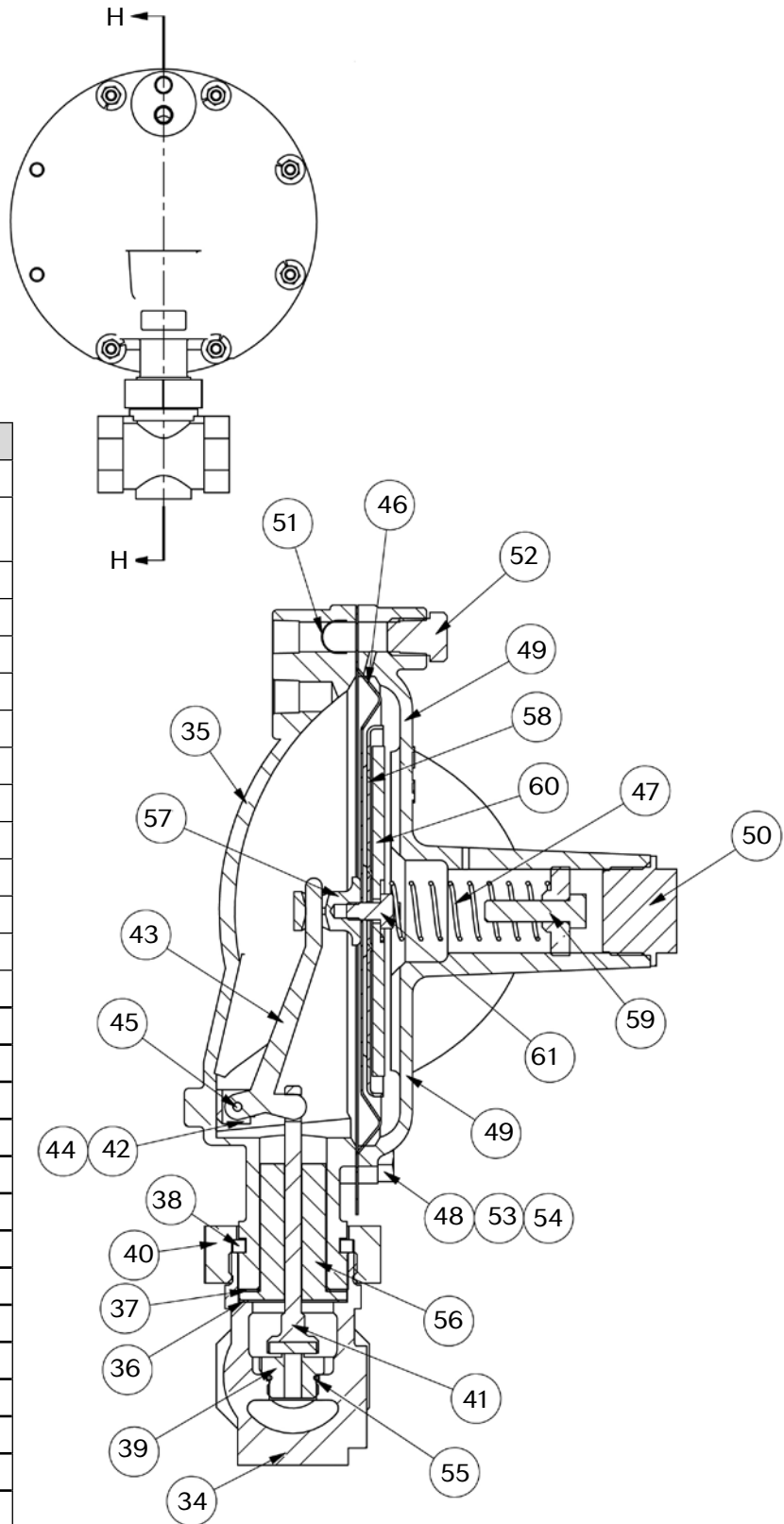



JORDAN VALVE

3170 Wasson Road • Cincinnati, OH 45209 USA
Phone 513-533-5600 • Fax 513-871-0105
info@richardsind.com • www.jordanvalve.com

I & M Mark 68G Series

Installation & Maintenance Instructions for Mark 68G Pressure Regulators (1/4" – 2")

Warning: Jordan Valve pressure regulators must only be used, installed and repaired in accordance with these Installation & Maintenance Instructions. Observe all applicable public and company codes and regulations. In the event of leakage or other malfunction, call a qualified service person; continued operation may cause system failure or a general hazard. Before servicing any valve, disconnect, shut off, or bypass all pressurized fluid. Before disassembling a valve, be sure to release all spring tension.

Please read these instructions carefully!

Your Jordan Valve product will provide you with long, trouble-free service if it is correctly installed and maintained. Spending a few minutes now reading these instructions can save hours of trouble and downtime later. When making repairs, use only genuine Jordan Valve parts, available for immediate shipment from the factory.

Ideal Installation

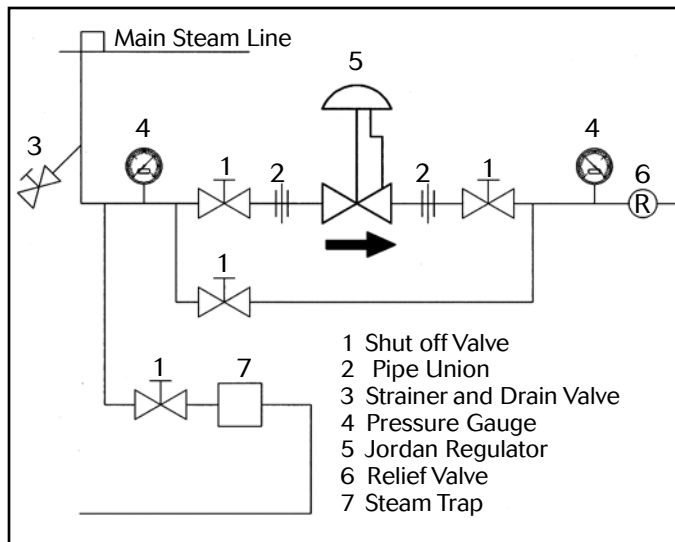

Preferred Installation

- To protect the valve from grit, scale, thread chips, and other foreign matter, all pipe lines and piping components should be blown out and thoroughly cleaned before the valve is installed.
- Shutoff valves, pressure gauges, and bypass piping should be installed as indicated in the Ideal Installation Schematic to provide easier adjustment, operation, and testing.
- In preparing threaded pipe connections, care should be exercised to prevent pipe sealing compound from getting into the pipe lines. Pipe sealing compound should be used sparingly, leaving the

- two end threads clean. Jordan uses, and recommends, thread sealer Teflon ribbon.
- A line strainer should be installed on the inlet side of the regulator to protect it from grit, scale and other foreign matter. A 0.033 perforated screen is usually suitable. Line strainers are available from Jordan Valve.
- Install the regulator in the highest horizontal line of piping to provide drainage for inlet and outlet piping, to prevent water hammer and to obtain faster regulation.
- The flow arrow on the regulator body must be pointed in the direction of flow. The regulator may be installed vertically or horizontally without affecting its operation.
- For best control, 3'0" straight sections of pipe should be installed on either side of the valve.
- In hot vapor lines, upstream and downstream piping near the regulator should be insulated to minimize condensation.
- If possible, install a relief valve downstream from the valve. Set at 15 psi above the control point of the regulator.
- Expand the outlet piping at least one pipe size if the controlled pressure (downstream) is 25% of the inlet pressure or less. A standard tapered expander connected to the outlet of the regulator is recommended.
- Where surges are severe, a piping accumulator is recommended.
- Operate the regulator within its rated pressure and temperature.

Start-Up

- Fully open the outlet shut-off valve.
- Slowly open the inlet shut-off valve.
- Slowly open and close outlet shut-off valve several times. This fully strokes the valve to insure satisfactory operation.
- With outlet shut-off valve open, slowly screw down adjusting screw until the desired pressure is shown on the outlet pressure gauge.
- To change the controlled pressure, turn the adjusting screw clockwise to increase and counter-clockwise to decrease the pressure.

Warning

Never substitute a longer length adjusting screw. Personal injury and damage to the valve may result.

Maintenance

WARNING

Be sure that there is no pressure in the valve before loosening any fittings or joints. The following steps are recommended:

1. Close the inlet shut-off valve.
2. Allow pressure to bleed off through the downstream piping. Do not attempt to reverse the flow through the valve by bleeding pressure from the upstream side of the valve.
3. When downstream pressure gauge indicates no pressure in the line, close the outlet shut-off valve.

Refer to the drawing for the proper orientation of the parts and for proper nomenclature.

Troubleshooting

Erratic Control

- Oversizing causes cycling and hunting, and reduces the rangeability of the regulator. Make certain that your sizing is correct.
- Steam traps downstream may need attention.
- Safety valve may be jammed open, disrupting the system. Repair as necessary.
- Excessive foreign matter on seat of plug (3)*. Clean them. Inspect seating surface on plug for deterioration.
- Valve stroke may not be moving freely. Check stem (22), bushing (10) or cap bore (2).

Downstream pressure build-up

- Seats deteriorated. Inspect for foreign material between plug (3) and seat (9).
- Diaphragm (11) failed. Use metal seats for tighter shut-off. Consider elastomer seats.

Cannot Maintain Regulated Pressure

- Clogged strainer or lines.
- Inlet pressure low.
- Spring (14) set too low or broken.
- Valve is undersized for rated flow.
- System demand exceeds pump capacity.

* See back page for parts call-out.

Diaphragm Replacement

1. Remove all pressure from the line as outlined under WARNING.
2. Remove the compression on the adjusting spring (14) by rotating the adjusting screw (19) counter-clockwise.
3. Remove the spring housing (17). Remove the spring (14) and spring seat (15).
4. Lift the diaphragm assembly. This diaphragm assembly consists of the upper diaphragm plate (13), diaphragm (11) and lower diaphragm plate (12).
5. Secure the upper diaphragm plate in a vise. Use a spanner wrench on the lower diaphragm plate and turn counter-clockwise to loosen and remove.
6. Remove the diaphragm, clean the parts and install the new diaphragm in reverse order. Pull the parts up tight when a metal diaphragm is used. When elastomer diaphragms are used, clean and degrease the threads, apply one drop of #290 Loctite to the threads, and assemble. (Loctite Primer T may be used to degrease). Thread the parts together, hand tight, and then tighten 1/8 to 1/4 turn.
7. Clean the diaphragm seating surfaces on the spring housing (17) and on the body (1).
8. Unscrew the cap (2) approximately two turns to retract the stem. Place the diaphragm assembly, spring, spring seat and ball bearing back onto the valve body. (Metal diaphragms nest into the counter-bore in the body).
9. Install spring housing. Tighten bolts (18) evenly per chart.
10. Thread cap back into the body and pull snug.

Seat and Plug Replacement

1. Remove all pressure from the line as outlined in the WARNING.
2. Turn the hex end on the cap (2) counter-clockwise and remove it from the body. The plug (3) and return spring (5) will come out with the cap.
3. Remove the seat (9) with a deep drive socket.
4. Inspect parts for wear and replace as required.
5. Clean all parts in the body and on the cap. Lightly lubricate these surfaces.
6. Reassemble plug spring into cap and check for smooth operation.
7. Install seat with a light coat of Teflon paste on the flat seal area and anti-seize to the threads.
8. Install bottom cap onto the body with a light coat of Teflon paste on the flat seal area and anti-seize on the threads until it bottoms out on the body and tighten.

Torque Procedure

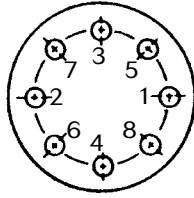
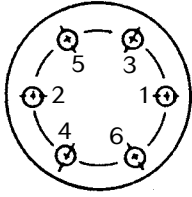

1. Install all bolts hand-tight.
2. Torque the bolts in order of the bolt pattern to a value equal to 1/4 of the recommended torque value.
3. Retorque each bolt to the recommended value using the same bolt pattern as shown.

Torque Chart for Spring Housing Bolts

Elastomer Diaphragm		Metal Diaphragm	
Bolt Size	Torque	Bolt Size	Torque
5/16	200 in-lbs	5/16	300 in-lbs
3/8	300 in-lbs	3/8	300 in-lbs

Torque Procedure

Ordering Spare Parts

Use only genuine Jordan Valve parts to keep your valve in good working order. So that we can supply the parts, which were designed for your valve, we must know exactly which product you are using. Please note the following information on the valve's nameplate:

- Serial Number
- Model and Size
- Body Material and End Connections
- Range
- Diaphragm and Seal Materials

Cross Section View

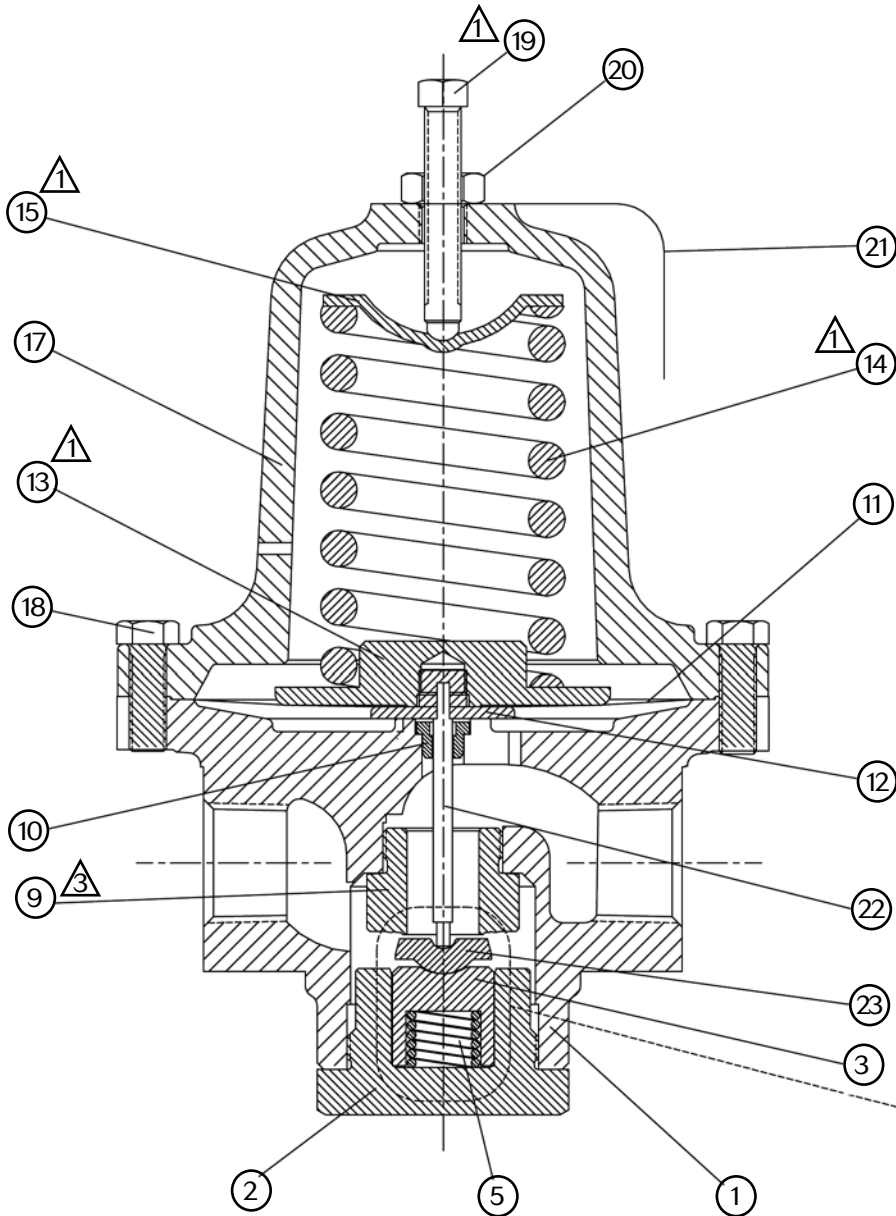

Item	Description	Qty
1	Body	1
2	Bottom Cap	1
3	Plug Assembly	1
5	Return Spring	1
9	Orifice (Seat - Std Cv)	1
10	Bushing	1
11	Diaphragm	1
12	Lower Diaphragm Plate	1
13	Upper Diaphragm Plate	1
14	Range Spring	1
15	Spring Seat	1
17	Spring Housing	1
18	HHCS	10
19	Adjusting Screw	1
20	Jam Nut	1
21	Nameplate	1
22	Stem	1
23	Hart Seat	1

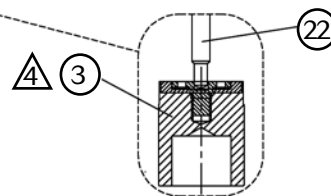

Optional
Soft Seat Trim/Plug Assembly
Seat Detail

Notes:

- These items may vary according to range feature
- 20 HHCS for MK68MP
- Orifice (seat) is stellited on MK68MP only
- Soft seat plug assembly - MK68G only