

INSTALLATION & MAINTENANCE INSTRUCTIONS

2-WAY PLASTIC BODY SOLENOID VALVES NORMALLY CLOSED OPERATION

ASCO[®]
BULLETIN
8260

Form No. V5676R2

DESCRIPTION

Bulletin 8260 valves are 2-way normally closed solenoid valves having a molded plastic body designed for both food handling and non-food handling service. Standard valves have a TYPE 1 General Purpose Solenoid Enclosure.

OPERATION

Normally Closed: Valve is closed when solenoid is de-energized. Valve opens when solenoid is energized.

METERING DEVICE (Optional)

Valves with Suffix "M" in catalog numbers are provided with a built-in metering device.

METERING DEVICE ADJUSTMENT

Increase Flow: Turn metering stem in counterclockwise direction.

Decrease Flow: Turn metering stem in clockwise direction.

INSTALLATION

Check nameplate for correct catalog number, pressure, voltage and service.

TEMPERATURE LIMITATIONS

Maximum valve ambient temperature is 77°F. Maximum valve fluid temperature is 130°F for continuous exposure and 180°F for intermittent exposure.

POSITIONING

This valve is designed to perform properly when mounted in any position. However, for optimum life and performance, the solenoid should be mounted vertically and upright to reduce the possibility of foreign matter accumulating in the plugnut/core tube sub-assembly area.

MOUNTING

For valve body mounting dimensions, refer to Figure 1.

TUBING OR HOSE CONNECTION

Connect tubing or hose to valve according to markings on valve body. Avoid tubing strain on valve body by properly supporting and aligning tubing. When tightening fittings, do not use valve body or solenoid as a lever. For valves with bib type connections, 1/4-inch O.D. hose or 1/4-inch SAE male flare ends, maximum torque for tubing connection is 25 inch-pounds (2,8 newton-meters). Valves that require compression fittings for 1/4-inch O.D. plastic or metal tubing may be provided with ferrule nuts, an optional feature. There are two different types of ferrule nuts, one for plastic tubing and one for metal tubing. Refer to diagram.

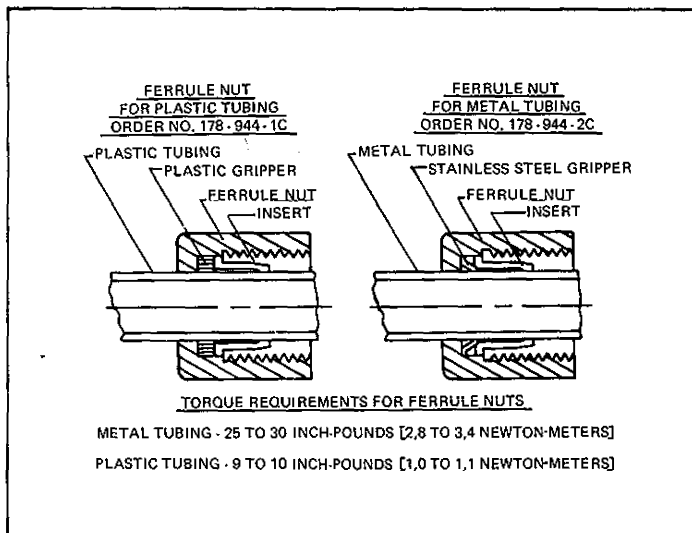

IMPORTANT: To protect the solenoid valve, install a strainer or filter, suitable for the service involved, in the inlet side as close to the valve as possible. Clean periodically depending on service conditions. See Bulletins 8600, 8601 and 8602 for strainers.

WIRING

Wiring must comply with local codes and the National Electrical Code. The solenoid housing has a 7/8-inch diameter hole to accommodate 1/2-inch conduit. On some constructions, a green ground wire is provided. To facilitate wiring, the solenoid enclosure may be rotated 360° by removing the retaining cap before operating.

SOLENOID TEMPERATURE

Coils for Bulletin 8260 valves are designed for continuous duty service. When the solenoid is energized for a long period, the solenoid enclosure becomes hot and can be touched by hand only for an instant. This is a safe operating temperature. Any excessive heating will be indicated by the smoke and odor of burning coil insulation.

MAINTENANCE

NOTE: It is not necessary to remove the valve from the pipeline for repairs.

WARNING: Turn off electrical power supply and depressurize valve before making repairs.

CLEANING

All solenoid valves should be cleaned periodically. The time between cleanings will vary depending on the medium and service conditions. In general, if the voltage to the coil is correct, sluggish valve operation, excessive noise or leakage will indicate that cleaning is required. Clean valve strainer or filter when cleaning the valve.

IN-PLACE CLEANING INSTRUCTIONS FOR DISPENSING/VENDING USAGE

1. Wash valve for two (2) minutes with a detergent solution of one (1) ounce of OAKITE[®] LIQUI-DET[®] 2 (or equivalent) to two (2) gallons of water at 120 to 140°F.
2. Rinse valve for two (2) minutes with cold water.
3. Sanitize valve for two (2) minutes with a 50 part-per-million solution of chlorine sanitizing agent.

PREVENTIVE MAINTENANCE

1. Keep the medium flowing through the valve as free from dirt and foreign material as possible.
2. While the valve is in service, operate it at least once a month to insure proper opening and closing.
3. Periodic inspection (depending on medium and service conditions) of internal valve parts for damage or excessive wear is recommended. Thoroughly clean all parts. Replace any parts that are worn or damaged.

CAUSES OF IMPROPER OPERATION

1. **Faulty Control Circuit:** Check the electrical system by energizing the solenoid. A metallic "click" signifies that the solenoid is operating. Absence of the "click" indicates loss of power supply. Check for loose or blown fuses, open-circuited or grounded coil, broken lead wires or splice connections.
2. **Burned-Out Coil:** Check for open-circuited coil. Replace coil if necessary. Check supply voltage; it must be the same as specified on nameplate.
3. **Low Voltage:** Check voltage across the coil leads. Voltage must be at least 85% of nameplate rating.
4. **Incorrect Pressure:** Check valve pressure. Pressure to valve must be within range specified on nameplate.
5. **Excessive Leakage:** Disassemble valve (see MAINTENANCE) and clean all parts. Replace worn or damaged parts. However, for best results, replace all parts as supplied with an ASCO Rebuild Kit.

COIL REPLACEMENT (Refer to Figure 2.)

WARNING: Turn off electrical power supply. Then proceed as follows:

1. Disconnect coil lead wires and green ground wire (if present).
2. Remove retaining cap, nameplate and cover.
3. Pull yoke containing coil, sleeves, ground wire terminal (if present) and insulating washers off the plugnut/core tube sub-assembly. Insulating washers are omitted when a molded coil is used.
4. Pull coil, sleeves, ground wire terminal (if present) and insulating washers from yoke.
5. Reassemble in reverse order of disassembly. Use exploded view provided for identification and placement of parts.

CAUTION: Solenoid must be fully reassembled because the housing and internal parts complete the magnetic circuit. Place insulating washers (except for molded coils) on each end of coil.

VALVE DISASSEMBLY AND REASSEMBLY

(Refer to Figure 2.)

Depressurize valve and turn off electrical power supply.

1. Remove retaining cap and pull entire solenoid enclosure off plugnut/core tube sub-assembly. Remove bracket screws (2) and lower bracket.
2. Remove plugnut/core tube sub-assembly with upper bracket and core tube gasket attached.
3. Remove core spring, core assembly and body gasket.
4. For metering device, remove self-tapping screw, retainer and metering stem with stem gasket attached.
5. All parts are now accessible for cleaning or replacement. Replace worn or damaged parts. However, for best results, replace all parts as supplied with a complete ASCO Rebuild Kit.
6. Reassemble in reverse order of disassembly. Use exploded view provided for identification and placement of parts.
7. **IMPORTANT:** Tighten the bracket screws (2) evenly to insure proper gasket compression. Torque screws to 30 ± 5 inch-pounds ($3,4 \pm 0,5$ newton-meters).
8. After maintenance is completed, operate valve a few times to be sure of proper operation.

ASCO REBUILD KITS

Rebuild Kits and Coils are available for ASCO valves.
Parts marked with an asterisk (*) are supplied in Rebuild Kits.

ORDERING INFORMATION FOR REBUILD KITS

When Ordering Rebuild Kits or Coils,
Specify Valve Catalog Number,
Serial Number, Voltage
and Frequency.

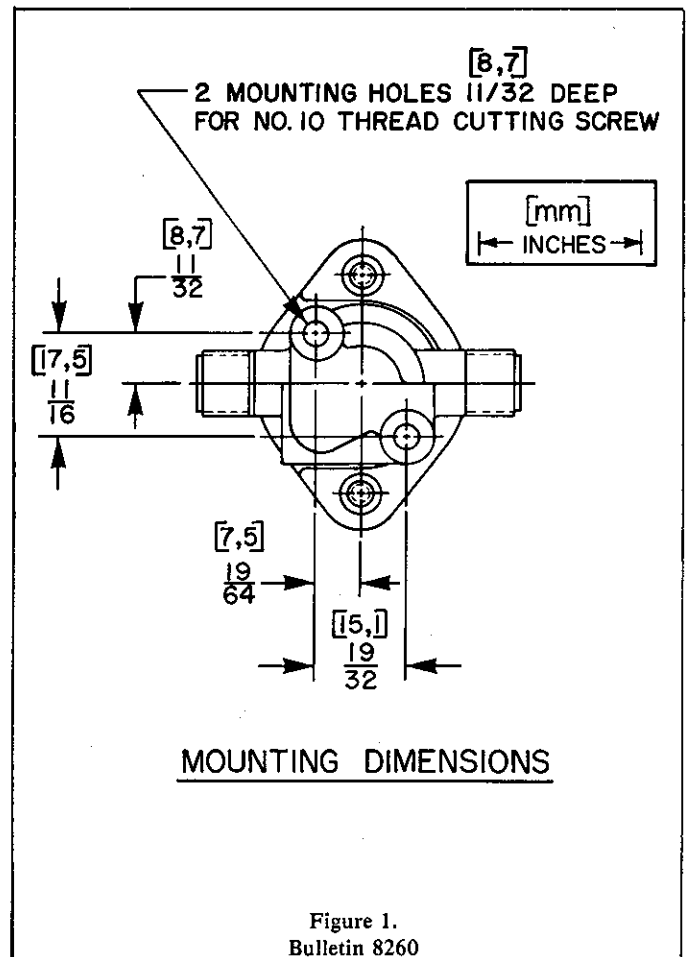

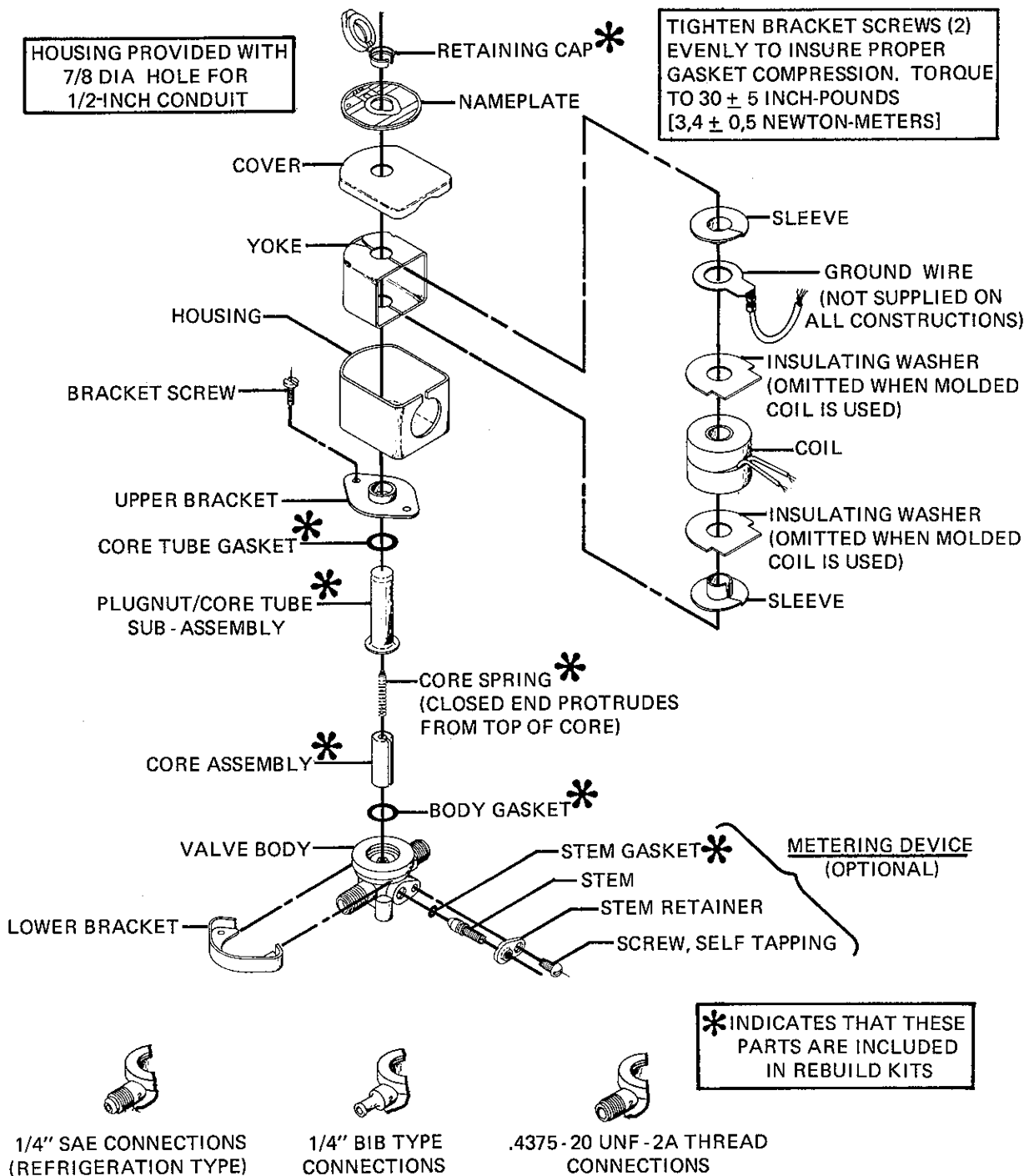

Figure 2.
Bulletin 8260



ASCO Valves

Automatic Switch Co. 50-56 Hanover Road, Florham Park, New Jersey 07932

Form No. V5676R2

Printed in U.S.A.

© Automatic Switch Co. MCMXXXIII. All Rights Reserved