

Quick Start Manual • October 2003



English
Dansk
Deutsch
Ελληνικά
Español
Français
Italiano
Nederlands
Português
Suomi
Svenska

multiranger

100 / 200

SIEMENS

MultiRanger Quick Start Manual

The MultiRanger is a versatile and dependable level-monitoring instrument using advanced ultrasonic techniques.

The MultiRanger is to be used only in the manner outlined in this manual, otherwise protection provided by the equipment may be impaired.

This manual outlines the essential features and functions that apply to the MultiRanger 100 and the MultiRanger 200. Features that apply to the MultiRanger 200 are clearly marked.

We strongly advise you to acquire the detailed version of the manual so you can use your device to its fullest potential. The complete manual is available on our Web site: www.siemens-milltronics.com.

The printed manual is available from your local Siemens Milltronics representative.

Questions about the contents of this manual can be directed to:

Siemens Milltronics Process Instruments Inc.
1954 Technology Drive, P.O. Box 4225
Peterborough, Ontario, Canada, K9J 7B1
Email: techpubs@siemens-milltronics.com

**Copyright Siemens Milltronics
Process Instruments Inc. 2002.
All Rights Reserved**

Disclaimer of Liability

We encourage users to purchase authorized bound manuals, or to view electronic versions as designed and authored by Siemens Milltronics Process Instruments Inc. Siemens Milltronics Process Instruments Inc. will not be responsible for the contents of partial or whole reproductions of either bound or electronic versions.

While we have verified the contents of this manual for agreement with the instrumentation described, variations remain possible. Thus we cannot guarantee full agreement. The contents of this manual are regularly reviewed and corrections are included in subsequent editions. We welcome all suggestions for improvement.

Technical data subject to change.

MILLTRONICS® is a registered trademark of Siemens Milltronics Process Instruments Inc.

Safety Guidelines

Warning notices must be observed to ensure personal safety as well as that of others, and to protect the product and the connected equipment. These warning notices are accompanied by a clarification of the level of caution to be observed.

Warning: This product can only function properly and safely if it is correctly transported, stored, installed, set up, operated, and maintained.

Specifications

For a complete listing, see the MultiRanger Instruction manual. For Approval information, please refer to the MultiRanger nameplate.

Power

AC Version

- 100-230 V AC \pm 15%, 50 / 60 Hz, 36 VA (17W)¹
- fuse: F3: 2 AG, Slow Blow, 0.375A, 250V

DC Version

- 12-30 V DC, 20W¹
- fuse: F3: 2 AG, Slow Blow, 2A, 250V

¹Power consumption is listed at maximum.

Installation Conditions

Altitude

- 2000m max

Ambient Temperature

- -20 to 50 °C (-5 to 122 °F)

Installation Category

- II

Pollution Degree

- 4

Range

- 0.3 m (1 ft) to 15 m (50 ft), transducer dependent

Outputs

Transducer Drive

- 315 V peak

mA Analog

- 0-20 mA
- 4-20 mA
- 750 ohm maximum
- Resolution of 0.1%

Relays¹

- **Three:** 2 control, 1 alarm control
- **Six:** 4 control, 2 alarm control
- all relays rated 5 A at 250 V AC, non-inductive

Control Relays

- 2 or 4 Form **A, NO** relays (relays numbered 1, 2, 4, 5)

Alarm/Control Relays

- 1 or 2 Form **C, NO, or NC** relay (relays numbered 3, 6)

Communication

- RS-232 (Modbus RTU and ASCII via RJ-11 connector)
- RS-485 (Modbus RTU) via terminal blocks

¹All relays are certified only for use with equipment that fails in a state at or under the rated maximums of relays.

Inputs

mA (analog) (1) [MR 200 only]

- 0-20 or 4-20 mA, from alternate device, scalable

Discrete (2)

- 10-50 V dc switching level
- logical 1 = 10 to 50 V DC
- logical 0 = < 0.5 V DC
- 3 mA maximum draw

Transducers

Compatible

- Echomax series
- STH series
- (44 kHz)

Cable (365m Max)

- do not use coaxial cable for transducers
- 2-3 copper conductors, twisted with shield, drain wire, 300Vrms, 0.5mm² (22-18AWG), nominal capacitance between adjacent conductors @ 1 kHz = 19pF/ft., nominal capacitance between conductor and shield @ 1kHz = 33 pF/ft. (Belden 8760 is acceptable).

Installation

Notes:

- Installation shall only be performed by qualified personnel and in accordance with local governing regulations.
- This product is susceptible to electrostatic shock. Follow proper grounding procedures.



All field wiring must have insulation suitable for at least 250 V.



Hazardous voltage present on transducer terminals during operation.



DC terminals shall be supplied from an SELV source in accordance with IEC 1010-1 Annex H.

- The non-metallic enclosure does not provide grounding between conduit connections. Use grounding type bushings and jumpers.

Wall Mount Installation

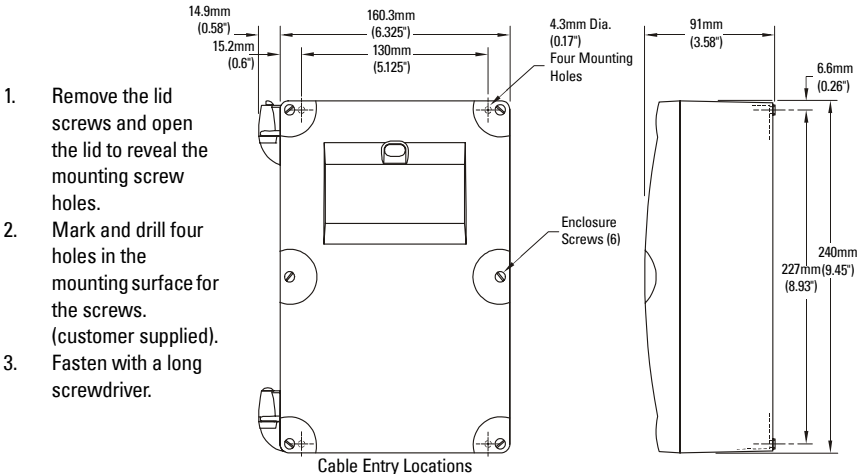

Conduit Cable Entry

1. Remove screws holding motherboard and pull straight out.
2. Drill cable entry holes carefully, leaving room for existing contents.
3. Attach conduits using approved suitably sized hubs for watertight application.

Exposed Cable Entry (supplied glands)

1. Unscrew glands and attach loosely to enclosure.
2. Thread cables through glands. Keep power cable separate from signal cable.
3. Wire cables to terminal blocks and tighten glands to form a good seal.

Note: For conduit locations and assembly for mounting in Class 1, Div. 2 applications, please see Drawing 23650314 in Appendix A.

Panel Mount Installation

Installing the panel mount unit requires making a cutout in the panel. The cutout template is provided with your unit or may be downloaded from www.siemens-milltronics.com.

Panel Mount Dimensions

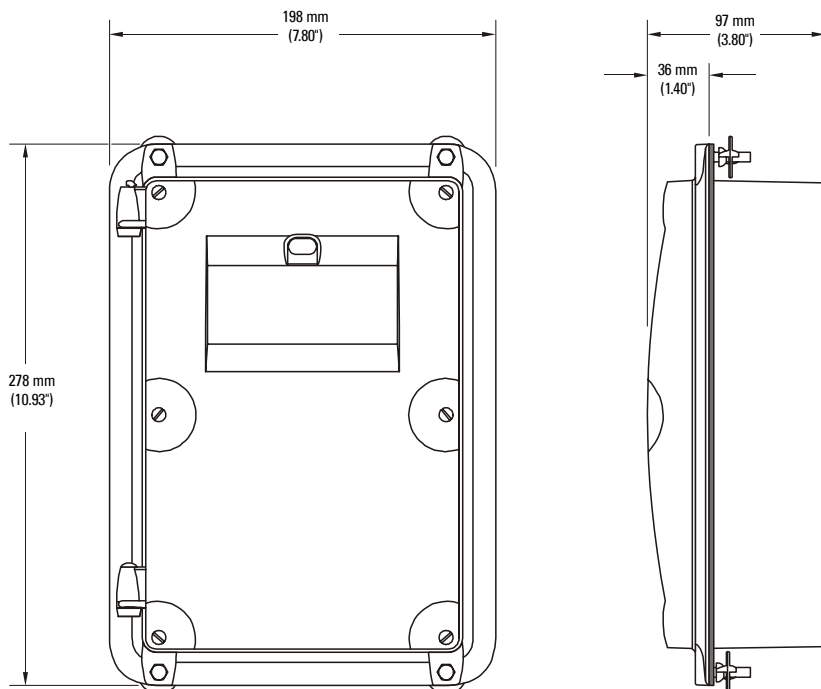

Mounting the Enclosure

Once cutout is complete and mounting holes are drilled, follow these steps:

1. Remove lid from unit by undoing the six lidscrews and lifting it off its hinges.
2. Remove the four screws holding the motherboard to the enclosure.
3. Be careful not to damage the electronics with static electricity. Remove the motherboard from the enclosure by pulling the board straight out.
4. Drill the required cable entry holes. Be sure to compensate for panel door dimensions and make sure conduit holes do not interfere with the lower areas on the terminal block, circuit board, or SmartLinX card.
5. Replace board and fasten the four screws.
6. Place the unit into the panel and insert hexagonal fasteners through bevel slots and predrilled panel holes.
7. Fasten with wingnuts and hand tighten.
8. Add conduit or glands and wire as required, then replace the lid.

Helpful hint:

- Use tape to hold hexagonal heads in slots while attaching wingnuts.

Notes:

- For complete wiring instructions, please refer to the Instruction Manual.
- Verify that all system components are installed in accordance with instructions.
- Connect all cable shields to the MultiRanger Shield Connections. Avoid Differential ground potentials by not connecting cable shields to ground (earth) anywhere.
- Keep exposed conductors on shielded cables as short as possible to reduce noise on the line caused by stray transmissions and noise pickup.

Terminal Board

The terminal board on the MultiRanger allows all inputs and outputs to be connected simultaneously.

Note:

Recommended torque on terminal clamping screws:

- 0.56 – 0.79 Nm (5 – 7 in.lbs)

Please do not overtighten the screws

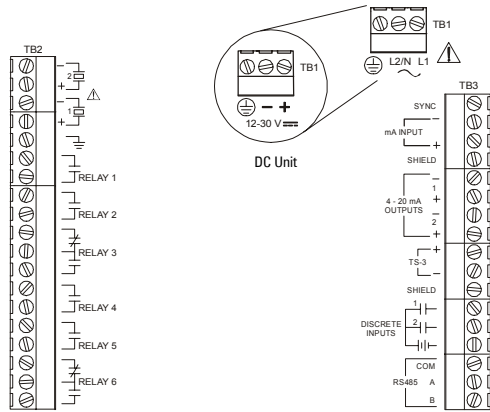

Transducers



Warning: Hazardous voltage present on transducer terminals during operation.

Run the transducer cable in a grounded metal conduit, separate from other wiring (except TS-3 temperature sensor wiring, if applicable).

Notes

- Do not use coaxial cable because of electrical noise interference
- Do not connect the shield and white transducer wires together; wire to separate terminals.
- Disregard transducer manuals recommending these practices

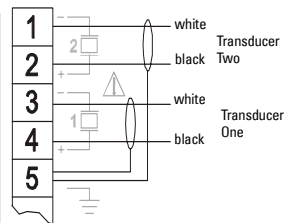

A 0.1 μ F (100V or greater) capacitor is included with the MultiRanger for retrofitting old MultiRanger Plus installations. Please refer to *General Appendix F-Upgrading* in the complete MultiRanger Instruction Manual for more information.

Relays

Relay contacts are shown in the de-energized position. All relays are handled identically and can be configured as positive or negative logic using P118 (See Instruction Manual).

Relay Ratings: all relays are rated at 5A at 250V ac, non-inductive

Three Relay Model

- 2 control
- 1 alarm/control
- Relays 1, 2, 3

Six Relay Model

- 4 control
- 2 alarm/control
- Relays 1 to 6

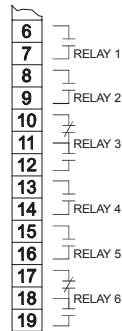

Control Relays

- Form A, NO, Relays 1, 2, 4, and 5

Alarm/Control Relays

- Form C, NO or NC, Relays 3, 6

Power Failure:

- Relays 1, 2, 4, and 5 are NO and will fail in the normal state.
- Relays 3 and 6 are wired either NO or NC, and will fail in their de-energized states.

mA Output

For more information, consult the mA output parameters (P200 to P219) in the parameter reference section of the Instruction Manual.

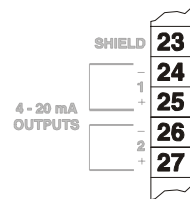

Power

Important!

- Before applying power to the MultiRanger for the first time, ensure any connected alarm/control equipment is disabled until satisfactory system operation and performance is verified.
- Please make sure unit is connected to a reliable ground.

Notes for AC power connections

- The equipment must be protected by a 15 A fuse, or circuit breaker in the building installation.
- A circuit breaker or switch in the building installation, marked as the disconnect switch, must be in close proximity to the equipment and within easy reach of the operator.

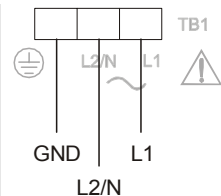



Operating the MultiRanger

The MultiRanger has two modes of operation PROGRAM and RUN. PROGRAM mode lets you configure the MultiRanger to fit your application.

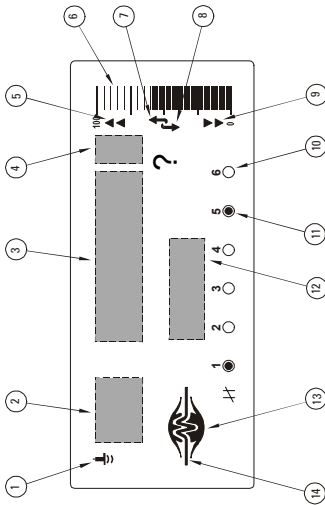
MultiRanger Display and Indicator Functions



RUN Mode	PROGRAM Mode
1 index type	index type
2 index	index
3 primary reading	parameter value
4 units	units
5 hi and hi hi alarm designation	auxiliary function
6 level display	n/a
7 filling display	scroll access tag
8 emptying display	scroll access tag
9 lo and lo lo alarm designation	n/a
10 relay # programmed flashing = unavailable	relay # programmed flashing = unavailable
11 relay # activated	relay # activated
12 auxiliary reading	parameter number
13 normal operation: 	n/a
14 failsafe operation: 	n/a



Programming

The MultiRanger is programmed by setting its parameters to match your specific application. In PROGRAM mode, these parameter values are changed to set operating conditions. The MultiRanger is programmed with the hand programmer. Point to the infrared port above the display and press keys.





Activating the MultiRanger

All the instructions assume that the MultiRanger is activated.

Note: On powering up, a single point unit displays distance; a dual point unit displays **OFF**.

1. Power the MultiRanger.
2. Point the programmer at the unit and press PROGRAM .
3. Press DISPLAY .

Changing Parameters

1. In RUN mode, press PROGRAM . Press DISPLAY  to put the unit into PROGRAM mode.
2. Press DISPLAY  to select the Parameter Number field.
3. Enter the Parameter Number. After the third digit is entered, the parameter value is shown.
4. Enter the new value, and press ENTER .

Quick Start Parameters

Notes:

- P000 locks the unit, The unlocking value is 1954. All other values lock the unit.
- Defaults are shown with an *

P001 Operation: Sets the type of measurement required for the application.

Primary Index	Standard Mode		Dual Point Mode
	Global		Transducer
Values	0		Out-of-service
	1		Material Level
	2		Space
	3	*	Distance (transducer to material)
	4		DPD – dual point difference
	5		DPA – dual point average
	6		OCM – open channel flow rate
7		Pump Totalizer	

P002: Material: Measures material type. Liquid, may involve solids.

Primary Index	Standard Mode		Dual Point Mode
	Global		Transducer
Values	1	*	Liquid or horizontal solid surface
	2		Solid or angled surface

P003 Maximum Process Speed: Determines level change reaction.

Primary Index	Transducer		
Values	1		Slow (0.1 m/min)
	2	*	Medium (1 m/min)
	3		Fast (10 m/min)

P004 Transducer: Specifies transducer.

Primary Index	Standard Mode		Dual Point Mode
	Global		Transducer
Values	0	*	No transducer attached (preset for Dual Point)
	1		ST-25
	2		ST-50
	100		STH
	101		XCT-8
	102	*	XPS-10 (preset for Standard Mode)
	103		XCT-12
	104		XPS-15
	112		XRS-5
	250		mA input

P005 Units: Specifies units used for dimensional values.

Primary Index	Global		
Values	1	*	Meters
	2		Centimeters
	3		Millimeters
	4		Feet
	5		Inches

P006 Empty: Distance in Units (P005) from transducer face to process empty point.

Primary Index	Transducer		
Values	Range: 0.000 to 9999		
	Preset: 5.000m (or equivalent depending on units)		
Alters	• P007 Span		
Altered By	• P005 Units		

P007 Span: Sets range levels to be measured.

Primary Index	Level		
Values	Range: 0.000 to 9999		
	Preset: based on Empty (P006)		

Note: Please refer to the Instruction Manual to set up inputs, alarms and controls, communications, and other functionality.

Troubleshooting

Symptom	Cause	Action
Display blank, transducer not pulsing.	No power.	Check power supply, wiring, or power fuse.
No response to programmer.	Obstructed infrared interface, defective programmer.	Check programmer usage: 15 cm (6") from faceplate pointed at upper target.
Displays Short and tb:1#	Short circuited transducer cable, or defective transducer at indicated terminal block number.	Repair or replace as necessary.
Displays Open and tb:1#	Transducer not connected or connection reversed.	Check connection to displayed terminal blocks
	Open circuited transducer cable, or defective transducer at indicated terminal block number.	Repair or replace as necessary.
Displays LOE	Weak or non-existent echo.	Relocate and/or re-aim transducer.
		Proceed to Measurement Difficulties.
Displays Error and tb:1#	Wrong transducer selected (P004).	Re-enter correct transducer type.
	Transducer connected in "two wire" method.	Do not tie white and shield together, use all three terminal blocks.
	Transducer connected backwards.	Reverse black and white wires on terminal block.
Displays EEEE	Value too large to display in 4 or 5 characters.	Select larger Units (P005), or lower Convert Reading (P061).
Reading fluctuates while material level is still (or vice versa).	Incorrect measurement stabilization.	Alter Maximum Process Speed (P003) or damping (P704).
Reading is fixed, regardless of the actual material level.	Transducer acoustic beam obstructed, standpipe too narrow, or transducer ringing (reads over 100%).	Relocate and / or re-aim transducer at material level or object.
		Go to Measurement Difficulties below.
		See also: Transducer Ringing.
Material level reported is always incorrect by the same amount.	Incorrect Empty (zero) reference for level operation (P001 = 1).	See Empty (P006), Reading Offset (P063), Offset Calibration (P650), and Offset Correction (P652).
Measurement accuracy improves as level nears transducer.	Incorrect Sound Velocity used for distance calculation.	Use transducer with built-in temperature sensor or a TS-3 temperature sensor.
		See Sound Velocity.
Reading is erratic, with little or no relation to material level.	True echo too weak or wrong echo being processed.	Relocate and / or re-aim transducer.
		Check noise parameters.

Note: Please refer to the complete Instruction Manual for further information.

