

HC900 Control Station

Model Number 900CS10-00

Installation

Document Number: 51-52-33-157 Revision 1

Effective: 4/23/09

Supersedes: none

Summary

ATTENTION	Failure to follow these installation instructions could result in diminished performance and/or invalidate the UL approvals.
-----------	--

These instructions explain how to install your Control Station. Once installed, the unit must be configured. Configuration is a detailed process described in other documents.

The overall steps for getting your Control Station up and running are as follows.

Step	Action
1	Install the unit per this instruction sheet.
	<i>Refer to other documentation for details on the following steps.</i>
2	After completing installation, configure the HC900 controller for your application using Hybrid Control Designer software and save the .cde file.
3	Using Station Designer software, create data tags from your .cde file, create your operator interface configuration and save the .sds file.
4	Download the .sds file to the 900 Control Station and verify operation.

Note: Configuration of the 900 Control Station may be performed prior to mounting if found to be more convenient when using the USB port since once loaded the configuration is maintained in non-volatile memory, but doing so requires the station to be connected to a 24Vdc power supply.

Contents of package

Check that you received the following items.

- Control Station
- Panel Gasket
- Template for panel cutout
- Hardware packet for mounting unit into panel
- Power connector (3 terminals)
- Documentation CD

Supplied separately

- Adapter Plate Kit (optional, use if replacing Honeywell 1042 Operator Interface.)
- Flash Memory Module (optional) Note: The Flash Memory Module must be a UL approved component to maintain UL station approval when installed.

Installation procedure overview

Refer to the pages shown for details on each step.

<u>Step</u>	<u>See page</u>
1. Install Flash Memory Module (if purchased separately)	2
2. Mount the Control Station	3
3. Connect to earth ground	5
4. Mount and connect power supply	5
5. Connect communications	6

1. Install Flash Memory Module (if purchased separately)

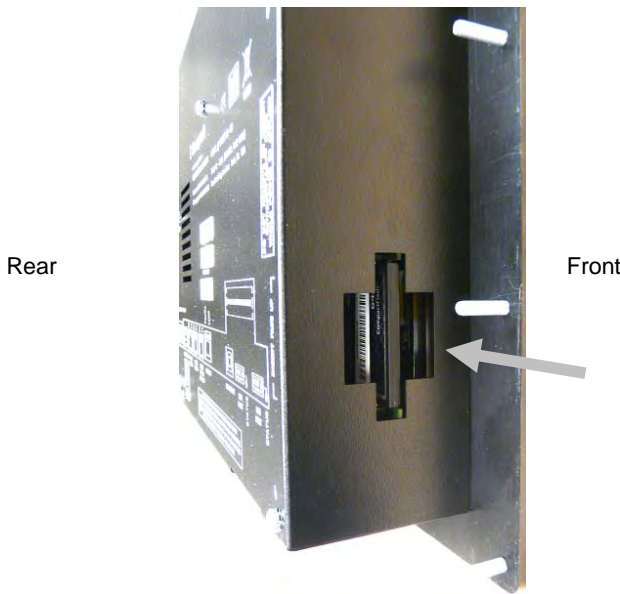
Step	Action
1	<p>With the 900 Control Station positioned face down on a clean, flat surface, and with connectors facing you, locate the Flash Memory Module receptacle through the access hole on the right side of the case.</p> 
2	<p>Insert the Flash Memory Module into the connector, face-side up, being sure the card is fully engaged in its receptacle.</p>
Note	<p>The Flash Memory Module should not be installed or removed while the Control Station has power applied.</p>

2. Mount the Control Station

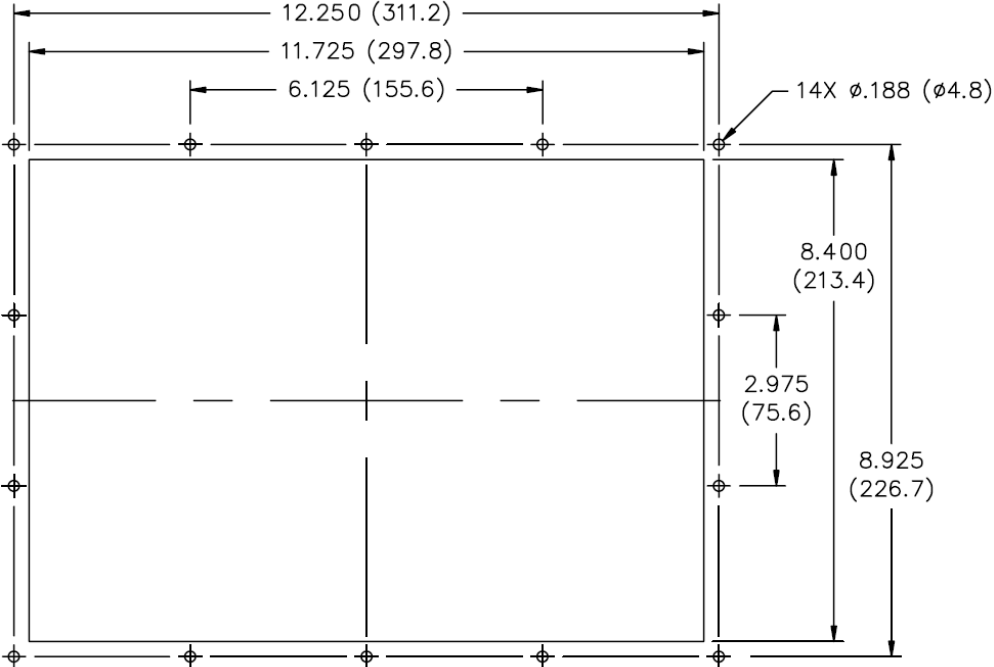
Step	Action
<p>1</p>	<p>ATTENTION: If you are replacing a 559 or 1042 Operator Interface, skip this step and go to page 11 instead.</p> <p>Using the drawing below, cut panel hole. You can use the cardboard template as a rough guide but be sure to measure against the drawing below before cutting. Drill holes using a 3/16 inch (4.76mm) size drill bit. Remove any loose material from the mounting cut-out to prevent that material from falling into the Control Station during installation.</p>  <p>The drawing shows a rectangular panel cutout with the following dimensions and features:</p> <ul style="list-style-type: none"> Overall width: 12.250 (311.2) Overall height: 8.925 (226.7) Distance from left edge to first hole: 11.725 (297.8) Distance between adjacent holes: 6.125 (155.6) Distance from right edge to last hole: 8.400 (213.4) Distance from top edge to first hole: 2.975 (75.6) Number of holes: 14 Hole diameter: $\phi.188$ ($\phi 4.8$) <p>All tolerances ± 0.010" (± 0.25 mm).</p>
<p>2</p>	<p>Mount the gasket by placing its 14 holes over the Control Station's 14 mounting bolts. Push gasket all the way on to the mounting bolts. Insert Control Station into panel cutout.</p>
<p>3</p>	<p>Install the 14 keps provided with the Control Station. Tighten evenly for uniform gasket compression. Do not tighten the keps beyond a maximum of 17 inch-pounds (1.92 N-m) or you may cause damage to the Control Station's front panel.</p>

General wiring considerations

- Use Division 2 wiring methods as specified in Article 501-4 (b), 502-4 (b), and 503-3 (b) of the National Electrical Code, NFPA 70 for installation within the United States, or as specified in section 19-152 of Canadian Electrical Code for installation in Canada.
- The Control Station cables contain low voltages. Keep cables away from high voltage wires that can cause interference.
- CE testing was performed with shielded, twisted pair cables. For noise reduction tips, see Honeywell document 51-52-05-01, How to Apply Digital Instrumentation in Severe Electrical Noise Environments.



EXPLOSION HAZARD

The Control Station has multiple cable connections. Do not connect or disconnect cables unless power has been switched off or the area is known to be non-hazardous. Failure to do so may result in death or serious injury.



ATTENTION

The emission limits of EN 55011 (CISPR11) are designed to provide reasonable protection against harmful interference when this equipment is operated in an industrial environment. Operation of this equipment in a residential area may cause harmful interference. This equipment generates, uses, and can radiate radio frequency energy and may cause interference to radio and television reception when the equipment is used closer than 30 meters to the antenna(e). In special cases, when highly susceptible apparatus is used in close proximity, the user may have to employ additional mitigating measures to further reduce the electromagnetic emissions of this equipment.

3. Connect to earth ground

The back of the unit has a chassis ground terminal identified with the symbol . Connect this terminal to earth ground (protective earth).

The chassis ground is not connected to signal common of the unit electronics. Maintaining isolation between earth ground and signal common is not required to operate the unit, but when connecting the HC900 controller to the unit using the recommended shielded CAT5 Ethernet cable, a path to earth ground is created via the Ethernet shield of the controller. Other equipment connected to the unit may require isolation between signal common and earth ground. To maintain isolation, care must be taken when connections are made to the unit. For example, a power supply with isolation between its signal common and earth ground must be used.

Connecting a device via a USB cable may also connect signal common and earth ground. The shield of the USB's connector at the host may be connected to earth ground. A USB's shield may also be connected to signal common.

4. Mount and connect power supply

The Control Station requires a 24 VDC power supply rated at 29 W or more. Your unit may draw considerably less than rated power depending upon the options being used. As additional features are used your unit will draw increasing amounts of power. Items that could cause increases in current are additional communications, Flash Memory Module, and other features programmed using Station Designer software.

It is important that the power supply is mounted and wired correctly if the unit is to operate reliably. Please take care to observe the following points.

- The power supply should be mounted close to the unit. Recommended not more than 6 feet (1.8 m) of cable between the supply and the Control Station. Ideally, the shortest length possible should be used.
- A power supply with isolation between its signal common and earth ground must be used.
- The wire used to connect the power supply to the Control Station should be at least 22-gage wire. If a longer cable run is used, a heavier gage wire should be used.
- The routing of the cable should be kept away from large contactors, inverters, and other devices which may generate significant electrical noise.
- A power supply with a Class 2 or SELV rating should be used. A Class 2 or SELV power supply provides isolation to accessible circuits from hazardous voltage levels generated by a mains power supply due to single faults. SELV is an acronym for "safety extra-low voltage." Safety extra-low voltage circuits shall exhibit voltages safe to touch both under normal operating conditions and after a single fault, such as a breakdown of a layer of basic insulation or after the failure of a single component has occurred.
- If the power supply will be mounted in a hazardous location, it must be rated for Class I, Div. 2 by an OSHA recognized NRTL, such as UL or FM.
- Using the terminal block provided, connect the power supply's +24Vdc lead to terminal 2 and the Common lead to terminal 1. See figure below. Plug the terminal block into the connector located on the bottom of the interface.

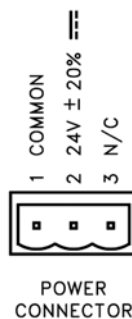

5. Connect communications

Overview

Connections and ports used depend on the architecture of your installation.

See architecture examples starting on page 6.

For cabling and connections, see page 9.

For details on connections to devices other than the Control Station, see *HC900 Hybrid Controller Installation and User Guide*, document number 51-52-25-107.

When your connections are finished, installation is complete and your unit is ready to be configured. Refer to the appropriate manuals for details.

Example #1

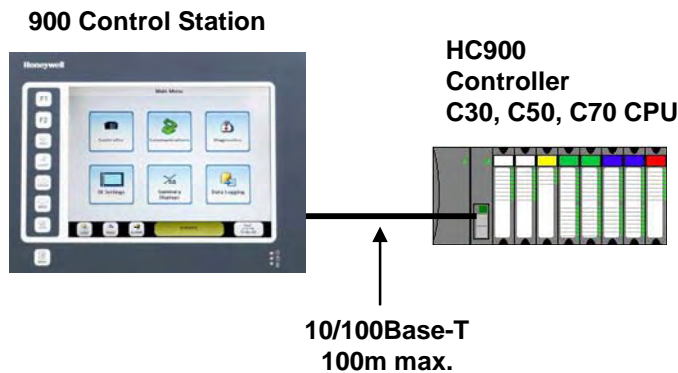

Use shielded CAT5 cable with RJ45 connectors. Connect to HC900 Ethernet port. (On models C70 and C70R with two ports E1 and E2; either port can be used.)

Example #2

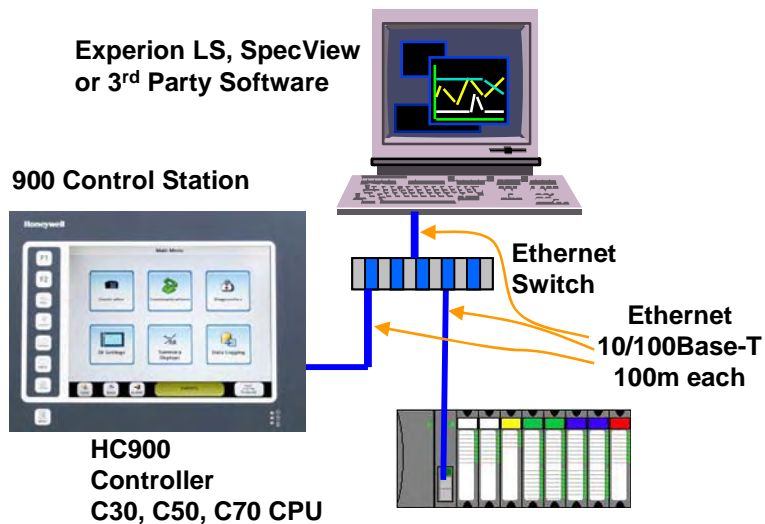

Use shielded CAT5 cable with RJ45 connectors. Connect to HC900 Ethernet port. (On models C70 and C70R with two ports E1 and E2; either port can be used.)

Example #3

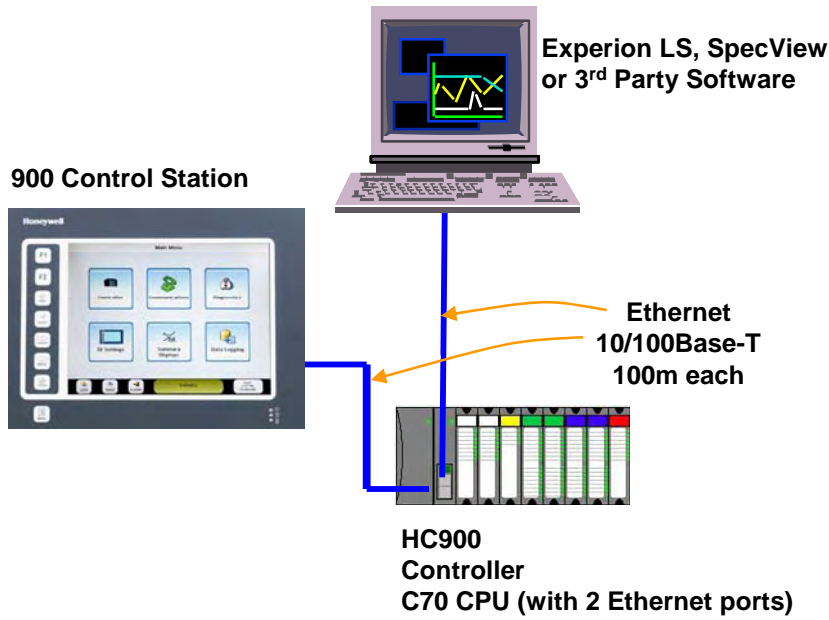

Use shielded CAT5 cable with RJ45 connectors. Connect to HC 900 to E2 of the C70 CPU and connect the host PC to E1.

Example #4

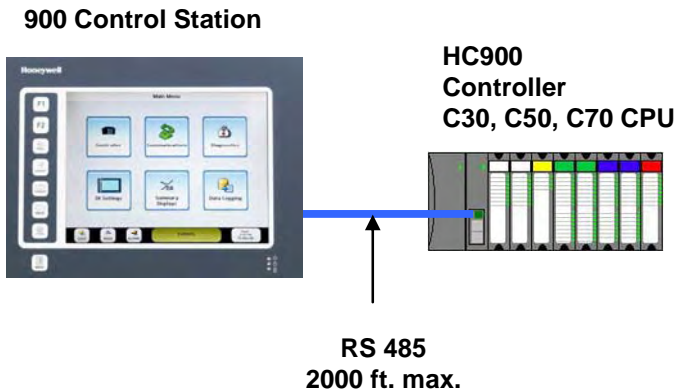

Connect to HC900 RS485 port with unterminated switch settings. S2 port is RS485 terminated by default; S1 port can be configured as RS485.

RS-232	RS-485 unterminated	RS-485 terminated (last link in network)	RS-485 with external bias, unterminated

See manual 51-52-25-107 for full details.

Note: Ethernet connections will provide faster performance than RS-485.

Example #5

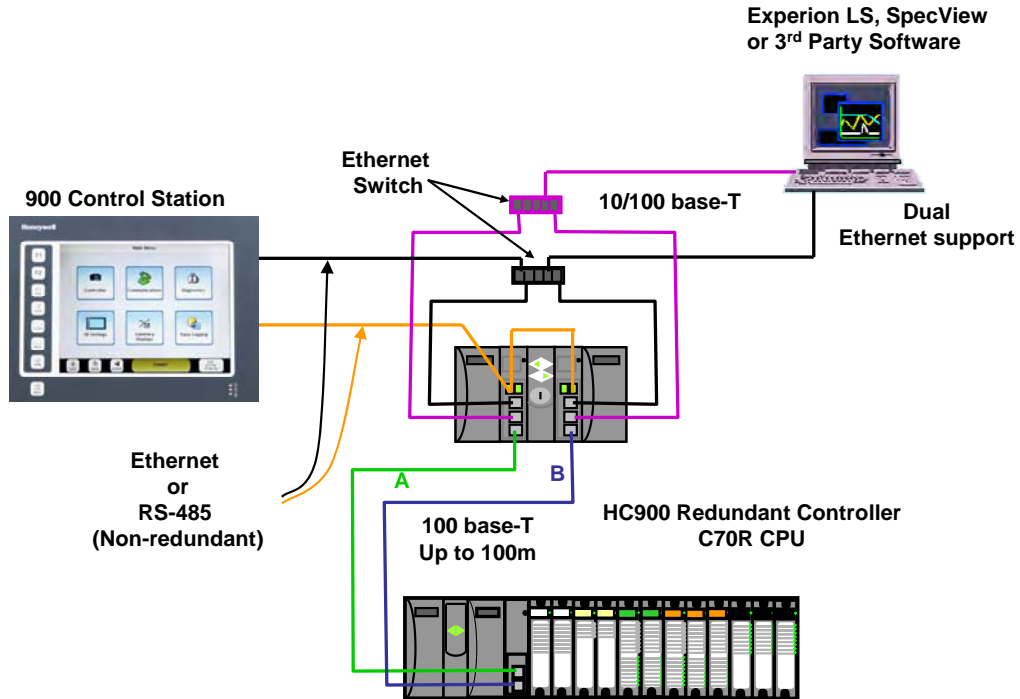

Connect to C70R using either RS-485 or Ethernet. Communication redundancy is not supported using both RS 485 and Ethernet. Communications to the Lead CPU is maintained following a CPU failover event.

Example #6

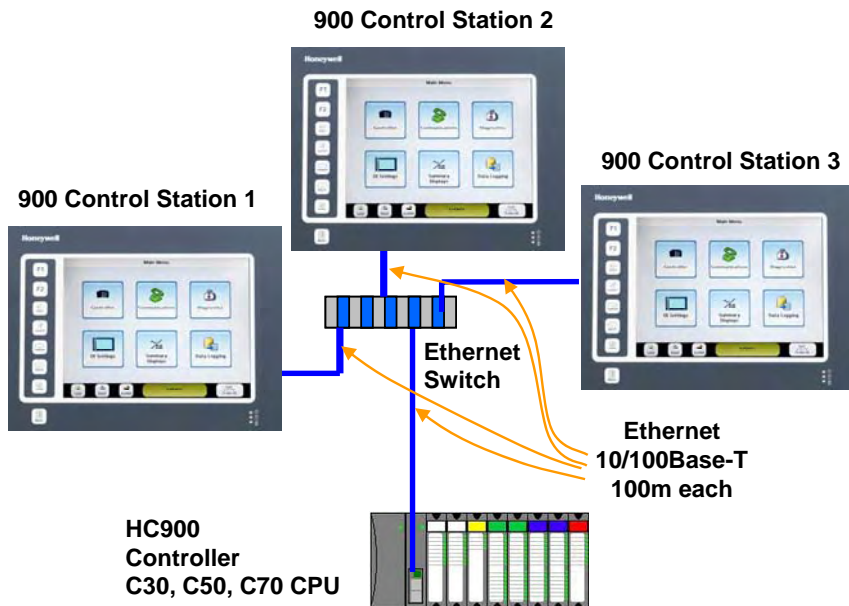

Up to 3 Control Stations may be connected to a HC900 controller using Ethernet. Multiple stations via RS 485 is not supported.

Cables

Ethernet



Ethernet communications are recommended for best performance.

Use shielded CAT5 cable (Honeywell part no. 514514032). Cable length must be less than 100 meters. For longer distances use Ethernet switches between cables. The use of Ethernet cables in excess of 100 meters may cause transmission delays that could have adverse affects on performance.

RS485

For RS485 between Control Station and HC900, construct a cable as follows.

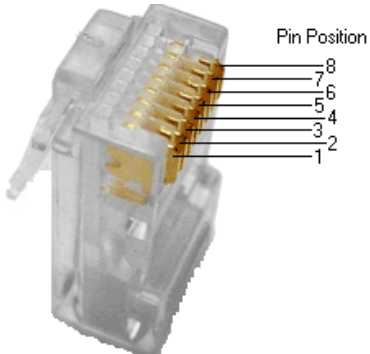
1. Cut off one connector of the shielded CAT5 cable.
2. Connect the wires indicated to the 3-plug connector that was supplied with the HC900 CPU module. See table below.

Shielded CAT5 cable		3-plug connector	
			
Signal	Pin		Terminal
Shield (aluminum-polyester foil tape with 26 AWG stranded drain wire)		Connect to	1
TXA	2	Connect to	2
TXB	1	Connect to	3
RXA	3		
RXB	4		
TXEN	5		
Common	6		
TXB	7	Connect to	3
TXA	8	Connect to	2

3. Cut off any unused wires in the cable and insulate with heat shrink tubing or other appropriate insulating material.

This connector plugs into the HC900's RS485 port; the RJ45 connector plugs into the Control Station's RS485 port.

RS232 Communications

If using RS232 communications to have the station communicate with other Honeywell or Modbus-compatible equipment, create a communications cable as follows.

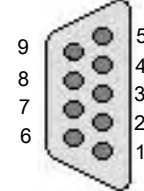
RJ12 connector		Connector of slave device	
			
Terminal no.	Signal	Terminal no.	Signal
1	CTS	7	RTS
2	RX	3	TXD
3	Ground	5	Ground
4	Ground	1	DCD
5	TX	2	RXD
6	RTS	8	CTS

If you are replacing a 559 or 1042 Operator Interface



EXPLOSION HAZARD

Do not connect or disconnect cables unless power has been switched off or the area is known to be non-hazardous. Failure to do so may result in death or serious injury.

Step	Action
1	Remove the power and communication wires from the 1042/559 operator interface. If the existing external 24Vdc power supply is rated at 1.21A (29W) or more, you can keep it to use with the Control Station.
2	Remove the operator interface from the panel.
3	If replacing 559, skip remaining steps below and return to page 3 step 1 (cut panel hole). If replacing 1042, proceed to step 4 below.
4	Extend existing panel opening by cutting it to 14.88 inches (378 mm) wide by 9.5 inches (241.3 mm) high.
5	<p>Order Honeywell Adapter Plate (part no. 50039118-501). Or construct an adapter plate as follows.</p> <p>Using 0.125 inch (3.17 mm) thick steel, construct adapter panel with outer dimensions, cutout, and holes as shown below. Drill holes using a 3/16 inch (4.76mm) size drill bit.</p>
6	Measuring carefully, draw a rectangle 1 inch (25.4mm) around the panel opening from step 4. Rectangle should measure 16.88 (428.7) x 11.5 (292.1). You will use this rectangle to center the adapter plate over the panel opening.
7	Align the adapter plate with the rectangle you just drew and mark the location of the 8 outside mounting holes on the existing panel. Drill 8 holes at these locations using a 3/16 inch (4.76mm) size drill bit.
8	Attach adapter panel through the 8 outer holes using eight #8-32 x 3/4" Phillips pan head screws and eight #8-32 hex nuts with integral lock washers.

Step	Action
9	Resume Mounting step 2 on page 3.

Specifications

<p>Environmental</p>	<p>Operating Temperature Range: 0 to 50 °C (32 to 122 F)</p> <p>Storage Temperature Range: -20 to 70 °C (-4 to 158 °F)</p> <p>Operating and Storage Humidity: 80% maximum relative humidity (non-condensing) from 0 to 50°C.</p> <p>Vibration According to IEC 68-2-6: 10 to 55 Hz, in X, Y, Z direction for 1.5 hours, 1 g.</p> <p>Shock According to IEC 68-2-27: Operational 30 g, 9 msec in 3 directions.</p> <p>Ingress: Type 4X Indoor, IP66 front panel protection</p> <p>Altitude: Up to 2000 meters.</p>																							
<p>Safety</p>	<p>EN 61010-1 – 2001. CE Mark requirements for General Purpose (Ordinary Location) Safety.</p> <p>ANSI/UL 61010-1 – 2004, Second Edition. General Purpose (Ordinary Location) Safety.</p> <p>CSA C22.2 No. 1010-1-2004- Second Edition. General Purpose (Ordinary Location) Safety.</p> <p>Type 4X Indoor use only enclosure rating (face only), UL50.</p> <p>IP66 Enclosure rating (face only), IEC529.</p> <p>IEC61326 - 2005 CE Mark EMC requirements for electrical equipment for measurement, control and laboratory use.</p>																							
<p>Electromagnetic Compatibility</p>	<p>Immunity to Industrial Locations:</p> <table border="0" data-bbox="438 936 1420 1510"> <tr> <td data-bbox="438 936 813 1010">ESD</td> <td data-bbox="813 936 1021 1010">IEC 61000-4-2</td> <td data-bbox="1021 936 1420 1010">Criterion A 4kV contact discharge 8kV air discharge</td> </tr> <tr> <td data-bbox="438 1032 813 1095">EM field</td> <td data-bbox="813 1032 1021 1095">IEC 61000-4-3</td> <td data-bbox="1021 1032 1420 1095">Criterion A 10 V/m</td> </tr> <tr> <td data-bbox="438 1117 813 1223">Electrical Fast Transient/Burst</td> <td data-bbox="813 1117 1021 1223">IEC 61000-4-4</td> <td data-bbox="1021 1117 1420 1223">Criterion A 2kV power 2kV I/O signal/control, including functional earth lines</td> </tr> <tr> <td data-bbox="438 1244 813 1351">Surge</td> <td data-bbox="813 1244 1021 1351">IEC 61000-4-5</td> <td data-bbox="1021 1244 1420 1351">Criterion B 1kV L-L, 2kV L-Gnd power 1kV I/O signal/control, including functional earth lines</td> </tr> <tr> <td data-bbox="438 1372 813 1436">Conducted RF</td> <td data-bbox="813 1372 1021 1436">IEC 61000-4-6</td> <td data-bbox="1021 1372 1420 1436">Criterion A 3Vrms Power and all I/O</td> </tr> <tr> <td data-bbox="438 1457 813 1521">Magnetic field</td> <td data-bbox="813 1457 1021 1521">IEC 61000-4-8</td> <td data-bbox="1021 1457 1420 1521">Criterion A 30A/m</td> </tr> </table> <p>Emissions:</p> <table border="0" data-bbox="438 1606 1420 1659"> <tr> <td data-bbox="438 1606 813 1659">Emissions</td> <td data-bbox="813 1606 1021 1659">EN 55011 (CISPR11)</td> <td data-bbox="1021 1606 1420 1659">Class A</td> </tr> </table>			ESD	IEC 61000-4-2	Criterion A 4kV contact discharge 8kV air discharge	EM field	IEC 61000-4-3	Criterion A 10 V/m	Electrical Fast Transient/Burst	IEC 61000-4-4	Criterion A 2kV power 2kV I/O signal/control, including functional earth lines	Surge	IEC 61000-4-5	Criterion B 1kV L-L, 2kV L-Gnd power 1kV I/O signal/control, including functional earth lines	Conducted RF	IEC 61000-4-6	Criterion A 3Vrms Power and all I/O	Magnetic field	IEC 61000-4-8	Criterion A 30A/m	Emissions	EN 55011 (CISPR11)	Class A
ESD	IEC 61000-4-2	Criterion A 4kV contact discharge 8kV air discharge																						
EM field	IEC 61000-4-3	Criterion A 10 V/m																						
Electrical Fast Transient/Burst	IEC 61000-4-4	Criterion A 2kV power 2kV I/O signal/control, including functional earth lines																						
Surge	IEC 61000-4-5	Criterion B 1kV L-L, 2kV L-Gnd power 1kV I/O signal/control, including functional earth lines																						
Conducted RF	IEC 61000-4-6	Criterion A 3Vrms Power and all I/O																						
Magnetic field	IEC 61000-4-8	Criterion A 30A/m																						
Emissions	EN 55011 (CISPR11)	Class A																						

Warranty/Remedy

Honeywell warrants goods of its manufacture as being free of defective materials and faulty workmanship. Contact your local sales office for warranty information. If warranted goods are returned to Honeywell during the period of coverage, Honeywell will repair or replace without charge those items it finds defective. The foregoing is Buyer's sole remedy and is **in lieu of all other warranties, expressed or implied, including those of merchantability and fitness for a particular purpose**. Specifications may change without notice. The information we supply is believed to be accurate and reliable as of this printing. However, we assume no responsibility for its use.

While we provide application assistance personally, through our literature and the Honeywell web site, it is up to the customer to determine the suitability of the product in the application