

Honeywell

SLATE™

Rectification Ampli-Check Flame Amplifier

R8001V1031

INSTALLATION INSTRUCTIONS

Rectification
Ampli-Check



Select

Reset

a 1

b 2



Scan for more information

Application

SLATE™ brings configurable safety and programmable logic together into one single platform. The platform can easily be customized for almost any requirement or application—offering virtually limitless development opportunities with far less complexity.

The R8001V1031 Rectification Ampli-Check module responds to a rectified signal from a rectification type flame detector to indicate the presence of flame. This flame amplifier is used with the C7000X detector series.

Features

- Module display for flame signal strength
- 0.0 to 20.0 VDC flame signal strength reading range

Specifications

Electrical Ratings:

Base Voltage and Frequency

- 24 VDC ($\pm 15\%$),
- 24 VAC ($\pm 15\%$), 50/60 Hz,
- 85–264 VAC, 50/60 Hz

Environmental Ratings:

Ambient Temperature:

- Operating: -20°F to $+150^{\circ}\text{F}$ (-29°C to $+66^{\circ}\text{C}$).
- Shipping: -40°F to $+150^{\circ}\text{F}$ (-40°C to $+66^{\circ}\text{C}$).

Humidity: 95% continuous, noncondensing.

Vibration: 0.5G environment

Dimensions: See Fig. 1.

Weight: 2 lb 1 oz (0.94 Kg)

Approvals

Underwriters Laboratories Inc. Listed, File: MP268

IRI Acceptable

Federal Communications Commission: Part 15, Class A

Must be mounted inside a grounded metal enclosure.

Mounting

DIN Rail (See Fig. 3)

Required Components

R8001A1001 Base Module

R8001S9001 Sub-base Assembly

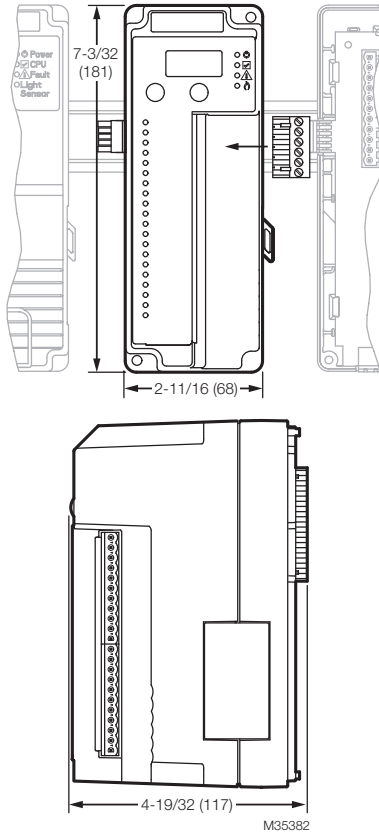

Fig. 1. Mounting dimensions of Rectification Ampli-Check Flame Amplifier in in. (mm).

Principal Technical Features

The R8001S1071 UV Ampli-Check module responds to a rectified signal from a rectification type flame detector to indicate the presence of flame. This flame amplifier is used with the C7027 and C7035 detector series.

LED Array

There are four LEDs on the front of the Ampli-Check Flame Amp module that provide quick identification of the system status and any problems that might occur. The status is broadcast to other modules on the platform bus in case they are affected by the inoperable modules. See Table 1 for descriptions.





LED	Color	Description
 Power	No light	System does not have power
	Green	System has power
 CPU	Red	No wire sheet or problem with the wire sheet
	Green	Running
 Fault	Red	SLATE Burner Control Module has detected a fault
	No light	Running
 Flame	Yellow	Weak flame is detected
	No light	No flame is detected

Table 1. LED Descriptions.

LED Display

The SLATE system modules have a seven-segment, three-position LED display used for indicating the module number of the SLATE system. The LED colors indicate the terminal state as shown in Table 2.

Color	Description
Terminal T2	
Green	Communicating with burner
Red	Communication fault
Terminal T8	
Green	Flame
Off	No flame

Table 2. Terminal LED Meanings.

Select and Reset Buttons

The SLATE system modules have Select and Reset buttons located on the front of the module and beneath the segment display. The Reset button is used to clear a lockout and reset the module. The Select button is used to scroll through the segment display information.

Selector Switch

The SLATE Burner Control Module is designed to operate with only one Flame Amplifier Module. The Flame Amplifier Module has a rotary switch on its back side which is factory set to 1. It must be set to 1 for the system to operate properly. See Fig. 2.

Installation



WARNING

Fire or Explosion Hazard

Can cause severe injury, death, or property damage.

Verification of safety requirements must be performed each time a control is installed on a burner to prevent possible hazardous burner operation.

When Installing This Product

1. Read these instructions carefully. Failure to follow them could damage the product or cause a hazardous condition.
2. Check the ratings given in the instructions and on the product to make sure the product is suitable for your application.
3. After installation is complete, check out the product operation as provided in these instructions.
4. The SLATE module must be mounted in an electrical enclosure with adequate clearance for servicing, installation and removal of modules.



WARNING

Electrical Shock Hazard.

Can cause severe injury, death or equipment damage.

1. Disconnect the power supply before beginning installation to prevent electrical shock and equipment damage. More than one power supply disconnect can be involved.
2. Verify the Selector Switch is set to 1. See Fig. 2.

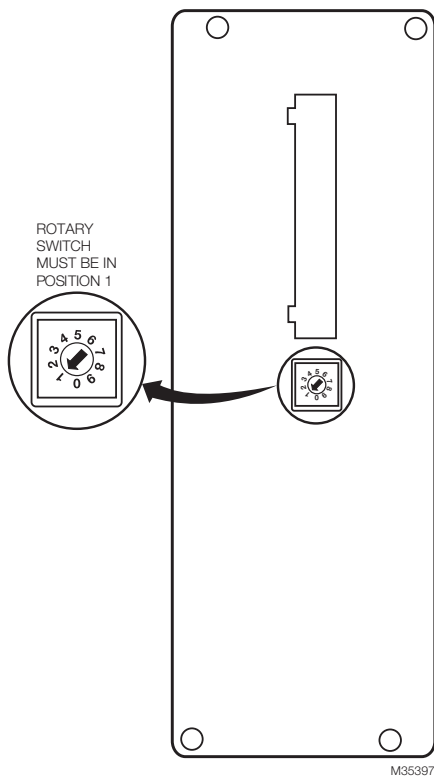
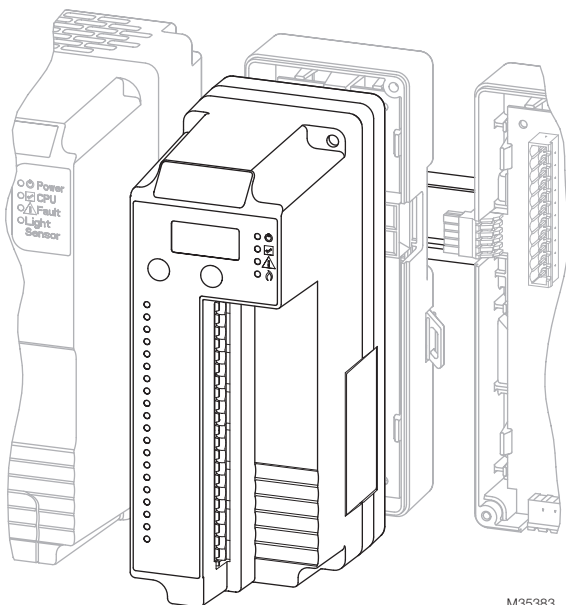

Fig. 2. Flame Amplifier Module Selector Switch.

3. Install the Flame Amplifier on the Sub-Base. See Fig. 3.



M35383

Fig. 3. Installing the Rectification Ampli-Check Flame Amplifier on the Sub-Base Module.

IMPORTANT

1. *Wiring must comply with all applicable codes, ordinances and regulations.*
2. *Wiring must comply with NEC Class 1 (Line Voltage) wiring.*
3. *The R8001V1031 should not interfere with the propersafety operation of the controls, limits and interlocks it is monitoring. After installation, check each control, limit and interlock to ensure that it is operating properly. DO NOT PLACE JUMPER WIRES ACROSS THE INSTALLATION CONTROLS, LIMITS AND INTERLOCKS.*
4. *G terminal on the flame amplifier must be connected to earth ground.*



CAUTION

Equipment Damage Hazard.

Incorrect combination of relay module, amplifier and flame detector can cause equipment damage.

Installing the Flame Detector

Proper flame detector installation is the basis of a safe and reliable flame safeguard installation. Refer to the instructions packed with the flame detector and the equipment manufacturer instructions.

Keep the flame signal leadwires as short as possible from the flame detector to the SLATE system. Capacitance increases with leadwire length, reducing the signal strength. The maximum permissible leadwire length depends on the type of flame detector, leadwire and conduit. However, the ultimate limiting factor for the flame detector leadwire is the flame signal.

If the flame amplifier is mounted on the DIN rail, it must be placed immediately to the right of the Burner Control Module that it is communicating with.

If the flame amplifier is not placed immediately to the right of the Burner Control Module, then it must be externally wired to it via the remote bus connections.

Wiring

1. Refer to Fig. 4 for proper flame detector wiring.
2. Disconnect power supply before making wiring connections to prevent electrical shock and equipment damage.

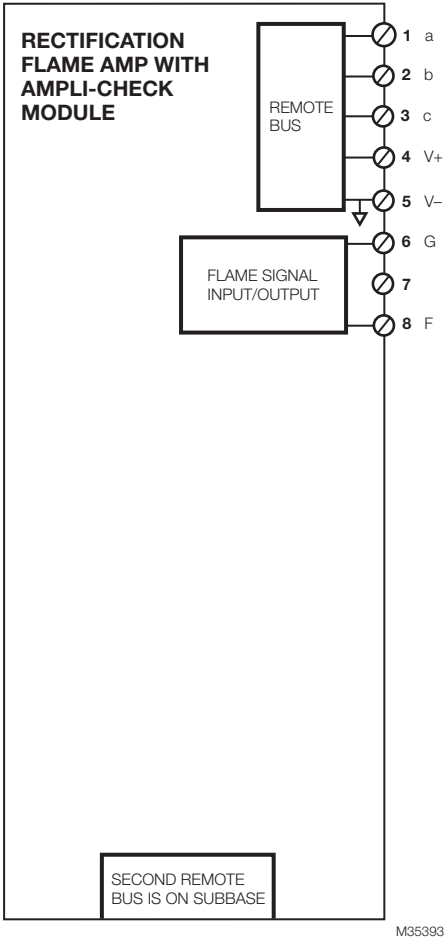

Fig. 4. R8001V1031 SLATE Rectification Ampli-Check Flame Amplifier wiring.

- 3.** All wiring must comply with appropriate electrical codes, ordinances and regulations including NEC Class 1 (Line Voltage) wiring where required.
- 4.** Use recommended wire size and type no. 18 copper conductors TTW (60C) or THW (75C) or THNN (90C).
- 5.** Use recommended wire routing:
 - a.** Keep the flame signal leadwire as short as possible from the detector to the SLATE module. The maximum permissible leadwire length depends on the type of leadwire, conduit type and leadwire diameter. The ultimate limiting factor for flame signal length is the flame signal voltage.
 - b.** Do not run high voltage ignition transformer wires in the same conduit with the flame detection wiring.
 - c.** If the flame detector leadwires are not long enough to reach the SLATE electrical connectors, make splices in a junction box.
 - (1)** Enclose scanner wiring without armor cable in metal cable or conduit.
 - (2)** Follow flame detector Instructions.
- 6.** Check wiring, see Fig. 4.

Checkout

Preliminary Inspection

Make certain that:

1. Wiring connections are correct and all terminal screws and electrical connections are tight.
2. Proper flame failure response time is selected.
3. Amplifier is securely mounted on the DIN Rail and bus connector secured to SLATE Burner Control Module.
4. Detectors are properly positioned and cleaned according to Detector Instructions.
5. Correct combination of amplifier and flame detector is used.

NOTE: R7824C, Series 2 or greater, pulse shutter when signal of 1.5 Vdc is sensed. Display readings of 0.7 to 2.4 Vdc are common.

The flame signal for the pilot alone, the main burner flame alone, and both together must be steady and a minimum of 0.8V. If the flame signal is unsteady, or less than the minimum acceptable voltage, check the flame detector installation and circuitry in the following procedure.

1. Check the supply voltages. Make sure the master switch is closed, connections are correct, and the power supply is of the correct voltage and frequency and is sinusoidal.
2. Check the detector wiring for defects including:
 - a. Incorrect connections.
 - b. Wrong type of wire.
 - c. Deteriorated wire.
 - d. Open circuits.
 - e. Short circuits.
 - f. Leakage paths caused by moisture, soot or accumulated dirt.
3. For a flame rod, make sure:
 - a. There is enough ground area.
 - b. The flame rod is properly located in the flame.
 - c. Temperature at the flame rod insulator is no greater than 500°F (260°C).

4. With the burner running, check the temperature at the detector. If it exceeds the detector maximum rated temperature:
 - a. Add a heat block to stop conducted heat traveling up the sight pipe.
 - b. Add a shield or screen to reflect radiated heat.
 - c. Add cooling (refer to sight pipe ventilation in the detector Instructions).
5. Make sure that the flame adjustment is not too lean.
6. Make sure the optical detector is properly sighting the flame.
7. If necessary, resight or reposition the detector.
8. If you cannot obtain proper operation, replace the plug-in amplifier.
9. If you cannot yet obtain proper operation, replace the flame detector.

IMPORTANT

If you make any changes to the flame detection system, repeat all required Checkout tests in Checkout section of the Instructions for the applicable SLATE module.



32-00024-01

For more information and detailed instructions on the R8001V1031 and the entire SLATE system please refer to the SLATE User Guide located on our website at <http://combustion.honeywell.com/SLATE>

Honeywell

Automation and Control Solutions

Honeywell International Inc.
1985 Douglas Drive North
Golden Valley, MN 55422
customer.honeywell.com

® U.S. Registered Trademark.
© 2014 Honeywell International Inc.
32-00024—01 M.S. 12-14
Printed in U.S.A.