

A SANITARY PROCESS REFRACTOMETER FOR BRIX AND CONCENTRATION MEASUREMENT

K-PATENTS
PROCESS INSTRUMENTS



K-PATENTS SANITARY PROCESS REFRACTOMETER PR-23-A

TYPICAL APPLICATIONS

FOOD

Confectionary, candies, caramel, fudge, flavors, toffee, syrup, topping, sugar coating. Dairy products, condensed milk, skimmed milk, milk powder, caseinate, yeast extract, yoghurt, whey. Egg, egg yolk, egg white. Preserves, canned fruits, canned vegetables, sauces, instant soups. Soy, soy milk. Tomato based products, tomato puree, ketchup.

BEVERAGE

Alcohol, rum, molasses, liquors, cider. Beer, wort, cut beer. Juices, blended fruit juices and nectars, juice concentrate, ice tea, ice coffee, instant coffee, instant tea. Soft drinks, energy and sport drinks, beverage base. Wines, grape must.

FRUITS AND BERRIES PREPARATION

Jams, jellies, marmalades, preserves and all types of product combinations of fruit, flavors, pectin, acid and sugar (liquid and crystal sugar), apples, pears, pineapples, grapes, plums, strawberries, blueberries, raspberries, cranberries, gooseberries, cherries and more.

STARCH SWEETENERS

Sucrose, high fructose corn syrup, sorbitol, dextrose, glucose, xylose, maltose, mannitol, lactitol, aspartame, flavors. Supersaturation and seeding point control of fructose and dextrose syrups, cooling crystallizer, precrystallizer, main crystallizer.

SUGAR MOLASSES

Dilution and blending of beet and cane sugar molasses, desugarisation by chromatographic separation.



INSTALLATION

COMPACT SENSOR FOR SMALL PIPES

Pipe bend

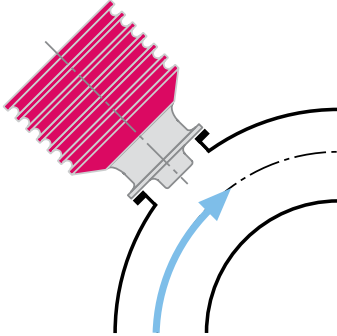

To keep velocity above 1.5 m/s

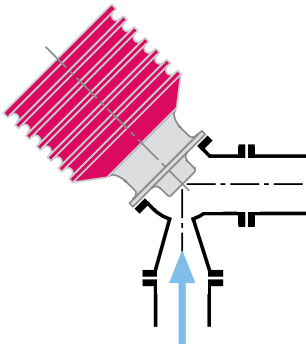

Small pipe

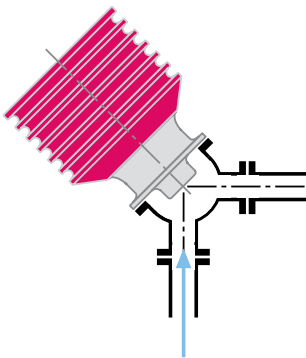

PROBE SENSOR FOR LARGE PIPES AND VESSELS

Large pipe

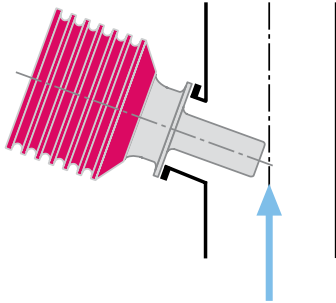

Vessel

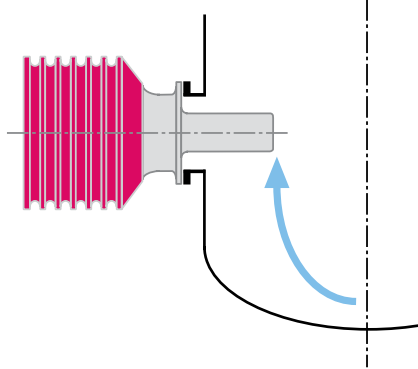

Cooker with scraper and steam jacket

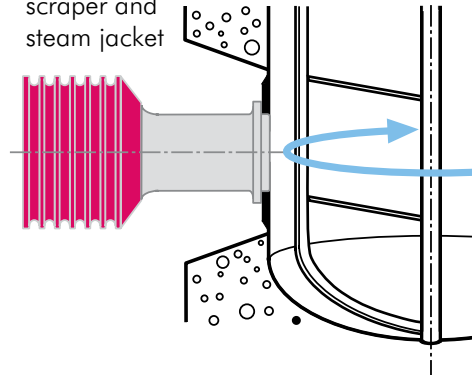

CALIBRATION

K-Patents Sanitary Process Refractometer PR-23-A sensor is factory calibrated to measure refractive index n_D and temperature T in standard units. Each sensor has identical calibration $n_D=1.31...1.54$ (corresponding to 0-100 Brix).

The non-linear conversion from refractive index to Brix or concentration units and also temperature compensation are based on standard tables. They are programmed inside the transmitter independently of the sensor. Therefore, all sensors are freely interchangeable.

K-Patents' manufacturing process is ISO 9001 certified. K-Patents also supports the verification within the user's own quality system.

Each sensor is provided with a calibration certificate comparing a set of standard liquids to the actual sensor output. Hence, the calibration and accuracy can be easily verified on-site with the certified refractive index liquids and K-Patents documented verification procedure.

DIGITAL MEASUREMENT PRINCIPLE

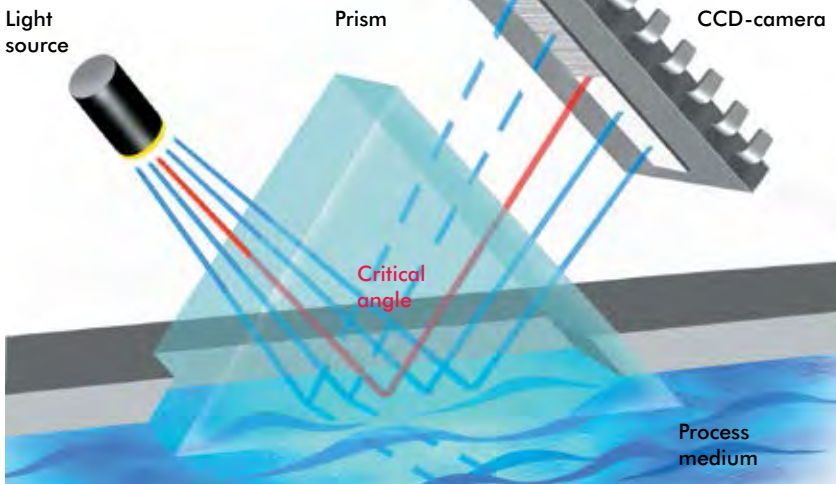

The light source emits light at the interface, between a prism and the process solution, where the rays meet the surface at different angles.

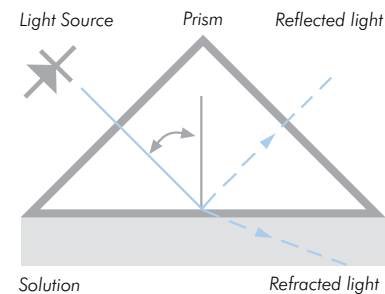

Depending on the angle, some rays undergo a total internal reflection. The rest of the light is refracted into the process solution.

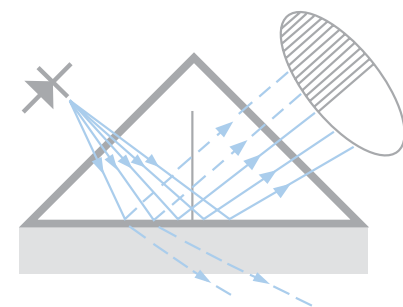

Thus an optical image with a dark sector and a light sector is created.

The angle corresponding to the shadow line is called the Critical Angle of Total Reflection. The Critical Angle is a function of the refractive index and hence the concentration of the solution.

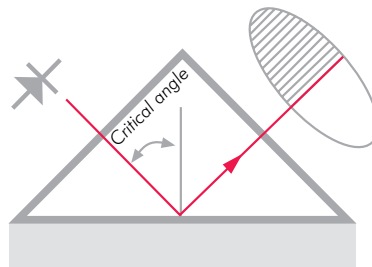

A digital CCD-camera detects the optical image and the shadow line. The camera transforms the optical image point-by-point to an electrical signal. The exact shadow line position is located and the refractive index n_D is determined.

A built-in temperature sensor measures the temperature T on the surface of the process liquid. The indicating transmitter converts the refractive index n_D and temperature T to concentration units.

The diagnostics program ensures that the measurement is reliable.

OPERATION

K-Patents Sanitary Process Refractometer PR-23-A is 3-A Sanitary Certified per Standard numbers 46-03 and 74-06, and it has received the 3-A Third Party Verification (TPV) certification. The 3-A certification guarantees that the K-Patents Sanitary Process Refractometer PR-23-A is easy to clean and inspect and it stays clean during the processing.

The PR-23-A provides truly accurate means for measuring liquid concentrations and Brix in various process applications. With K-Patents PR-23-A the product quality can be controlled precisely over the whole batch without costly sampling.

The measurement accuracy is not influenced by particles, bubbles, sugar crystals, seeds, fibres, colour or temperature changes in the process medium.

If desired, the measurement range and the measurement unit can be freely changed by keyboard entry. No mechanical adjustments or parts are needed. The change can be done, when the instrument is installed and operating.

The K-Patents PR-23-A does not require any recalibration or frequent maintenance.

DESIGN

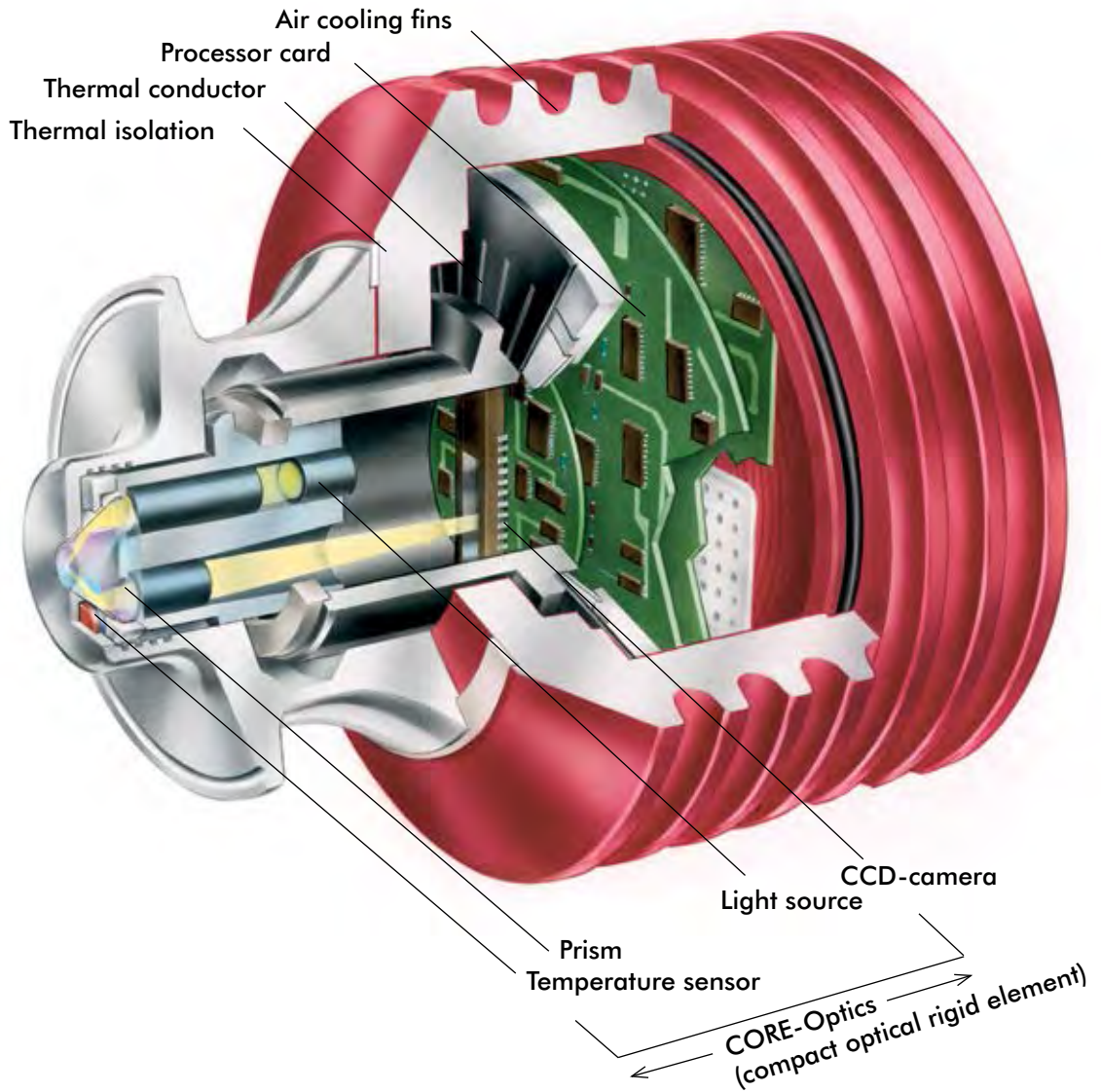

All measuring components are in one solid CORE-optics module. The patented CORE-optics is mechanically isolated from the influence of external forces and vibrations. The CORE-optics contains no mechanical adjustments.

SPECIFICATIONS

Compact sensor PR-23-AC for small pipe lines

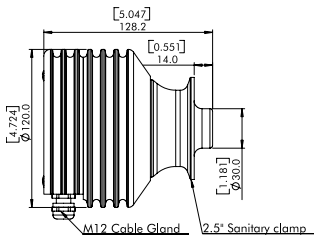

Probe sensor PR-23-APT/R for large pipe lines and vessels

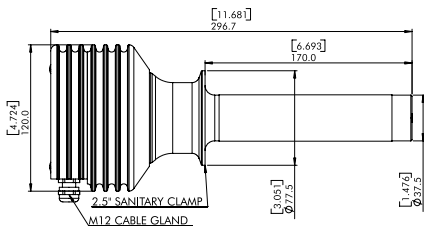

Probe sensor PR-23-AP-P for flush mounting on the vessel wall

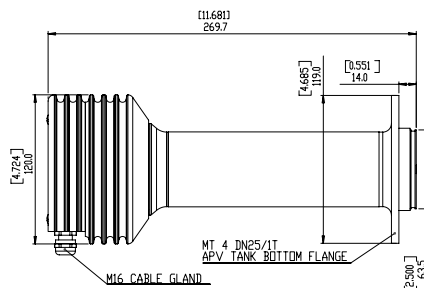

Indicating transmitter DTR

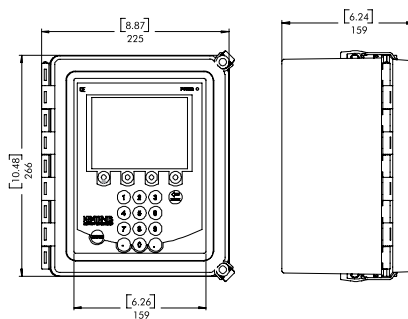

Refractive Index range:	Full range, $n_D = 1.3200...1.5300$ (corresponds to hot water...100 Brix)
Accuracy:	Refractive index $n_D \pm 0.0002$ (corresponds typically to $\pm 0.1\%$ by weight) Repeatability $n_D \pm 0.0001$ (corresponds typically to $\pm 0.05\%$ by weight)
Speed of response:	1 s undamped, damping time selectable up to 5 min
Calibration:	With Cargille standard R.I. liquids over full range of $n_D 1.3200...1.5300$
Patented CORE-Optics:	No mechanical adjustments and digital measurement with 3648 pixel CCD element, sodium D-line light emitting diode (LED), built-in Pt-1000 temperature sensor (linearization according to IEC 751)
Temperature compensation:	Automatic, digital compensation
Instrument verification:	With NIST traceable Cargille standard R.I. liquids. A transmitter guided procedure over Ethernet including a printable verification report
Ambient temperature:	Sensor: max. 45°C (113°F), min. -20°C (-4°F) Indicating transmitter: max. 50°C (122°F), min. 0°C (32°F)
SENSOR PR-23-A:	PR-23-AC Compact sensor model for small pipe lines PR-23-AP Probe sensor model for large pipe lines and vessels
Process connection:	PR-23-AC: Sanitary 3A-clamp 2.5"; Varivent® in-line access unit clamp DN65 or via elbow flowcell (for line sizes of 2.5" and smaller) PR-23-AP: Sanitary 3A-clamp 2.5"; Sanitary 3A-clamp 4" or MT4 DN 25/1T APV Tank bottom flange
Sanitary design:	3-A Sanitary Standard 46-03 and 74-06 approved and EHEDG (European Hygienic Equipment Design Group) tested
Process pressure:	Sanitary clamp max. 15 bar (200 psi) at 20°C (70°F)/9 bar (125 psi) at 120°C (250°F)
Process temperature:	PR-23-AC: -20°C...130°C (-4°F...266°F), PR-23-AP: -20°C...150°C (-4°F...302°F)
Process wetted parts, standard:	AISI 316L stainless steel, prism spinel, prism gaskets modified PTFE (Teflon)
Sensor protection class:	IP67, Nema 4X
Sensor weight:	PR-23-AC: 2.0 kg (4.4 lbs), PR-23-AP: 3.0 kg (6.6 lbs)

INDICATING TRANSMITTER DTR:

Display:	320x240 pixel graphical LCD with LED backlight
Keypad:	18 membrane keys
Current output:	Two independent current sources, 4-20 mA, max. load 1000 Ohm, galvanic isolation 1500 VDC or AC (peak), hold function during prism wash
Power:	AC input 100-240 VAC/50-60 Hz, optional 24 VDC
Ethernet connection:	10/100 Mbit/s, data acquisition over UDP/IP Protocol with data logging software
Alarms/Wash relays:	Two built-in signal relays, max. 250 V/3 A
Sensor connectivity:	One or two sensors can be connected to the DTR. Sensors independent of each other: own parameter sets and usable in different applications. Two current outputs configurable independently to indicate process concentration or temperature of either sensor.
Transmitter protection class:	Enclosure IP66, Nema 4X (Indoor use)
Indicating Transmitter weight:	4.5 kg (10 lbs)
INTERCONNECTING CABLE:	IEC 61158-2 compliant two-wire cable
Interconnecting cable length:	Standard 10 m (33 ft), max. 200 m (660 ft)
OPTIONS:	Stainless steel sensor housing, prism wash, cable fittings to the indicating transmitter: European cable glands M20x1.5 or US conduit hubs, Hazardous and intrinsic safety approvals for hazardous area installations.
PATENTS:	See www.kpatents.com

ORDERING INFORMATION:

- Sensor type and process connection
- Desired scale
- Properties of process solution
- Process temperature range
- Process pressure range
- Length of interconnecting cable
- Supply voltage and frequency
- Options and accessories

K-PATENTS OY

P.O. BOX 77
ELANNONTIE 5
FI-01511 VANTAA, FINLAND
PHONE: INT.+358-207-291 570
FAX: INT.+358-207-291 577
INFO@KPATENTS.COM
WWW.KPATENTS.COM

K-PATENTS, INC.

1804 CENTRE POINT CIRCLE, SUITE 106
NAPERVILLE, IL 60563
U.S.A.
PHONE: (630) 955 1545
FAX: (630) 955 1585
INFO@KPATENTS-USA.COM
WWW.KPATENTS.COM

We reserve right to technical alterations.