

HPW7000 Hi-pHurity Water Measurement System Operation and Maintenance Manual

70-82-25-75

Rev 0

11/98

Copyright, Notices, and Trademarks

Printed in U.S.A. – © Copyright 1998 by Honeywell Inc.

Revision 0 – 11/98

While this information is presented in good faith and believed to be accurate, Honeywell disclaims the implied warranties of merchantability and fitness for a particular purpose and makes no express warranties except as may be stated in its written agreement with and for its customer.

In no event is Honeywell liable to anyone for any indirect, special or consequential damages. The information and specifications in this document are subject to change without notice.

Honeywell
Industrial Automation and Control
Automation College
2820 West Kelton Lane
Phoenix, AZ 85023
(602) 313-5669

About This Document

Abstract

The purpose of this manual is to support the installation, operation and maintenance of the High Purity Electrode Mounting Assembly.

Revision Notes

The following list provides notes concerning all revisions of this document.

Rev. ID	Date	Notes
0	11/98	This document is the initial release for a new product.

References

Honeywell Documents

The following list identifies all Honeywell documents that may be sources of reference for the material discussed in this publication.

Document Title	ID #	Binder Title	Binder ID #
----------------	------	--------------	-------------

Non-Honeywell Documents

The following list identifies select non-Honeywell documents that may be sources of reference for the material discussed in this publication.

Title	Author	Publisher	ID/ISDN #
-------	--------	-----------	-----------

Contacts

The following list identifies important contacts within Honeywell.

Organization	Telephone	Address
Honeywell TAC	1-800-423-9883 Voice	1100 Virginia Drive Fort Washington, PA 19034

Contents

1.	INTRODUCTION.....	1
1.1	General.....	1
1.2	Description.....	1
1.3	Features.....	1
2.	SPECIFICATIONS AND MODEL SELECTION GUIDE.....	3
2.1	Specifications	3
2.2	Model Selection Guide	4
3.	INSTALLATION.....	7
3.1	Overview – Panel Mounted.....	7
3.2	Overview – Customer Supplied Mounting.....	8
3.3	Unpacking.....	8
3.4	Mounting the Assembly.....	8
3.4.1	Mounting Procedure.....	8
3.4.2	Electrode Procedure	9
3.5	Wiring.....	11
4.	OPERATION	13
4.1	Overview.....	13
4.2	Calibration.....	13
4.2.1	Procedure	13
5.	MAINTENANCE	15
5.1	Overview.....	15
5.2	Cleaning.....	15
5.3	Electrode Removal and Installation	15
5.3.1	Reference Electrode Removal.....	15
5.3.2	Reference Electrode Installation	15
5.3.3	Measuring Electrode Removal.....	16
5.3.4	Measuring Electrode Installation	16
5.4	Replacement Parts List.....	16

Figures

Figure 1-1 High Purity Electrode Mounting Assembly (Panel Mounted Option)	2
Figure 3-1 Unit with Parts Called Out.....	7
Figure 3-2 Unit Showing Assembly (Panel Mounted Option).....	10
Figure 3-3 Wiring Diagram.....	11
Figure 5-1 Sensor Assembly	17

1. Introduction

1.1 General

The HPW7000 Hi-pHurity Water Measurement System is an electrode mounting assembly designed specifically for the difficult pH measurement in high purity water applications. The special flow chamber and electrode mounting simplifies installation and calibration while providing a pH measurement that is unsurpassed in accuracy and stability.

1.2 Description

The HPW7000 combines a specially designed 316L stainless steel flow chamber with a measuring/reference electrode system and integral temperature sensor/solution ground. This mounting assembly provides accurate and stable pH measurement in low conductivity (<10 μ Siemen/cm) water.

The specially designed flow chamber optimizes the sample flow volume and creates the proper flow and mixing patterns to make the most accurate and stable pH measurement. In addition, the assembly installation is foolproof. The flow chamber cover is keyed and the electrode position is fixed so that the user will continue to get the same superior measurement results every time a calibration or replacement is done. A quick opening clamp holds the flow chamber top in place in the flow chamber. Removing and re-installing the electrodes for calibration is quick and easy with this clamp mechanism.

A flowing reference electrode is used to provide high accuracy and minimize calibration-offset errors. A new flowing reference electrode design provides superior performance in low ionic strength media. This makes the mounting more streamline in water sample panels where space is at a premium.

Electrode cables that can be up to 36 feet in length eliminate the need for mounting preamplifiers on the assembly. All electrode terminations are internal to the analyzer and are protected by the analyzer case. The electrode cables are all shielded to reduce the susceptibility to noise and make the measurement more stable.

1.3 Features

- Designed for high purity water applications, <10 μ Siemen/cm conductivity
- Easy to install and assures correct operation and maximum performance
- Reduces calibration and maintenance time & cost with a quick disconnect clamp that allows the electrode assembly to be easily removed without tools or special instructions
- Lower maintenance cost with a new reference electrode that's easy to fill and maximizes the time between re-fills
- Unsurpassed stability
- Minimal long term drift
- Minimizes calibration errors
- Small assembly that can be panel or surface mounted
- Sample flows 50-500 cc/min

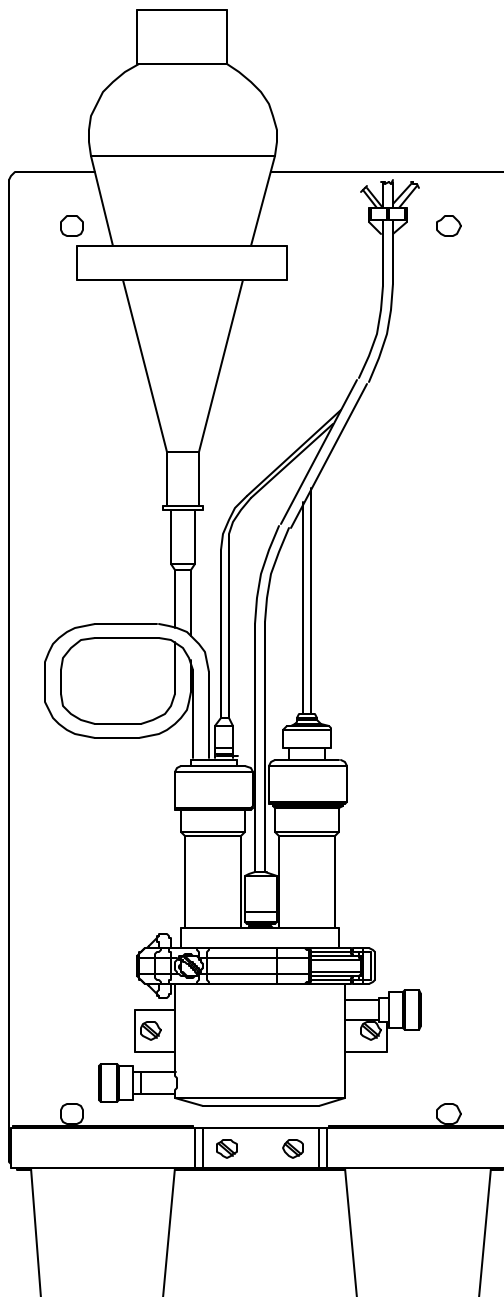

Figure 1-1 High Purity Electrode Mounting Assembly (Panel Mounted Option)

2. Specifications and Model Selection Guide

2.1 Specifications

pH Range (operating)	0 — 14 pH (4 to 10 pH)
Temperature Sensor	-20 to 150°C
Temperature: Assembly Electrodes	10 to 45°C 10 to 80°C
Conductivity Range	< 10 µmhos/cm
Accuracy	±0.1 pH
Noise	<0.1 pH
Stability/Drift	±0.1 pH/wk
Preamp	In 9782 or 7082 pH Analyzer
Process Connection	1/4" male - side mounted on flow assembly
Pressure Downstream back pressure	-10" W.C. (min.), +1.0" W.C. (max.)
Flow Assembly	316LSS
Electrode Covers	316LSS
Finish	150 grit polish minimum

2.2 Model Selection Guide

Section 2.2 lists the model number with appropriate Tables 1 through 5, which completely describe the equipment according to the following:

INSTRUCTIONS

HPW7000 Mounting Assembly Includes:

- Stainless Steel Flow Chamber with Electrode Mounting Cover
- ¼” Inlet/Outlet Process Connections
- Glass Measuring Electrode (P/N 31117390)
- Flowing Reference Electrode (P/N 51198296-001)
- Combined Temperature Sensor/Solution Ground
- Flowing Reference Reservoir and Connections
- Stainless Steel Electrode Covers

* Select the desired key number. The arrow to the right marks the selection available.

* Make one selection from Table I using the column below the proper arrow

A dot (●) denotes unrestricted availability.

↔ **Key number** ↔ ↔ I ↔ ↔ II ↔ ↔ III ↔ ↔ IV ↔

Key Number	Avail	
Description		
Hi-pHurity High Purity Water pH Measurement System	HPW7000	-

Table I - Electrode System

Glass Measuring, Flowing Reference, Temp/Counter	01	-
Future		
Future		

Table II - Electrode Cable Lengths

20 foot cables	20	-
36 foot cables	36	-

Table III - Mounting Panel

No Mounting Panel	00	-
Mounting Panel Supplied	01	-

Table IV – Options

Tagging	None	0	-
	Linen Customer I.D. Tag, Limit to 3 Lines, 22 Spaces per Line	L	-
	Stainless Steel Customer I.D. Tag, Limit to 3 Lines, 22 Spaces per Line	S	-
Electrode Certificate of Calibration	No	00	-
	Yes	01	-

3. Installation

3.1 Overview – Panel Mounted (Table III = 01)

The Hi-pHurity Water pH Assembly comes completely assembled on a stainless steel panel, except for wiring to the pH analyzer. The electrodes are mounted in the flow chamber cover to the correct depth and orientation. The panel should be mounted using the four holes at the corners of the panel. Use 3/8”-16 (M8) diameter bolts, lockwashers, and nuts to mount the panel.

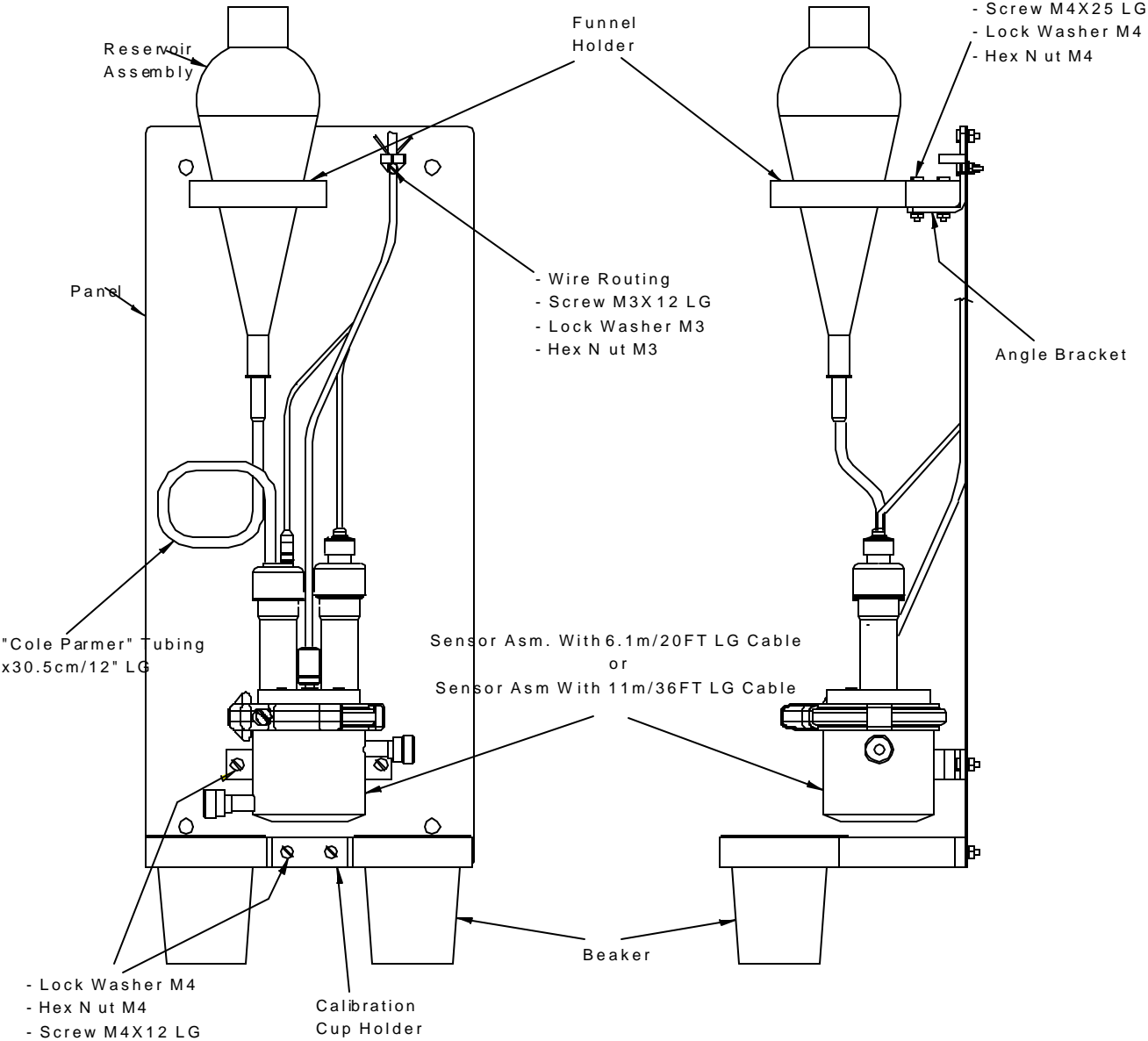

Figure 3-1 Unit with Parts Called Out

3.2 Overview – Customer Supplied Mounting (Table III = 00)

The Hi-pHurity Water pH Assembly also comes unmounted with a drawing detailing the general layout of the assembly. This allows the customer to work with the area available when mounting the assembly.

3.3 Unpacking

When unpacking the assembly, the following should be observed:

- The Reference Solution Reservoir is loose.
- The cables are already attached to the electrodes and are ready to be connected to the analyzer after the assembly has been mounted.
- A bottle of reference solution is included.
- There are 2 loose calibration cups. These should be removed and set aside in a convenient place until needed to calibrate the system before operation.

3.4 Mounting the Assembly

Before mounting the assembly the user should acquire the necessary mounting hardware that will be used to mount the assembly and the tubing that will connect to the sample source and the output drain. It is recommended that the screws used be 3/8-16 bolts with the length determined by the brackets. It is also recommended that the outlet tubing be clear so the customer will be able to determine if there is air in-leakage in the chamber.

3.4.1 Mounting Procedure

1. Mount panel with user supplied hardware. If the unmounted option was selected, mounting should be done in accordance with the drawing supplied.

CAUTION

All connections to the assembly should be tightened **finger tight** only. No wrenches are needed.

2. Insert Reference Solution Reservoir in supplied holder.
3. Remove black cap from the top of the Reference Electrode.
4. Pinch off end of tube from reservoir with thumb and forefinger.
5. Fill reservoir using supplied reference solution.
6. After filling reservoir, get rid of any air bubbles that may be in the tube by allowing reference solution to flow from the tube.
7. When all the air bubbles have been removed, pinch off the tube as in Step 4.
8. Push on the tube from reservoir to reference electrode spout.
9. Connect cables to analyzer following procedure in Section 3.4.
10. Connect sample source tubing to left lower inlet. Tighten finger tight only.
11. Connect outlet tubing out to drain (atmospheric pressure).

The assembly is now mounted correctly.

3.4.2 Electrode Procedure

1. Before the system can be used, the shipping boot must be removed from the reference electrode.
2. Remove clamp from flow chamber.
3. Lift out the electrode assembly cover.
4. Carefully remove the boot from the reference electrode.

WARNING

Extreme caution should be taken when removing the boot from the electrode. The electrode is made of glass and can be easily broken.

5. Re-install the electrode chamber cover, making sure that the gasket and the pin on the chamber align.
6. Re-install clamp.
7. Turn on sample flow.
8. Before calibrating, the system should acclimatize for 24 hours.

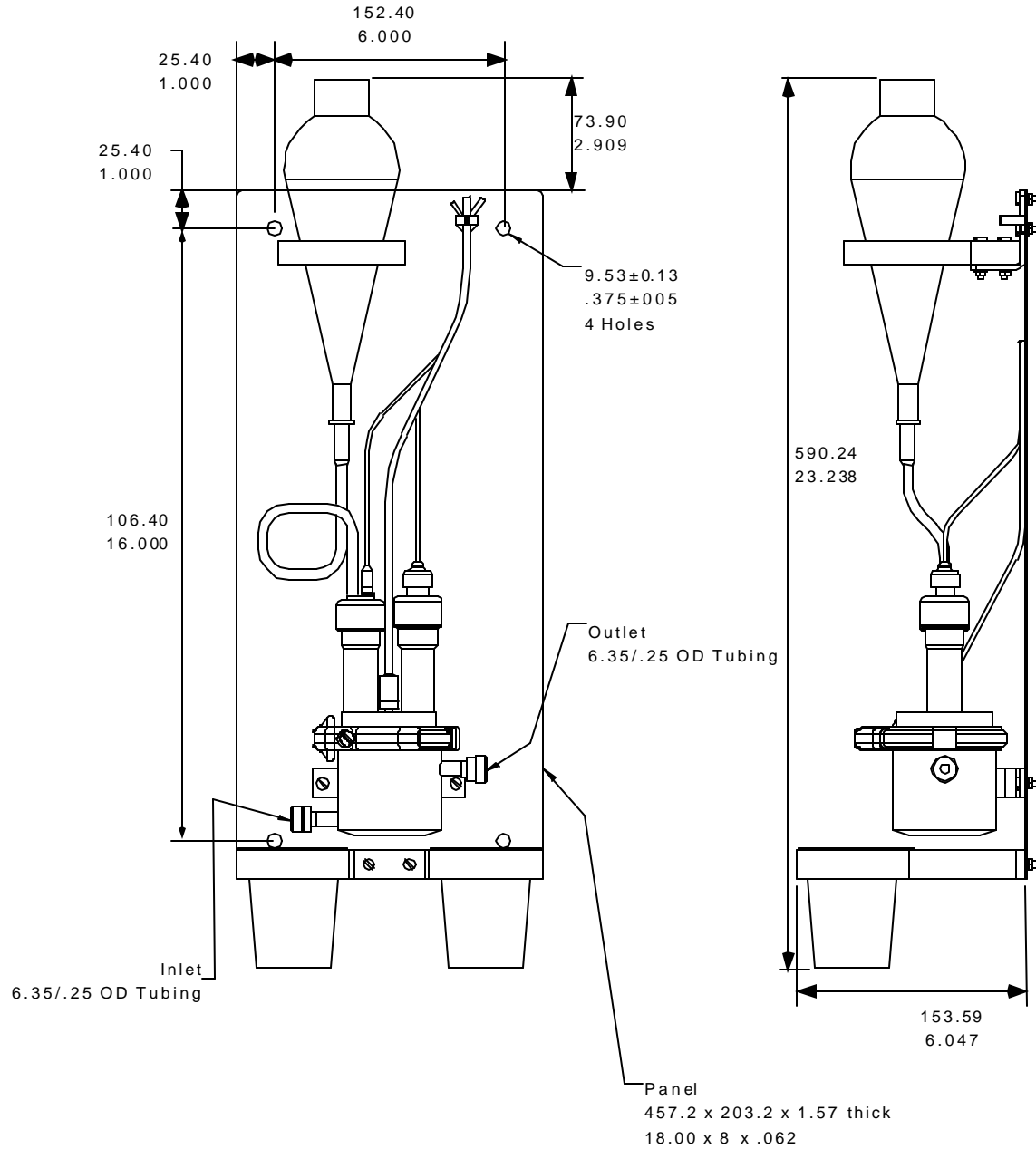

Figure 3-2 Unit Showing Assembly (Panel Mounted Option)

3.5 Wiring

The terminations on the cables for the measuring and reference electrodes and temperature sensor have push-on connectors (except the coax from the reference electrode). When wiring to the 9782 -04, High Purity Water Analyzer the terminals in the 9782-04 have the mating connector on the terminals. When wiring to an existing 9782-02 and 7082-3X, High Purity Water Analyzer, you must cut off the push-on connectors, skin and tin the leads and then wire to the screw terminals in the analyzer.

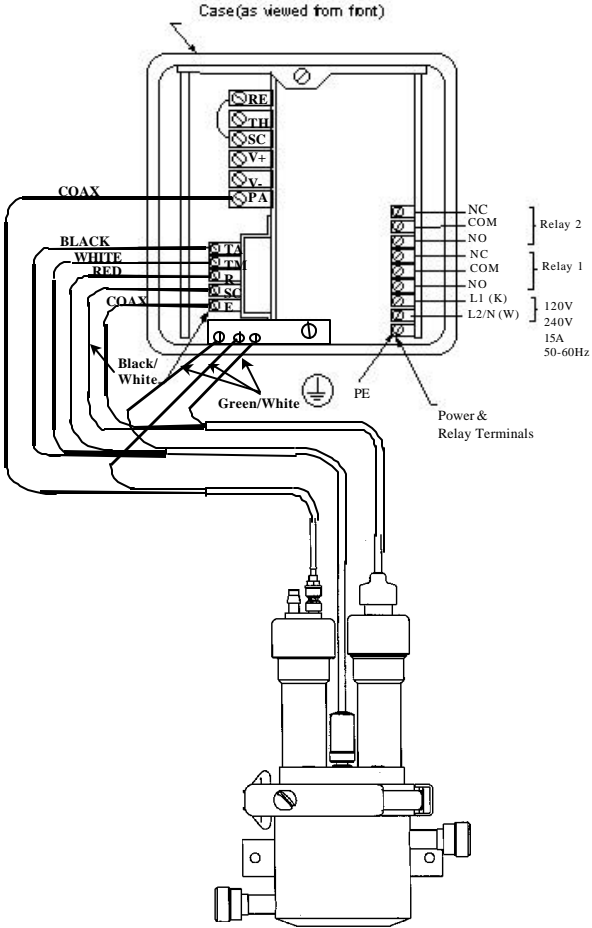

Figure 3-3 Wiring Diagram

4. Operation

4.1 Overview

To begin using the Hi-pHurity Water pH Measurement System the assembly needs to be mounted, wired, and then calibrated. No other special procedures needs to be performed prior to beginning operation.

4.2 Calibration

ATTENTION

Before calibration the system must be acclimated for 24 hours.

For best results, the Hi-pHurity Water Assembly electrode system should be calibrated at regular intervals. The frequency of calibration is determined by the user's experience for a particular installation.

A pH calibration consists of a Standardization (zero) and Slope (span) adjustment. The calibration procedure involves adjusting the displayed value of pH to agree with a known pH solution value. The known pH values are listed on or with the standard solutions. These standard solutions are commonly called buffers.

The procedure for making adjustments to the pH reading at the instrument is described in the instruction manual of the pH analyzer you are using. Please refer to the Analyzer directions for more information on calibration of the system.

4.2.1 Procedure

ATTENTION

Refer to your pH analyzer Instruction Book for additional information on calibration, especially for instructions on how to adjust reading when performing a standardize and slope calibration.

1. Turn sample flow off.
2. Select two buffer solutions. The buffer solutions must be at least 2 pH apart.
3. Place calibration cups in holders on the panel.
4. Fill each cup with a buffer solution up to 150 ml or almost full.
5. Provide enough cable slack to allow electrodes to reach the calibration cups.
6. Remove clamp that holds the top cover to the flow chamber.
7. Remove electrodes from flow chamber and place in first (Standardize) buffer.
8. Wait for pH reading to stabilize. Make adjustment to the pH value to match buffer value at the buffer temperature.
9. Place electrodes back in flow chamber to rinse.
10. Place in second (slope) buffer.
11. Wait for pH reading to stabilize. Make adjustment to the pH value to match buffer value at the buffer temperature
12. Place electrodes back in flow chamber.
13. Make sure the cover notch, gasket notch, and cover pin are all aligned.

14. Replace clamp.
15. Re-start sample flow to the flow chamber.

5. Maintenance

5.1 Overview

Maintenance consists of calibrating the system (see Section 4) and cleaning the electrodes. The interval between these operations depends upon the nature of the sample, whether it is clean or not, and the accuracy required.

5.2 Cleaning

Periodic cleaning of the electrodes may be required depending on the installation. If the system is shut down for a time rust and debris can collect in the pipes. When the system is started up again this debris can collect on the electrodes. To clean the electrodes remove them from the assembly and clean with distilled water and a mild detergent.

5.3 Electrode Removal and Installation

The measuring and reference electrode orientation and depth are important for the proper operation of the Hi-pHurity Water pH Assembly. The electrodes are shipped installed in the flow chamber cover. Occasionally these electrodes have to be removed for inspection, replacement, or cleaning. The proper reinstallation into the assembly is essential for accurate and reliable performance.

ATTENTION

Before beginning electrode replacement, make sure the flow to the flow chamber is stopped.

ATTENTION

There is an o-ring on the measuring and reference electrode. This o-ring must be re-used on a replacement electrode. Remove o-ring from existing electrodes and set aside to use on the replacement electrode.

5.3.1 Reference Electrode Removal

1. Remove cable from electrode.
2. Simultaneously twist and pull the reservoir tube from spout. When clear of spout, pinch off tube end.
3. Allow reservoir to drain into clean plastic container. The reference solution can be reused.
4. Remove electrode holder cap.
5. Loosen the electrode holder.
6. Remove electrode and place in one of the calibration holders.

5.3.2 Reference Electrode Installation

1. Wet the electrode body with DI water.
2. Replace 1 o-ring on electrode up to the shoulder.

3. Place electrode into electrode holder in top cover, marked “R”.
4. Tighten electrode holder finger tight.
5. Replace electrode holder cap and finger tighten.
6. Remove black cap from the top of the Reference Electrode.
7. Pinch off end of tube from reservoir with thumb and forefinger.
8. Fill reservoir using supplied reference solution.
9. After filling reservoir, get rid of any air bubbles that may be in the tube by allowing reference solution to flow from the tube.
10. When all the air bubbles have been removed, pinch off the tube as in Step 7.
11. Push on the tube from reservoir to reference electrode spout.
12. Wash off the top of the reference electrode with distilled water and wipe dry.
13. Re-connect the cable.

5.3.3 Measuring Electrode Removal

1. Remove electrode holder cap and slide up the measuring electrode cable.
2. Disconnect screw cap cable connection.
3. Loosen the electrode holder.
4. Remove measuring electrode.

5.3.4 Measuring Electrode Installation

1. Wet the measuring electrode with DI water.
2. Replace o-ring up to the shoulder.
3. Place measuring electrode into electrode holder in flow chamber cover marked “M”.
4. Hand-tighten electrode holder.
5. Re-connect and tighten screw cap cable connection.
6. Replace electrode holder cap and finger tighten.

5.4 Replacement Parts List

Part Number	Description
31117390	Glass Measuring Electrode (w/o cable)
51198296-001	Glass Flowing Reference Electrode (w/o cable)
51198259-001	Temperature Sensor/Solution Ground - 36 ft Integral Cable
51198259-002	Temperature Sensor/Solution Ground - 20 ft Integral Cable
51198266-001	Cover Gasket
30669860-011	Electrode O-Rings (2 needed per electrode)

Part Number	Description
30669860-012	Temperature Sensor/Counter Electrode O-Ring
51204751-001	Temperature Sensor/Counter Electrode Bushing
30669860-013	Inlet/Outlet Fitting O-Ring
51204762-001	Calibration Cup
51204774-001	Reference Solution Reservoir
	Reference Electrode Tubing - 1/8 I.D. x 1/4 O.D. Silicone Tubing (Cole Parmer #06411-67 recommended)
51204773-001	Reservoir Fitting
51204752-001	Reference Solution
31103001	4.01 Buffer Solution
31103002	6.86 Buffer Solution
31103003	9.18 Buffer Solution
51204765-001	Measuring Electrode Cable - 36 ft
51204765-002	Measuring Electrode Cable - 20 ft
51204768-001	Reference Electrode Cable - 36 ft
51204768-002	Reference Electrode Cable - 20 ft

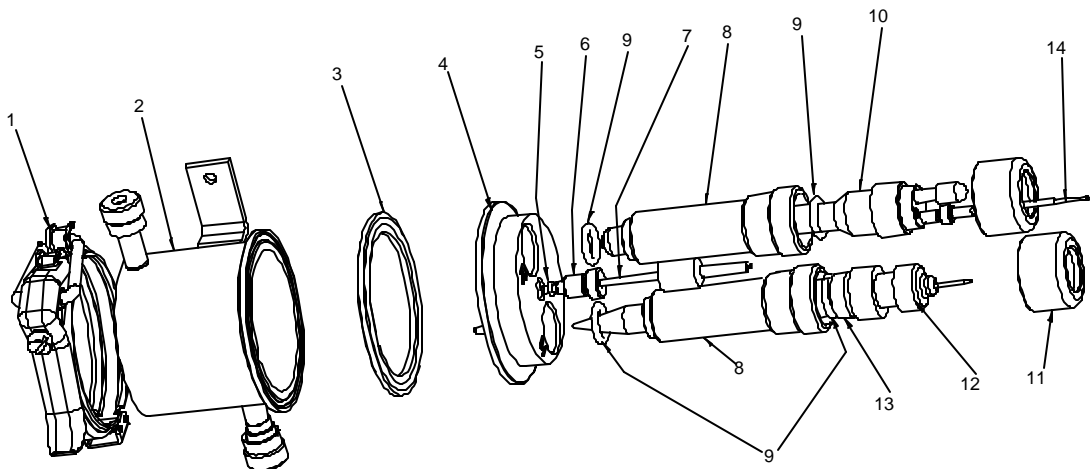

Figure 5-1 Sensor Assembly

Callout Number	Description
1	Clamp, Sanitary
2	High Purity Water Flow Chamber
3	Gasket

Callout Number	Description
4	Cover Machined
5	"O" Ring
6	Compression Nut
7	Thermistor Probe Assembly (20 foot)
7	Thermistor Probe Assembly (36 foot)
8	Universal Adapter
9	"O" Ring
10	Reference Electrode Assembly
11	Locking Cap
12	Cable Assembly Measuring Electrode (20 foot)
12	Cable Assembly Measuring Electrode (36 foot)
13	Measuring Electrode Assembly
14	Cable Assembly Reference Electrode (20 foot)
14	Cable Assembly Reference Electrode (36 foot)

Honeywell

Industrial Automation and Control

Honeywell, Inc.

1100 Virginia Drive

Fort Washington, Pennsylvania 19034