

## **DirectLine<sup>®</sup> DL424/425 Sensor Module *for* DL 5000 Dissolved Oxygen Probes User Manual**

70-82-25-113

Rev. 3

3/03

---

## Notices and Trademarks

Copyright 2003 by Honeywell  
March 2003

### Warranty/Remedy

Honeywell warrants goods of its manufacture as being free of defective materials and faulty workmanship. Contact your local sales office for warranty information. If warranted goods are returned to Honeywell during the period of coverage, Honeywell will repair or replace without charge those items it finds defective. The foregoing is Buyer's sole remedy and is **in lieu of all other warranties, expressed or implied, including those of merchantability and fitness for a particular purpose**. Specifications may change without notice. The information we supply is believed to be accurate and reliable as of this printing. However, we assume no responsibility for its use.

While we provide application assistance personally, through our literature and the Honeywell web site, it is up to the customer to determine the suitability of the product in the application.

### CE Conformity

This product is in conformance with the protection requirements of the following European Council Directives: 89/336/EEC, the Electromagnetic Compatibility Directive and 73/23/EEC, the Low Voltage Directive. Conformance of this product with any other "CE Mark" Directive(s) shall not be assumed.

### ATTENTION

The emission limits of EN 61326 are designed to provide reasonable protection against harmful interference when this equipment is operated in an industrial environment. Operation of this equipment in a residential area may cause harmful interference. This equipment generates, uses and can radiate radio frequency energy and may cause interference to radio and television reception when the equipment is used closer than 30 m to the antenna(e). In special cases, when highly susceptible apparatus is used in close proximity, the user may have to employ additional mitigating measures to further reduce the electromagnetic emissions of this equipment.

### Industrial Measurement and Control

Honeywell  
1100 Virginia Drive  
Fort Washington, PA 19034

DirectLine is a trademark of Honeywell

Other brands or product names are trademarks of their respective owners

*Insert 70-82-10-04 should accompany this document.*

---

# About This Document

## Abstract

This manual contains all the information that is needed to install, configure, calibrate, operate, and troubleshoot the DirectLine<sup>®</sup> Sensor. Insert 70-82-10-04, a quick reference guide for configuring and calibrating the DL424/425, should accompany this document.

## Contacts

### World Wide Web

The following lists Honeywell's World Wide Web sites that will be of interest to our customers.

Honeywell Organization	WWW Address (URL)
Corporate	<a href="http://www.honeywell.com">http://www.honeywell.com</a>
Industrial Measurement and Control	<a href="http://www.honeywell.com/imc">http://www.honeywell.com/imc</a>

### Telephone

Contact us by telephone at the numbers listed below.

	Organization	Phone Number
United States and Canada	Honeywell	1-800-423-9883 <i>Tech. Support</i>
		1-888-423-9883 <i>Q&amp;A Faxback (TACFACS)</i>
		1-800-525-7439 <i>Service</i>

## Symbol Definitions

The following table lists any symbols used in this document to denote certain conditions.

Symbol	Definition
	Earth Ground. Functional earth connection. NOTE: This connection shall be bonded to Protective earth at the source of supply in accordance with national and local electrical code requirements.

---

# Contents

<b>1. INTRODUCTION .....</b>	<b>1</b>
1.1 Overview .....	1
1.2 Electronics Module .....	2
1.3 Operator Interface.....	2
1.4 Specifications.....	3
1.5 Model Selection Guide .....	4
<b>2. INSTALLATION .....</b>	<b>5</b>
2.1 Assembly and Wiring.....	5
2.2 Integral Mounting .....	7
2.3 Remote Mounting .....	8
2.4 Conduit connections .....	12
<b>3. CONFIGURATION .....</b>	<b>13</b>
3.1 Overview.....	13
3.2 Configuration Set Up Procedure.....	15
<b>4. CALIBRATION.....</b>	<b>19</b>
4.1 New Probe .....	19
4.2 Calibration Options .....	19
4.3 Calibration Procedures .....	20
<b>5. OPERATION .....</b>	<b>22</b>
5.1 Displays .....	22
5.2 Diagnostic Error Messages .....	24
5.3 Unit Reset.....	26
<b>6. SPARE PARTS .....</b>	<b>27</b>
<b>7. APPENDIX: CE MARK APPLICATIONS .....</b>	<b>29</b>
<b>8. SALES AND SERVICE .....</b>	<b>31</b>

---

## Tables

Table 2-1 Assembly and Wiring Procedure for Field Wiring Connector	6
Table 2-2 Integral Mounting Procedure (refer to Figure 2-3)	7
Table 2-3 Remote Mounting Procedure for DL5000 Probes	8
Table 3-1 Dependence of Barometric Pressure on Altitude	13
Table 3-2 Configuration Set Up Procedure	15
Table 4-1 Calibration Procedure	20
Table 5-1 Online Parameter Descriptions	22
Table 5-2 Display Navigation Procedure	23
Table 5-3 Online Diagnostic Errors	24
Table 5-4 Factory Default Values	26

---

## Figures

Figure 1-1	DirectLine® Sensor	1
Figure 1-2	Electronics Module	2
Figure 2-1	Cordset Connection and Wiring	5
Figure 2-2	Field Wiring Connector	6
Figure 2-3	Integral Mounting	7
Figure 2-4	Remote Mounting	10
Figure 2-5	Remote Mounting Hardware	11







# 1. Introduction

## 1.1 Overview

The DirectLine® Sensor for dissolved oxygen measurement in water consists of a **DL424/425 electronics module** connected to a **DL5000 DO Probe**. The modular electronics design allows the module to be separated from the probe, so that the probe can be easily removed or replaced while retaining power to the electronics module.

The DL424/425 **electronics module** is contained in a Nema Type 4x sealed weatherproof corrosion/impact-resistant polysulfone housing. The Module can be mounted as an integral unit directly connected to the probe or remotely using a probe with a cable. The sealed plastic housing has plug-in connections for the DL5000 probe and a 4-20 mA output connection.

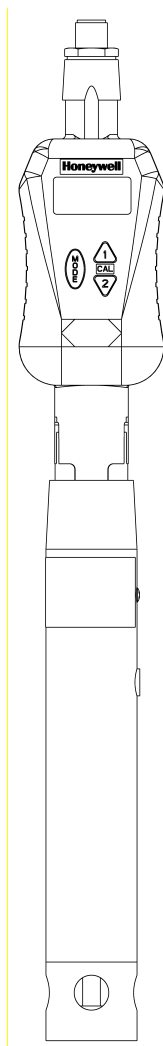

Figure 1-1 DirectLine® Sensor

## 1.2 Electronics Module

The electronics module is loop-powered by 16-42 Vdc and will modulate its supply current from 4 mA to 20 mA, depending upon the DO value that is measured by the probe. The transmitted loop current is compensated for process temperature.

A 4-20 mA output connection is provided via a 6m cordset or a customer supplied cable used in combination with a field wiring connector.

The DirectLine® electronic module for dissolved oxygen measurements is available in two configurations:

- ppm (DL424) and ppb (DL425).

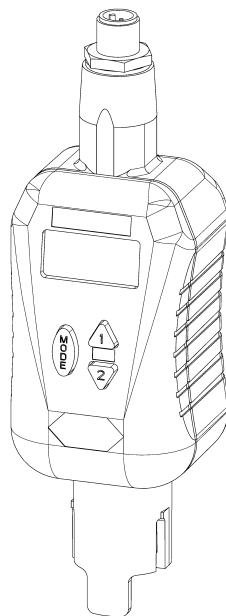

**Figure 1-2 Electronics Module**

## 1.3 Operator Interface

The DirectLine® Sensor operator interface consists of three pushbuttons and one 4-digit, 7-segment LCD display with 3 decimal points, plus (+), and minus (–) signs. It is responsible for the display of measured values and configuration of parameter values.

## 1.4 Specifications

### General:

<b>Displayed Process Variable</b>	DL424: 0-20 ppm dissolved oxygen DL425: 0-200 ppb dissolved oxygen
<b>Displayed Temperature Range</b>	2.0 to 60.0 °C (35.6 to 140°F)
<b>Operating Temperature</b>	-20 °C to +60 °C (-4 °F to +140 °F)
<b>Storage Temperature</b>	-20 °C to +70 °C (-4 °F to +158 °F)
<b>Display Resolution</b>	DL424: 0.01 ppm DL425: 0.1 ppb in the 0-20 ppb range; 1 ppb in the 0-200 ppb range
<b>Output Type</b>	4-20 mA (2-wire loop powered)
<b>Output Scale</b>	DL424: 0-20ppm DL425: 0-200ppb
<b>Output Calibration</b>	4-20 mA
<b>Power</b>	16-42 Vdc <i>Maximum Load Resistance:</i> 250 ohms at 16 Vdc 600 ohms at 24 Vdc 1400 ohms at 42 Vdc
<b>Calibration Options</b>	Air Cal; Sample Cal
<b>Diagnostics</b>	Sensor and electronics

### Physical Properties:

<b>Case</b>	Weatherproof, corrosion-resistant plastic housing
<b>Local Display and Buttons</b>	LCD 4-digit, 7-segment
<b>Field Wiring Cordset</b>	Shielded twisted pair. Length: 6 m (19.7')
<b>User Termination</b>	Tinned leads
<b>Remote Mounting</b>	Pipe, Wall, or DIN Rail
<b>Dimensions</b>	H 123 mm (4.84") x W 48 mm (1.89") x D 46 mm (1.81")
<b>Weight</b>	Approximately 142 g (5.0 oz.)
<b>Approvals</b>	CE Mark - Industrial Applications UL – General Purpose CSA – General Purpose IP66 Enclosure NEMA Type 4 FM Class1, Div. 1 (I.S.) FM Class 1, Div. 2 (non-incendive field wiring)

## 1.5 Model Selection Guide

### Instructions

- Select the desired key number. The arrow to the right marks the selection available.
- Make the desired selections from Tables I through IV using the column below the proper arrow. A dot (•) denotes availability.

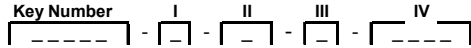

### Key Number - DirectLine® Sensor Electronics Module

(Specify electrodes/cells/probes separately)

		Selection	Availability				
pH	For use with Durafet II, Meredian II & HPW7000 pH electrodes	DL421	↓				
ORP	For use with ORP electrode.	DL422		↓			
Conductivity	For use with Contacting Conductivity Cells	DL423			↓		
DO - PPM	For use with Dissolved Oxygen ppm Probes	DL424				↓	
DO - PPB	For use with Dissolved Oxygen ppb Probes	DL425					↓

### TABLE I - OUTPUT CABLE

Output Cable for Integral or Remote Mounting		D	E	F
None (replacement module or customer supplied output cable)- <b>Note 1</b>		•	•	•
Cordset - 6m (19.7 ft.) - includes connector and cable - <b>Note 2</b>		•	•	•
Field Wiring Connector <b>only</b> - customer supplies cable only- <b>Note 2</b>		•	•	•

### TABLE II - SENSOR CABLE/REMOTE CONNECTOR (between electronic module and electrode, sensor or probe)

Integral Mounting		0	1	2	3	4	5	6
None	No cable or connector required	d	d	d	d	d		
Remote Mounting Cable - Durafet only	6,096m (20 ft.) of sensor cable - Durafet II Remote Mounting	e						
	15,24m (50 ft.) of sensor cable - Durafet II Remote Mounting	e						
Remote Mounting Connector (Cable is supplied with sensor or probe)	Remote Mounting Connector - Meredian II pH	e						
	Remote Mounting Connector - Meredian II ORP		e					
	Remote Mounting Connector - HPW7000	e						
	Remote Mounting Connector - Conductivity				e			
	Remote Mounting Connector - Dissolved Oxygen						e	e

### TABLE III - REMOTE MOUNTING OPTIONS

Mounting Kit for Remote Mounting		A	B
None	Integral unit - mounting not required	•	•
	2" (5,08 cm) Pipe mtg. bracket, wall mtg. & DIN Rail clip	•	•

### TABLE IV - OPTIONS

Tagging		00__	LT__	SS__
None		•	•	•
Linen Customer ID Tag - 3 lines w/22 characters/line		•	•	•
SS Customer ID Tag - 3 lines w/22 character/line		•	•	•
Certificates	None	__00	•	•
	Calibration & Conformance	__CC	•	•

#### Notes:

- Customer supplies cordset **or** cable with M12 connector. Suppliers & P/Ns include:

	Phoenix Contact	Turck
Cord--set	SAC-3P-5.0-PUR/M12FSSH Stainless	RKV4T-6/S618
M12 Field Wiring Connector	SACC-M12FS-4CON-PG7	B8141-0
Cable	2-wire twisted shielded pair	

- Recommended cable is 2-wire twisted shielded pair

#### RESTRICTIONS

Restriction Letters	Available Only With		Not Available With	
	Table	Selection	Table	Selection
d	III	A		
e	III	B		

#### ORDERING INSTRUCTIONS:

- Part numbers are provided to facilitate Distributor Stock.
- Orders may be placed either by model selection or by part number.
- Part numbers are shown within the model selection tables to assist with compatibility information.
- Orders placed by model selection are systematically protected against incompatibility.
- Compatibility assessment is the responsibility of the purchaser for orders placed by part number.
- Items labeled as N/A are not available via the stocking program and must be ordered by model selection.

## 2. Installation

### 2.1 Assembly and Wiring

Depending on the customer selected output cable options, the DirectLine can be wired to an appropriate 16-42 Vdc source using 2 different methods:

- 1) Cordset. See Figure 2-1.
  - 2) Field wiring connector with customer supplied cable. See page 6.
- Refer to Section 7 for wiring for CE Mark applications.

#### 2.1.1 Cordset

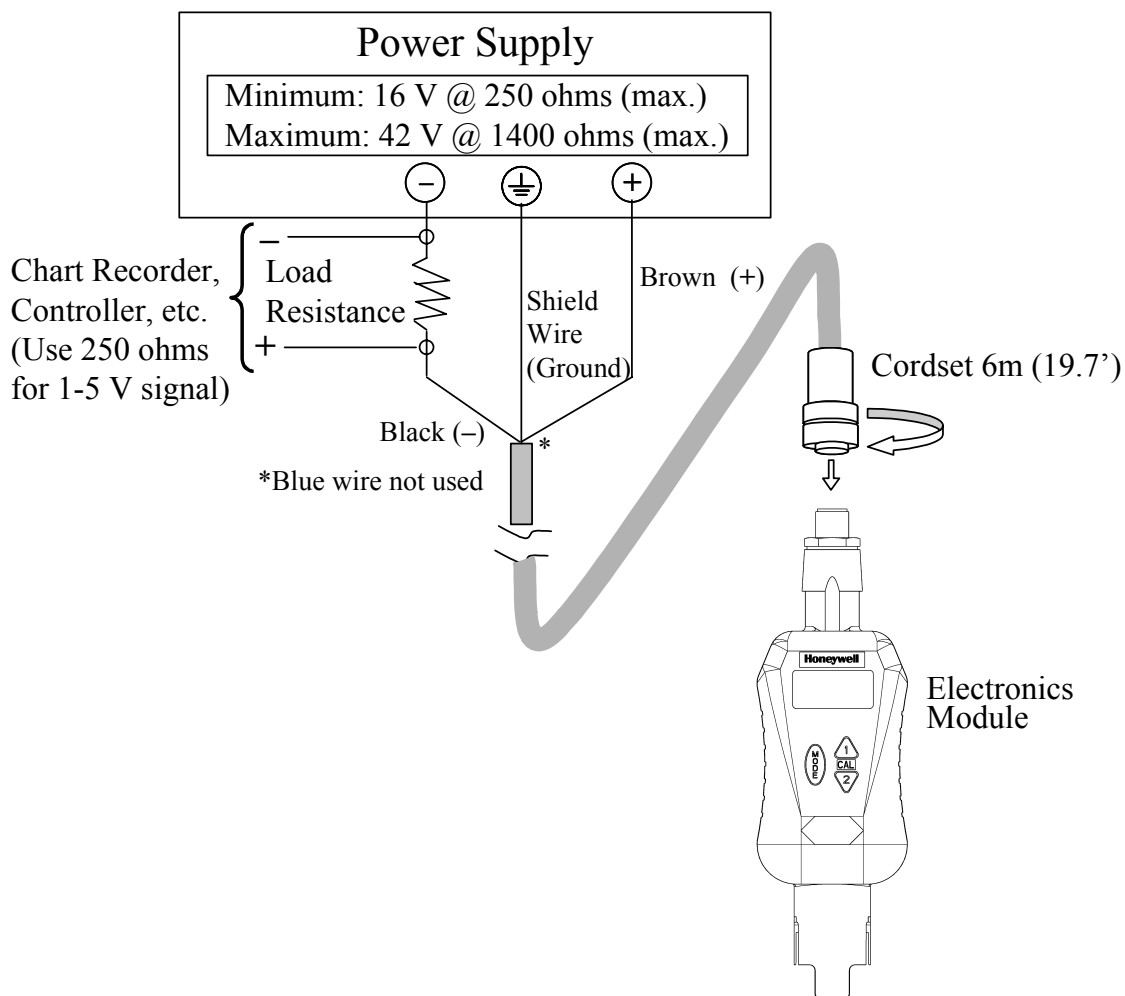

**Figure 2-1 Cordset Connection and Wiring**

### 2.1.2 Field Wiring Connector with customer supplied cable

Refer to Figure 2-2. The field wiring connector supports customer supplied cable with an outer diameter of 4-6mm, 2-wire twisted shielded pair. Required cable is 2-wire twisted shielded pair with UV resistant outdoor rated outer jacket material. Use of a non-UV resistant, non-outdoor rated cable will void the NEMA 4 outdoor rating.

**Table 2-1 Assembly and Wiring Procedure for Field Wiring Connector**

Step	Procedure
<b>1</b>	<b>Disassemble field wiring connector</b> a) Unscrew parts to separate pressure screw, clamp type cage, gasket, housing and female insert.
<b>2</b>	<b>Insert customer supplied cable through connector parts</b> a) Slide pressure screw over skin and tinned customer cable (note orientation). b) Slide clamp type cage over cable (note orientation). c) Slide gasket over cable. d) Slide housing over cable (note orientation).
<b>3</b>	<b>Connect wires to pins</b> Look closely at end of female insert to locate pin numbers. Connect positive wire to pin 1 and negative wire to pin 4. Remaining wires and female insert pins 2 and 3 are unused.
<b>4</b>	<b>Assemble field wiring connector</b> a) Screw female insert to housing until female insert's o-ring is compressed. b) Slide clamp type cage/gasket into housing. c) Thread pressure screw into housing until ¼ turn past finger tight.
<b>5</b>	<b>Connect cable to power supply</b> Wire the other end of the Output cable to a 16-42 Vdc source as indicated in Figure 2-1. Note: your wire colors may be different.

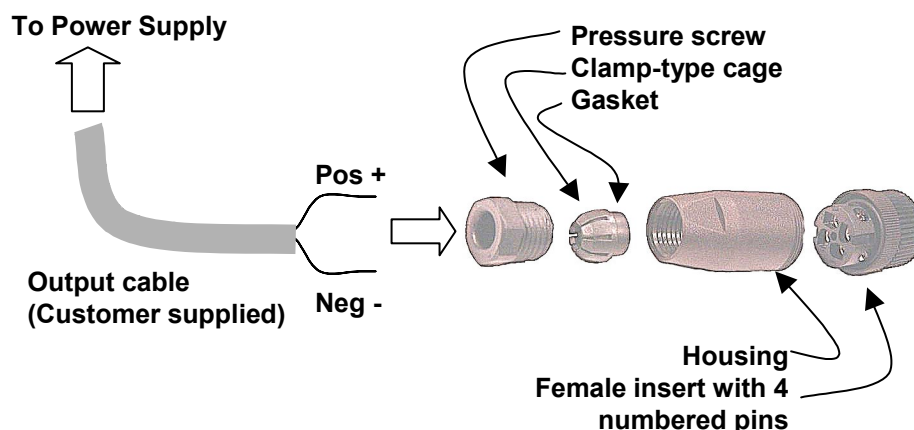
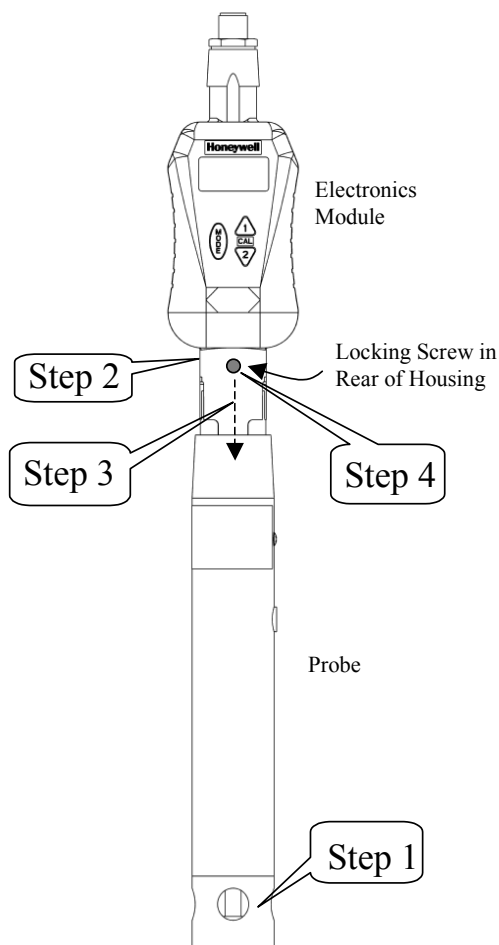

**Figure 2-2 Field Wiring Connector**

## 2.2 Integral Mounting

**Table 2-2 Integral Mounting Procedure (refer to Figure 2-3)**

Step	Procedure
1	Connect the probe to the process source (using the appropriate mounting from those supplied for the DL5000). Make sure that the final position of the installed electronics module allows the display to be easily viewed by personnel.
2	Apply a thin film of silicon grease on the ID of the electronics module's probe mounting cavity.
3	Align the slots on the electronics module with those on the probe and press down to connect the electronics to the probe.
4	Tighten the locking screw on the bottom rear of the electronics module. Do not exceed 5 in-lb.



**Figure 2-3 Integral Mounting**

### 2.3 Remote Mounting

When the DL424 or DL425 module is specified with Table II = 6, a remote connector assembly (part number 51500768-005) is supplied loose. The remote cable connector is used to connect the DL5000 probe cable to the DL424/425 module. Table 2-3 gives the mounting procedure.

**Table 2-3 Remote Mounting Procedure for DL5000 Probes**

Step	Procedure (Refer to Figure 2-4 and Figure 2-5)
1	Remove the protective sleeve from the end of the probe cable when ready to attach to remote connector. Be careful to keep bare fingers away from coax cable termination.
2	Turning counterclockwise, remove strain relief/cover combination from the remote connector assembly.
3	Loosen and remove compression cap from strain relief fitting. Carefully push cable end through cap and strain relief fitting so that these parts are strung back along cable jacket.
4	Connect cable leads <i>in reverse numerical order</i> as follows: Terminal 6 = Cathode Silver Pin(coax) Terminal 5 = Reference (Green) Terminal 4 = Anode (Red) Terminal 3 = Temperature Compensation Lead (Yellow) Terminal 2 = Temperature Compensation Lead (Orange) Terminal 1 = Pigtail Shield Lead (Black/White) Earth Ground = Blue
5	Apply a thin bead of silicone grease to cable jacket in the area of the compression cap/strain relief. Slide cover along cable and tighten by hand onto the remote connector assembly.
6	Slide cap along cable and tighten onto cable jacket with small wrench until cable cannot slide within strain relief rubber bushing.
7	Apply a thin film of silicon grease to the ID of electronics module's remote mounting cavity.
8	Plug remote connector assembly into DL424/425 module aligning polarity tab of module housing and mating groove on connector. ( <i>continued</i> )



Step	Procedure (Refer to Figure 2-4 and Figure 2-5)
9	<p data-bbox="394 254 1365 289"><b>Secure Electronics Module with Wall, Pipe, or DIN Rail Mounting</b></p> <ul data-bbox="443 300 1377 369" style="list-style-type: none"><li data-bbox="443 300 1377 369">• Mount bracket with clips facing forward, smaller clip on top and larger clip on bottom.</li></ul> <p data-bbox="428 380 1243 415"><i>Wall:</i> Use one of three through-holes to secure to wall.</p> <p data-bbox="428 422 1328 457"><i>Pipe:</i> Feed hose clamp through two slots and secure to pipe.</p> <p data-bbox="428 464 1393 499"><i>DIN rail:</i> Attach the appropriate DIN rail clip to the mounting bracket:</p> <ul data-bbox="586 506 1409 615" style="list-style-type: none"><li data-bbox="586 506 1409 541">“U” DIN rail—use metal clip and shorter screw (8 mm)</li><li data-bbox="586 548 1409 615">“G” DIN rail—use gray clip and longer screw (10 mm). Clip can be rotated for horizontal or vertical DIN rails.</li></ul> <ul data-bbox="443 625 1419 695" style="list-style-type: none"><li data-bbox="443 625 1419 695">• Push electronics module onto the remote-mounting bracket until it snaps into position.</li></ul>

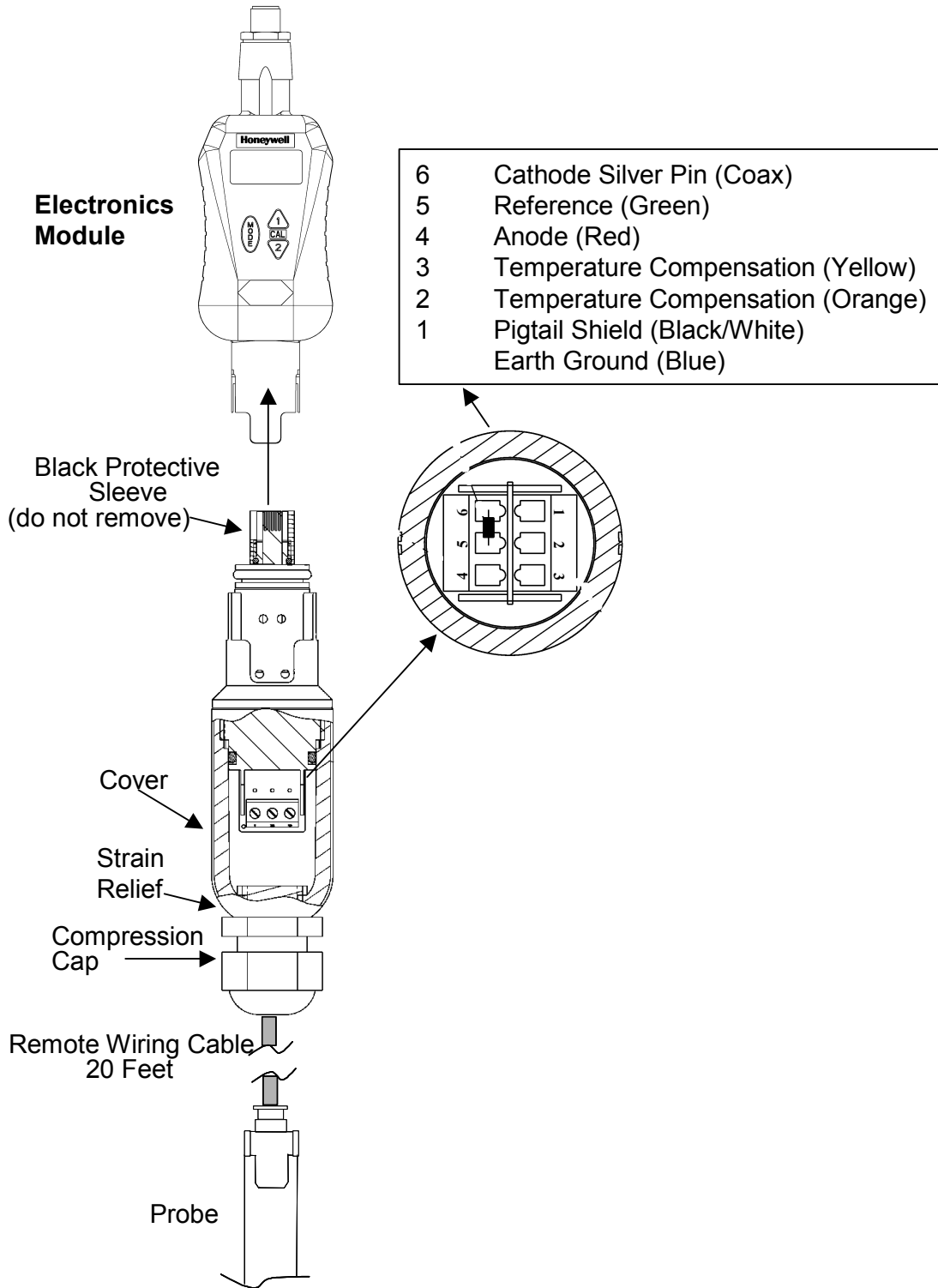

**Remote Electronics for  
Module DL5000 Dissolved Oxygen Probes**

**Figure 2-4 Remote Mounting**

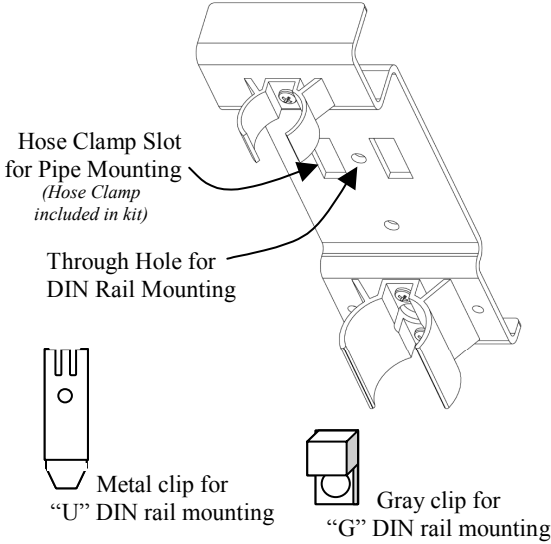

**Mounting Kit**

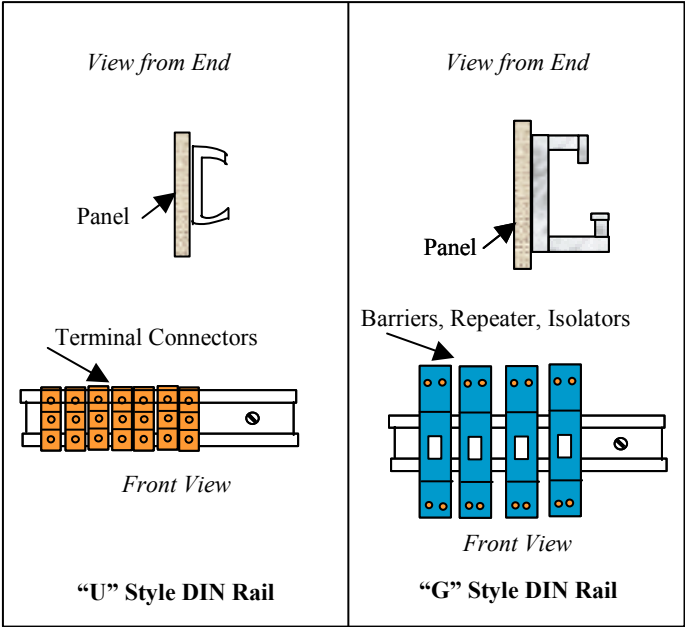

**Figure 2-5 Remote Mounting Hardware**

## 2.4 Conduit connections

The DirectLine provides a male ½" NPT thread to accommodate a customer conduit connection. Use ½" conduit coupling (min. 38.1mm (1.5") long) on DL conduit connection to clear cordset connector. Conduit can not be used with field wiring connector due to size restriction.

Do not exceed 200in-lb. torque when attaching fixed piping.

Use wrench flats provided under the ½" NPT threads to support the DirectLine during installation.

## 3. Configuration

### 3.1 Overview

#### Configuration Parameters

Set Up consists of configuring the following functions:

- **Atmospheric Pressure Compensation:**

The solubility of oxygen in water and DL5000 dissolved oxygen probe signal directly respond to barometric pressure and hence pressure compensation is not required during use. For best accuracy, the DL424/425 modules need to know barometric pressure at the time of probe calibration. If barometric pressure is known, this value can be readily entered into the instrument at this time. This value will be automatically accessed during air calibration.

A major contributor to atmospheric pressure is altitude above or below sea level. In the absence of a specific knowledge of barometric pressure value, use the nominal barometric pressure value from **Table 3-1**.

The factory default barometric pressure value is 760 millimeters of mercury (mmHg). Any value can be entered in one step increments from 500 to 800 mm Hg.

- **Salinity:** The solubility of oxygen in salt or brackish waters, containing much more than 1 part per thousand (ppt) total dissolved solids, is dependent on salt concentration. The DL424 instrument accepts the total dissolved salt concentration in ppt and performs necessary calculations to obtain the correct dissolved oxygen concentration over salt concentration and sample temperature. The DL 424 factory default value is 0 ppt but valid readings can range from 0 - 40 ppt and can be entered by the user in 0.1ppt increments. The DL425 is intended for high purity water applications; salinity compensation is not employed here.

**Table 3-1 Dependence of Barometric Pressure on Altitude**

Alt. ft	P. mmHg	Alt. ft	P. mmHg
Sea Level	760	3000	681
200	755	3200	676
400	749	3400	671
600	744	3600	666
800	738	3800	661
1000	733	4000	656
1200	728	4200	652
1400	722	4400	647
1600	717	4600	642
1800	712	4800	637
2000	707	5000	632
2200	701	5200	628
2400	696	5400	623
2600	691	5600	618
2800	686	5800	614

- **Probe Bias Voltage** – This feature is not applicable to typical DO applications and is generally performed as a result of a “berr” message.
- The probe bias voltage value determines the voltage applied to the DO probe's cathode, relative to the reference electrode, to drive the reduction of oxygen to water at the cathode and thereby induce a current which is directly proportional to the oxygen consumed. A proper probe bias voltage allows for the complete reduction of all oxygen at the cathode, without regard for small changes in the voltage characteristics of the probe. This parameter can be read, scanned or reset to the factory default value.
- In the DL425, the automated probe bias voltage option is only allowed when the probe has been removed from the process.
- In the DL424, in applications containing carbon dioxide, it may be undesirable to remove the probe from the process. Therefore in the DL424 the probe bias voltage can be edited directly in the process.
- **Noise Suppression Frequency Selection** – Selection of 50 Hz or 60 Hz. Defaults to 60 Hz at unit reset.
- **Output Configuration and Calibration** – Selection of Output Configuration functions: 0% Calibration, 100% Calibration, 0% Output Range Value, 100% Output Range Value.

Table 3-2 provides steps and entry information for the complete configuration sequence.

### 3.2 Configuration Set Up Procedure

**ATTENTION:**

In Table 3-2, under the **Press** column:

- **Hold** means to hold the button down until the display changes.
- **Momentarily** means to press and release the indicated button.

From the Online DO display, follow this procedure.

**ATTENTION:**









***If no key is pressed for 60 seconds, the display will abort the entry mode and default to Online Display.***

**Table 3-2 Configuration Set Up Procedure**

Step	Operation	Press	Display
1	Enter <b>Atmospheric Pressure Compensation</b>	<b>MODE Hold</b>	<b>AtPr</b> (for 1 second), then <i>Value of Atmospheric Pressure Value in mm Hg</i>
	Edit Atmospheric Pressure Value	<b>MODE Hold</b>	<b>Flashing Display – You are now in EDIT mode</b> ( <i>Value of Current Atmospheric Pressure Compensation</i> )
	Select a new value	<b>▲ or ▼ Momentarily</b>	Enter a value from 500 to 800 mm Hg (760 mm HG default)
	Save the value	<b>MODE Momentarily</b>	Saves the new Atmospheric Pressure Compensation value for use at the next Air Calibration.
2	Enter <b>Salinity Compensation (ppm units only)</b>	<b>MODE Momentarily</b>	<b>SALn</b> (for 1 second), then <i>Value of current Salinity Compensation in Parts per Thousand</i>
	Edit Salinity Compensation	<b>MODE Hold</b>	<b>Flashing Display – You are now in EDIT mode</b> ( <i>Value of current Salinity Compensation</i> )
	Select a new value	<b>▲ or ▼ Momentarily</b>	Enter a value from 0 (default) to 40 ppt
	Save the value	<b>MODE Momentarily</b>	Saves the new Salinity Compensation Value

Step	Operation	Press	Display
3	Enter <b>Probe Bias Voltage</b> (not needed for typical applications – do not use unless “berr” is indicated or there is a historical precedence for operating at a different setting)	<b>MODE</b> <b>Momentarily</b>	<b>b IAS</b> (for 1 second), then <i>Value of current Probe Bias Voltage in Volts</i> <i>Go to 3a, 3b, or 3c</i> <b>Remove the probe from the process prior to 3a - Probe Bias Calibration.</b>
	3a. <b>Automated Probe Bias Voltage</b>	<b>▲</b> <b>Hold</b> <b>(3 seconds)</b>	<b>Flashing Display – bIAS</b> Bias Scan begins and the display flashes until the scan is complete. An optimal Probe Bias value is determined and <b>displayed</b> after the scan is complete (up to 2 minutes). Note: Pressing the MODE button momentarily during scanning process aborts the scan and the prior Probe Bias value is retained.
	3b. <b>Reset the Probe Bias Value</b>	<b>▼</b> <b>Hold</b> <b>(10 seconds)</b>	Display will show "0.55". Probe Bias Voltage is reset.
	3c. <b>Manual input for Probe Bias</b>	<b>MODE</b> <b>Hold</b> <b>(3 seconds)</b>	Display will flash the current probe bias value.
	Select a new value	<b>▲ or ▼</b> <b>Momentarily</b>	Use up/down arrows to edit Probe Bias
	Save the Probe Bias Voltage	<b>MODE</b> <b>Momentarily</b>	Saves the Probe Bias Voltage
4	Enter <b>Noise Suppression Frequency</b>	<b>MODE</b> <b>Momentarily</b>	<b>nSUP</b> (for 1 second) then, <i>(Noise Suppression Frequency Selection)</i>
	Edit Noise Suppression Frequency	<b>MODE</b> <b>Hold</b>	<b>Flashing Display – You are now in EDIT mode</b> <i>(Value of current Frequency selection)</i>
	Select desired Frequency	<b>▲▼</b> <b>Momentarily</b>	to select 50 Hz or 60 Hz (default)



Step	Operation	Press	Display
	Save the Noise Suppression Frequency	<b>MODE</b> <b>Momentarily</b>	Saves the selection for frequency
5	Enter <b>Output Configuration</b>	<b>MODE</b> <b>Momentarily</b>	<b>OutC</b> <i>Enter Output Calibration</i>
	100% Range Value Selection	 <b>Momentarily</b>	<b>rnGH</b> (for 1 second) then, (Value of current 100 % Range Value Selection)
	Edit 100% Range Value Selection	<b>MODE</b> <b>Hold</b>	<b>Flashing Display – You are now in EDIT mode</b> (Value of current 100 % selection)
	Select desired 100% DO Range	  <b>Momentarily</b>	Selected 100% DO Value Range: DL424 = 0 to 20 ppm DL425 = 0 to 200 ppb
	Save the New 100% Range Value	<b>MODE</b> <b>Momentarily</b>	(New Value)
6	0 % Range Value Selection	 <b>Momentarily</b>	<b>rnGL</b> (for 1 second) then, (value of current 0% Range Value Selection)
	Edit 0 % Range Value Selection	<b>MODE</b> <b>Hold</b>	<b>Flashing Display – You are now in EDIT mode</b> (value of current 0 % selection)
	Select 0 % DO Value	  <b>Momentarily</b>	Selected 0 % DO Value Range: DL424 = 0 to 20 ppm DL425 = 0 to 200 ppb
	Save the New 0 % Range Value	<b>MODE</b> <b>Momentarily</b>	(New Value)
7	100 % Calibration	 <b>Momentarily</b>	<b>AdJH</b>
	Adjust 100 % Calibration	<b>MODE</b> <b>Hold</b>	<b>AdJH (flashes) – You are now in EDIT mode</b> Range: 19.60 to 20.40 mA typically (default 20.00 mA)
		  <b>Momentarily</b>	<b>+AdJH</b> (increments value) <b>-AdJH</b> (decrements value)

Step	Operation	Press	Display
	Save 100 % Calibration	<b>MODE</b> <b>Momentarily</b>	<b>AdJH</b>
<b>8</b>	0 % Calibration	<b>▼</b> <b>Momentarily</b>	<b>AdJL</b>
	Adjust 0 % Calibration	<b>MODE</b> <b>Hold</b>	<b>AdJL (flashes) – You are now in EDIT mode</b> Range: 3.80 to 4.40 mA typically ( <i>default 4.00 mA</i> )
		<b>▲</b> <b>▼</b> <b>Momentarily</b>	<b>+AdJL</b> (increments value) <b>-AdJL</b> (decrements value)
	Save 0 % Calibration	<b>MODE</b> <b>Momentarily</b>	<b>AdJL</b>
<b>9</b>	Return to Online Display	<b>MODE</b> <b>Momentarily</b>	<b>Returns to Output Configuration</b>
		<b>MODE</b> <b>Momentarily</b>	<b>Returns to Online Display</b>

---

## 4. Calibration

### 4.1 New Probe

#### New Probe Reset Option

Upon system power up or probe connection, the new probe reset option is displayed. The **nPrb** message is available for 2 minutes and can be selected by pressing the up arrow until the display changes to the unit type and DO value. The user must select this option when inserting a new probe. The Air and Sample calibration values are set to the factory defaults and the probe current is measured and saved as a diagnostic aid. An Air calibration is recommended after a new probe is installed.

If a new probe is not installed, the operator can return to on-line measurement by waiting for the 2 minute timeout or by pressing the Mode button.

### 4.2 Calibration Options

#### Introduction

Whether the probe is connected for the first time, replaced or just disconnected and then reconnected, a reconditioning period is needed before the probe can make an accurate measurement. (See DL5000 Probe Manual 70-82-25-114)

#### Options

Two Calibration options are available: Air and Sample Calibration.

These parameters can only be selected when online DO is displayed.

- **Air Calibration** - is done with the probe removed from the process. This is the recommended method of calibration and should be completed unless the process set-up prohibits removing the probe. This is recommended prior to installation as it saves system parameters that are used in optimizing error diagnostics.

If the probe has just been removed from a sample low in dissolved oxygen, it takes longer to complete a calibration than that of a probe that is already near ambient conditions (sample high in dissolved oxygen).

- **Sample Calibration** - Sample calibration allows a calibration based on a known dissolved oxygen concentration where a DO value may be entered that is based on a reference measurement. Sample calibration is usually executed by leaving the probe in the measured sample and adjusting the DirectLine® to agree with the sample dissolved oxygen measured with a properly calibrated portable dissolved oxygen meter whose probe is held very close to the process probe.

For those situations where sample calibration is preferred, it is recommended that an Air Calibration be performed before the probe is put into service. It is also good practice to Air Calibrate the probe once every 2 - 4 months of service.

### 4.3 Calibration Procedures

**ATTENTION:**

In Table 4-1, under the **Press** column:

- **Hold** means to hold the button down until the display changes.
- **Momentarily** means to press and release the indicated button.

**Table 4-1 Calibration Procedure**

Step	Operation	Press	Display
1	Air Calibration	<p>▲ ACal Hold (3 seconds)</p> <p>▲ ACal Momentarily</p>	<p><b>ACAL</b> <i>To cancel, press Mode button.</i></p> <p>Air Calibration will be initiated.</p> <ul style="list-style-type: none"> <li>• The output is held at its current Percent-of-range value</li> <li>• The display <b>flashes ACAL</b> while on-line DO and Temperature measurements are monitored for stability.</li> </ul> <p><b>After 20 seconds of stability</b>, the Sample Calibration Trim value is reset to 1.0 and a new Air Calibration is calculated and the display returns to On-line DO.</p> <p>Air Calibration will <b>fail</b> if stability is <b>NOT</b> achieved after 30 seconds</p> <p><b>"FAIL"</b> will display to indicate Air Calibration failure. The previous Air Cal Factor and Sample Trim values will be retained.</p> <p>Press the MODE button to return to On-line display.</p>

Step	Operation	Press	Display
2	Sample Calibration	▼ SCal Hold (3 seconds)	SCAL (1 second), then "Live DO Value" <i>To cancel, press Mode button</i>
		▼ SCal Momentarily	The display changes to a live DO reading, so you can continue to monitor the sample.
		▲ or ▼	To edit the Displayed DO value.  The displayed DO value flashes at the current value and increments or decrements.  The output is held at its current percent of range value.  Press and hold ▲ or ▼ to increment or decrement quickly.
		MODE Momentarily	A new Sample Cal Trim value is calculated.  If successful, the display will change to online DO and the Output hold will terminate.  If an error occurs, "FAIL" will display and return to online DO. The previous Cal Trim value will be retained. Refer to "Diagnostics" for error messages and "What to do".

## 5. Operation

### 5.1 Displays

#### Overview

The DirectLine® DL424/425 displays the On-line DO Concentration value and the On-line Temperature. The table below describes these parameters.

**Table 5-1 Online Parameter Descriptions**

Parameter	Description
<b>Online DO</b>	D424 Range:ppm = 0.00 to 20.00 D425 Range:ppb = 0 to 200
<b>Online Temperature</b>	Measured temperature expressed with fixed tenths decimal precision. Temperature displayed in °C or °F Range: 2.0 to 60.0 °C 35.6 to 140.0 °F

The default display and home position is the **Online DO** display. It appears when:

- The unit is powered up after the nPrb option is selected
- No button presses for 60 seconds
- The Mode button has been pressed during Air or Sample calibration
- The Mode button has been pressed momentarily during a configuration edit

The DO measurement and display is updated at a rate of 500 ms.

In the DL425, when the DO value is outside the 200ppb range, the live DO value will alternately flash ppm and the current reading. The output will be in burnout as the reading is outside the operating range.

**ATTENTION:**

In Table 5-2, under the **Press** column:

- **Momentarily** means to press and release the indicated button.

**Table 5-2 Display Navigation Procedure**

Step	Operation	Press	Display
1	View <b>Online DO Concentration</b> value	<b>MODE</b> <b>Momentarily</b>	<i>(measured DO)</i>
2	View <b>Online Temperature</b>	<b>MODE</b> <b>Momentarily</b>	<i>(measured temperature in °C or °F)</i> Proceed to <b>step 2A</b> or <b>step 3</b> .
2A	Toggle <b>Online Temperature</b> display units	<b>▲</b> or <b>▼</b> <b>Momentarily</b>	<i>(measured temperature in °C or °F)</i> Proceed to <b>step 3</b> .
3	Return to home position	<b>MODE</b> <b>Momentarily</b>	<i>(measured DO)</i>

## 5.2 Diagnostic Error Messages

When a diagnostic error or status condition occurs, the Online Display alternates between measured DO and a text message.

**Table 5-3 Online Diagnostic Errors**

What you see	Cause of Error	What to do
<b>CnFG</b>	Configuration or Calibration data is defective.	Reset unit or cycle power. Second occurrence will show <b>FALt</b> .
<b>FALt</b>	Unit electronics are defective.	Replace electronics module.
<b><i>These errors may occur when on-line DO Concentration or on-line Temperature is displayed.</i></b>		
<b>dOHI</b>	Measured DO is > 20 ppm/200 ppb	Bring process within limits
<b>PrbE</b>	Probe is defective, wrong type, or not connected. Probe current is excessive with probe voltage near 0 volts Forces the output to burnout level (greater than 22 mA).	Check for an electrical short between the anode and the cathode. Check the reference electrode connection. When the source of the error is removed, the error will clear and the output will return to normal operation.
<b>T HI</b>	Measured temperature is > 60 °C	Bring process within limits
<b>T LO</b>	Measured temperature is < 2.0 °C	Bring process within limits
<b>BErr</b>	<ul style="list-style-type: none"> <li>Probe Bias Error: Probe current has exceeded expected probe current in air by 33% and the bias voltage is automatically reduced. If the excessive current condition continues then the <b>PrbE</b> error is generated. If excessive current is not present then the <b>bErr remains</b></li> <li>Application related shift in probe bias voltage.</li> </ul>	<p>For a new probe only – Select nprb and perform an air calibration.</p> <p>For a probe in-use - Remove the probe from process and do a probe bias calibration. In ppm applications in processes containing CO<sub>2</sub>, the probe may be left in the process and the probe bias can be manually adjusted.</p> <p>Remove the probe from the process and do an Air Calibration.</p>



What you see	Cause of Error	What to do
<b>FAIL</b>	This error can occur if <ul style="list-style-type: none"><li>• During air calibration the probe current is too low or if the probe readings are unstable</li><li>• There is excessive probe current during a Probe bias voltage calibration</li></ul> An air calibration can not be completed and the previous air calibration value is retained.	Verify that Probe has been removed from the process.  Verify that probe has reached equilibrium with the process  Press Mode to return to online display.

## 5.3 Unit Reset

### Overview

Unit Reset initializes all of the DirectLine® Sensor’s calibration and configuration data to factory default values. The Air calibration value is also reset to the factory default.

### Procedure

- From the Online DO display, press and hold the ▲ and ▼ buttons simultaneously until “**rSEt**” appears on the display (**minimum of 10 seconds**).
- “**rSEt**” will remain on the display for about 8 seconds followed by the firmware version, the DO Measurement units (ppm or ppb) and the online DO Concentration value. The unit then returns to the Online DO display.

**Table 5-4 Factory Default Values**

<b>Data</b>	<b>Default Values</b>
Air/Sample calibration	<b>Factory default</b>
Atmospheric Pressure	<b>760 mm Hg</b>
Salinity	<b>0 ppt</b>
Probe Bias Voltage	<b>0.55 Volts</b>
Noise Suppression Frequency Selection	<b>60 Hz</b>
Output Configuration – 0 % Range Value	<b>4.00mA</b>
Output Configuration – 100 % Range Value	<b>20.00mA</b>
Output Configuration – 0 % Calibration	<b>0.00 ppm / 0.0 ppb</b>
Output Configuration – 100 % Calibration	<b>20.00 ppm/200 ppb</b>

## 6. Spare Parts

Part Number	Description
51452682-004 51452682-005	DirectLine® DL424 Sensor Module (Replacement Module) DirectLine® DL425 Sensor Module (Replacement Module)
51452683-001	6m Cordset
51452684-001	Field Wiring connector supports customer supplied cable (4-6mm OD)
51452655-001	Remote Mounting Kit for Wall, Pipe, or DIN Mounting
51500768-005	Remote Probe Cable Connector Assembly— Includes O-rings and strain relief
51451371-003	Cable Strain Relief
51198302-006	Internal O-ring for Remote Probe Cable Connector
51452706-001	Locking screw (locks sensor module to probe electrode)

### Cordset

The cordset connection is an M12 female type that can be purchased directly from Honeywell or from multiple vendors including:

#### Turck Industries

Part Number RKV4T-6/S618 for a 6 m cordset with a stainless coupling nut

Part Number RK4T-6/S618 for a 6 m cordset with a nickel plated coupling nut

#### Phoenix Contact

Part Number SAC-3P-5.0-PUR/M12FSSH Stainless for a 5m cordset with a stainless coupling nut

Part Number SAC-3P-5.0-PUR/M12FSSH for a 5m cordset with a nickel plated coupling nut

### Field Wiring connector

The Field Wiring Connector is an all-plastic screw terminal M12 female type that can be purchased directly from Honeywell or from multiple vendors including:

#### Turck Industries

Part Number B8141-0 for a M12 field wiring connector that accommodates customer supplied cable.

#### Phoenix Contact

Part Number SACC-M12FS-4CON-PG7 for a M12 field wiring connector that accommodates customer supplied cable.



## 7. Appendix: CE Mark Applications

**CE Conformity (Europe):** This product is in conformity with the protection requirements of **89/336/EEC**, the EMC Directive. Conformity of this product with any other “CE Mark” Directive(s) shall not be assumed.

Deviation from the installation conditions specified in this manual, and the following special conditions, may invalidate this product’s conformity with the EMC Directive.

**CE Conformity Special Conditions (Europe):** Shielded twisted pair cables are required for I/O interface circuits.



## 8. Sales and Service

For application assistance, current specifications, pricing, or name of the nearest Authorized Distributor, contact one of the offices below.

### ARGENTINA

HONEYWELL S.A.I.C.  
BELGRANO 1156  
BUENOS AIRES  
ARGENTINA  
Tel.: 54 1 383 9290

### ASIA PACIFIC

HONEYWELL ASIA  
PACIFIC Inc.  
Room 3213-3225  
Sun Kung Kai Centre  
N° 30 Harbour Road  
WANCHAI  
HONG KONG  
Tel.: 852 829 82 98

### AUSTRALIA

HONEYWELL LIMITED  
5 Thomas Holt Drive  
North Ryde Sydney  
NSW AUSTRALIA 2113  
Tel.: 61 2 353 7000  
AUSTRIA

### HONEYWELL AUSTRIA

G.m.b.H.  
Handelskai 388  
A1020 VIENNA  
AUSTRIA  
Tel.: 43 1 727 800

### BELGIUM

HONEYWELL S.A.  
3 Avenue de Bourget  
B-1140 BRUSSELS  
BELGIUM  
Tel.: 32 2 728 27 11

### BRAZIL

HONEYWELL DO  
BRAZIL  
AND CIA  
Rua Jose Alves Da  
Chunha  
Lima 172  
BUTANTA  
05360.050 SAO PAULO  
SP  
BRAZIL  
Tel.: 55 11 819 3755

### BULGARIA

HONEYWELL EOOD  
14, Iskarsko Chausse  
POB 79  
BG- 1592 Sofia  
BULGARIA  
Tel.: 359-791512/  
794027/ 792198

### CANADA

HONEYWELL LIMITED  
THE HONEYWELL  
CENTRE  
300 Yorkland Blvd.  
NORTH YORK,  
ONTARIO  
M2J 1S1  
CANADA  
Tel.: 800 461 0013  
Fax:: 416 502 5001

### CZECH

REPUBLIC  
HONEYWELL, Spol.s.r.o.  
Budejovicka 1  
140 21 Prague 4  
Czech Republic  
Tel.: 42 2 6112 3434

### DENMARK

HONEYWELL A/S  
Automatikvej 1  
DK 2860 Soeborg  
DENMARK  
Tel.: 45 39 55 56 58

### FINLAND

HONEYWELL OY  
Ruukintie 8  
FIN-02320 ESPOO 32  
FINLAND  
Tel.: 358 0 3480101

### FRANCE

HONEYWELL S.A.  
Bâtiment « le Mercury »  
Parc Technologique de St  
Aubin  
Route de l'Orme  
(CD 128)  
91190 SAINT-AUBIN  
FRANCE  
Tel. from France:  
01 60 19 80 00  
From other countries:  
33 1 60 19 80 00

### GERMANY

HONEYWELL AG  
Kaiserleistrasse 39  
D-63067 OFFENBACH  
GERMANY  
Tel.: 49 69 80 64444

### HUNGARY

HONEYWELL Kft  
Gogol u 13  
H-1133 BUDAPEST  
HUNGARY  
Tel.: 36 1 451 43 00

### ICELAND

HONEYWELL  
Hataekni .hf  
Armuli 26  
PO Box 8336  
128 reykjavik  
Iceland  
Tel.: 354 588 5000

### ITALY

HONEYWELL S.p.A.  
Via P. Gobetti, 2/b  
20063 Cernusco Sul  
Naviglio  
ITALY  
Tel.: 39 02 92146 1

### MEXICO

HONEYWELL S.A. DE  
CV  
AV. CONSTITUYENTES  
900  
COL. LOMAS ALTAS  
11950 MEXICO CITY  
MEXICO  
Tel.: 52 5 259 1966

### THE NETHERLANDS

HONEYWELL BV  
Laaderhoogtweg 18  
1101 EA AMSTERDAM  
ZO  
THE NETHERLANDS  
Tel.: 31 20 56 56 911

### NORWAY

HONEYWELL A/S  
Askerveien 61  
PO Box 263  
N-1371 ASKER  
NORWAY  
Tel.: 47 66 76 20 00

### POLAND

HONEYWELL Sp.z.o.o  
Ul Domainewksa 41  
02-672 WARSAW  
POLAND  
Tel.: 48 22 606 09 00

### PORTUGAL

HONEYWELL  
PORTUGAL LDA  
Edificio Suecia II  
Av. do Forte nr 3 - Piso 3  
2795 CARNAXIDE  
PORTUGAL  
Tel.: 351 1 424 50 00

### REPUBLIC OF IRELAND

HONEYWELL  
Unit 1  
Robinhood Business  
Park  
Robinhood Road  
DUBLIN 22  
Republic of Ireland  
Tel.: 353 1 4565944

### REPUBLIC OF SINGAPORE

HONEYWELL PTE LTD  
BLOCK 750E CHAI  
CHEE ROAD  
06-01 CHAI CHEE IND.  
PARK  
1646 SINGAPORE  
REP. OF SINGAPORE  
Tel.: 65 2490 100

### REPUBLIC OF SOUTH AFRICA

HONEYWELL  
Southern Africa  
PO BOX 138  
Milnerton 7435  
REPUBLIC OF SOUTH  
AFRICA  
Tel.: 27 11 805 12 01

### ROMANIA

HONEYWELL Office  
Bucharest  
147 Aurel Vlaicu Str.,  
Sc.Z.,  
Apt 61/62  
R-72921 Bucharest  
ROMANIA  
Tel.: 40-1 211 00 76/  
211 79

### RUSSIA

HONEYWELL INC  
4 th Floor Administrative  
Building of AO "Luzhniki"  
Management  
24 Luzhniki  
119048 Moscow  
RUSSIA  
Tel.: 7 095 796 98 00/01

### SLOVAKIA

HONEYWELL Ltd  
Mlynske nivy 73  
PO Box 75  
820 07 BRATISLAVA 27  
SLOVAKIA  
Tel.: 421 7 52 47 400/  
425

### SPAIN

HONEYWELL S.A  
Factory  
Josefa Valcarcel, 24  
28027 MADRID  
SPAIN  
Tel.: 34 91 31 3 61 00

### SWEDEN

HONEYWELL A.B.  
S-127 86 Skarholmen  
STOCKHOLM  
SWEDEN  
Tel.: 46 8 775 55 00

### SWITZERLAND

HONEYWELL A.G.  
Hertistrasse 2  
8304 WALLISELLEN  
SWITZERLAND  
Tel.: 41 1 831 02 71

### TURKEY

HONEYWELL  
Otomasyon ve Kontrol  
Sistemlen San ve Tic  
A.S.  
(Honeywell Turkey A.S.)  
Emirhan Cad No 144  
Barbaros Plaza C. Blok  
Kat 18  
Dikilitas 80700 Istanbul  
TURKEY  
Tel.: 90-212 258 18 30

### UNITED KINGDOM

HONEYWELL  
Unit 1,2 &4 Zodiac House  
Calleva Park  
Aldermaston  
Berkshire RG7 8HW  
UNITED KINGDOM  
Tel.: 44 118 906 2600

### U.S.A.

HONEYWELL INC.  
INDUSTRIAL PROCESS  
CONTROLS  
1100 VIRGINIA DRIVE  
PA 19034-3260  
FT. WASHINGTON  
U.S.A.  
Tel.: 1-800-343-0228

### VENEZUELA

HONEYWELL CA  
APARTADO 61314  
1060 CARACAS  
VENEZUELA  
Tel.: 58 2 239 0211







**Honeywell**

---

**Industrial Measurement and Control**

Honeywell  
1100 Virginia Drive  
Fort Washington, PA 19034

70-82-25-113 0303 Printed in USA

[www.honeywell.com/imc](http://www.honeywell.com/imc)