

## Series 61 and Series 62 Modutrol IV™ Motors

### PRODUCT DATA

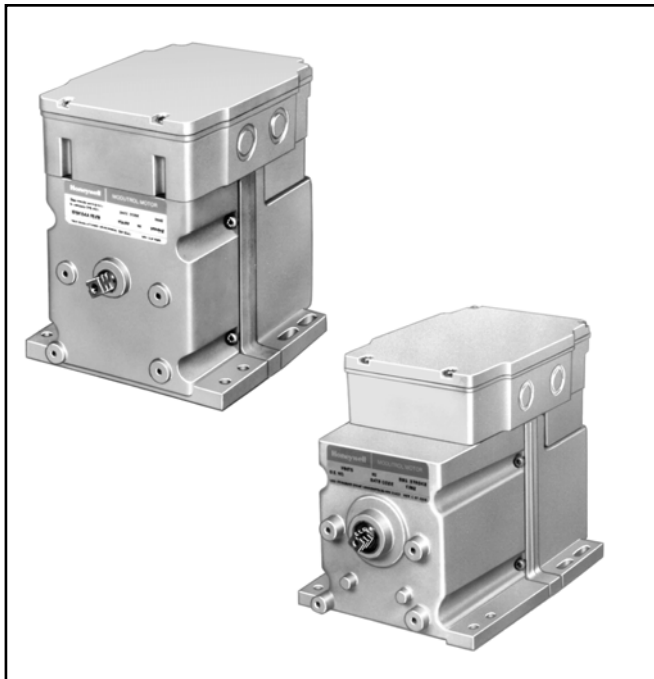

### FEATURES

- Directly replaces M644, M944B,E,G,H,J,K,R,S and M945B,C,G,K,L,AD Motors.
- Oil-immersed motor and gear train for reliable performance and long life.
- Junction box provides NEMA 3 weather protection.
- Motor and circuitry operate from 24 Vac. Models available with factory-installed transformer, or a field-added internal transformer.
- Quick-connect terminals standard; screw terminal adapter available.
- Adapter bracket for matching shaft height of older motors standard with replacement motors.
- Field-adjustable stroke (90° to 160°) models available.
- Nominal standard timing of 30 seconds for 90° stroke and 60 seconds for 160° stroke. Other timings available.
- Die-cast aluminum housing.
- Integral auxiliary switches available factory mounted, or can be field added to TRADELINE® models.
- Integral spring returns motor shaft to normal position (fully open or fully closed, depending on model) upon power interruption.
- Series 62 models include electrically isolated feedback potentiometer that provides shaft position indication.
- Series 62 TRADELINE models have linear feedback, configurable for slaving Series 90 Motors.
- Spring return motors can operate valve linkages from power end or auxiliary end shafts for normally closed or normally open valve applications.

### APPLICATION

The Series 61 and Series 62 Modutrol IV™ Motors are three-wire spring return and non-spring return floating control motors. Use these motors with controllers that provide a switched spdt or floating output to operate dampers or valves. The Series 62 motors also have an internal electrically isolated feedback potentiometer that provides indication of the motor shaft position and can be used for slaving Series 90 Motors or rebalancing an external control circuit.

### Contents

Application .....	1
Features .....	1
Specifications .....	2
Ordering Information .....	2
Installation .....	5
Settings and Adjustments .....	8
Operation .....	11
Checkout .....	12
Replacement .....	12



# SPECIFICATIONS

TRADELINE models have auxiliary switch cams.

## TRADELINE® Models:

TRADELINE models are selected and packaged to provide ease of stocking, ease of handling and maximum replacement value. Specifications are the same as those of standard models unless specified.

## Modutrol IV Order Number Guide:

See Table 1.

## Dimensions:

See Fig. 1.

**Table 1. Modutrol IV Order Number Guide.**

<b>M</b>	Motor					
<b>61</b>	Floating Control					
<b>62</b>	Floating Control with feedback					
<b>6</b>	—		35 lb-in. Non-Spring Return			
<b>7</b>	25 lb-in. Spring Return		75 lb-in. Non-Spring Return			
<b>8</b>	60 lb-in. Spring Return		150 lb-in. Non-Spring Return			
<b>9</b>	—		300 lb-in. Non-Spring Return			
<b>1</b>	Single-ended shaft	Non-Spring Return				
<b>2</b>		Normally Closed <sup>a</sup> Spring Return				
<b>3</b>		Normally Open <sup>b</sup> Spring Return				
<b>4</b>	Dual-ended shaft	Non-Spring Return				
<b>5</b>		Normally Closed <sup>a</sup> Spring Return				
<b>6</b>		Normally Open <sup>b</sup> Spring Return				
<b>A</b>	0 Aux. Switches	Fixed Stroke	Normally Closed <sup>a</sup>			
<b>B</b>	1 Aux. Switch	Adjustable Stroke				
<b>C</b>	2 Aux. Switches					
<b>D</b>	0 Aux. Switch					
<b>E</b>	1 Aux. Switch	Fixed Stroke	Normally Open <sup>b</sup>			
<b>F</b>	2 Aux. Switches					
<b>G</b>	0 Aux. Switch					
<b>H</b>	1 Aux. Switch	Adjustable Stroke				
<b>J</b>	2 Aux. Switches					
<b>K</b>	0 Aux. Switch					
<b>L</b>	1 Aux. Switch	Adjustable Stroke				
<b>M</b>	2 Aux. Switches					
<b>M</b>	<b>61</b>	<b>8</b>	<b>4</b>	<b>A</b>	<b>XXXX</b>	Varies with Model

<sup>a</sup> Electrically normally closed. Shaft rotates clockwise (as viewed from the power end) with increase in control signal. Motor drives to normally closed position when powered with control wiring not connected.

<sup>b</sup> Electrically normally open. Shaft rotates counterclockwise (as viewed from the power end) with increase in control signal. Motor drives to normally open position when powered with control wiring not connected.

# ORDERING INFORMATION

When purchasing replacement and modernization products from your TRADELINE® wholesaler or distributor, refer to the TRADELINE® Catalog or price sheets for complete ordering number.

If you have additional questions, need further information, or would like to comment on our products or services, please write or phone:

1. Your local Home and Building Control Sales Office (check white pages of your phone directory).
2. Home and Building Control Customer Logistics  
Honeywell Inc., 1885 Douglas Drive North  
Minneapolis, Minnesota 55422-4386 (612) 951-1000

In Canada—Honeywell Limited/Honeywell Limitée, 155 Gordon Baker Road, North York, Ontario M2H 3N7.  
International Sales and Service Offices in all principal cities of the world. Manufacturing in Australia, Canada, Finland, France, Germany, Japan, Mexico, Netherlands, Spain, Taiwan, United Kingdom, U.S.A.

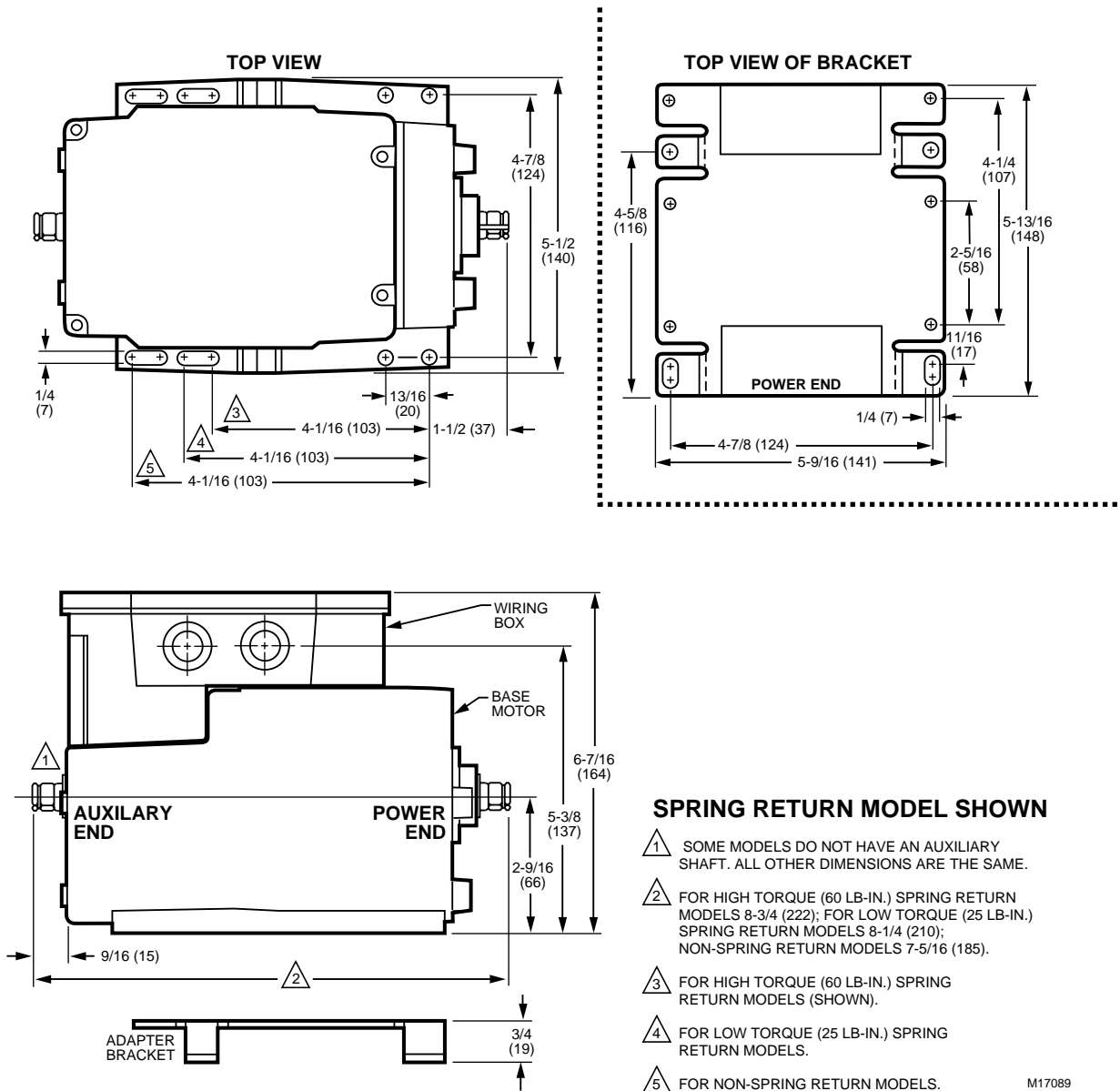

Fig. 1. Series 61 and 62 Modutrol IV Motor mounting dimensions in in. (mm).

**Electrical Ratings:**  
See Table 2.

**Table 2. Series 61 and 62 Modutrol Motor Power Consumption Ratings.**

Internal Transformer	Voltage at 50/60 Hz	Power Consumption			
		Non-Spring Return		Spring Return	
		(VA)	(W)	(VA)	(W)
No	24	17	15	21	20
Yes	24	26	20	30	25
	120	26	20	30	25
	208	26	20	30	25
	240	27	20	34	25

**Auxiliary Switch Ratings:**  
See Table 3.

**Table 3. Auxiliary Switch Ratings.**

Single Contact Rating <sup>a</sup>	120V (in Amps)	240V (in Amps)
Full Load	7.2	3.6
Locked Rotor	43.2	21.6

<sup>a</sup>40 VA pilot duty, 120/240 Vac on opposite contact.

**Control Inputs:**

Floating three-wire (Series 60): drive open, hold, drive closed. Series 62 models include an internal, electrically isolated feedback potentiometer that provides shaft position indication.

**Ambient Temperature Ratings:**

Maximum: 150°F (66°C) at 25% duty cycle.  
 Minimum: -40°F (-40°C).

**Feedback Potentiometer (Series 62 Models Only):**

TRADELINE Models (Can be shunted for slaving a Series 90 Motor):

160° Stroke: 600 ohms.

90° Stroke: 353 ohms.

All other models have potentiometer shunted to 115 ohms.

**Dead Weight Load On Shaft:**

Power or Auxiliary End: 200 lb (90.8 kg) maximum.  
 Maximum Combined Load: 300 lb (136 kg). (Dual shaft motors only.)

**Crankshaft:**

3/8 in. (9.5 mm) square. (Some models have double-ended shafts.)

**Stroke:**

Fixed Stroke Models: Available 90° or 160°.

Adjustable Stroke Models: Available field-adjustable from 90° to 160°. (See Stroke Setting procedure.)

**Timing And Torque:**

See Table 4.

**Approvals:**

Underwriters Laboratories Inc. Listed: File No. E4436, Guide No. XAPX.

Canadian Standards Association Certified: General Listed file no. LR1620, guide no. 400-E.

**Accessories:**

198162AA Internal Transformer; 120/208/240 Vac 50/60 Hz primary, 24 Vac secondary.

198162EA Internal Transformer; 120 Vac 50/60 Hz primary, 24 Vac secondary.

198162GA Internal Transformer; 220 Vac 50/60 Hz primary, 24 Vac secondary.

198162JA Internal Transformer; 24 Vac 50/60 Hz primary, 24 Vac secondary (for electrical isolation).

220736A Internal Auxiliary Switch Kit; one switch, can be field-installed on TRADELINE models.

220736B Internal Auxiliary Switch Kit; two switches, can be field-installed on TRADELINE models.

220741A Screw Terminal Adapter converts the standard quick-connect terminals to screw terminals.

221455A Infinitely Adjustable Crank Arm, can rotate through downward position and clear base of motor without requiring use of adapter bracket.

4074ERU Weatherproofing Kit provides NEMA 3 rating for Modutrol IV Motors mounted in position other than upright.

4074EZE Bag Assembly with parts that can provide CE compliance.

7617ADW Crank Arm, can rotate through downward position and clear base of motor without requiring use of adapter bracket.

ES650-117 Explosion-Proof Housing encloses motor for use in explosive atmospheres. Not for use with Q5001 (or any other valve linkages). Order separately from O-Z/Gedney Inc. To order, contact: O-Z/Gedney, Nelson Enclosures and Controls, (918) 641-7381 or (918) 641-7374; or write to: O-Z/Gedney, Nelson Enclosures and Controls P.O. Box 471650 Tulsa, OK 74147-1650 (Requires Honeywell 7617DM Coupling.)

Q100 Linkage connects Modutrol Motor to V51 Butterfly Valve. Requires the 220738A Adapter Bracket.

Q181 Auxiliary Potentiometer for sequence or unison control of 1 to 4 additional modulating (Series 90) motors.

Q5001 Bracket and Linkage Assembly connects Modutrol Motor to water or steam valve.

Q605 Damper Linkage connects motor to damper. Includes motor crank arm.

Q607 External Auxiliary Switch controls auxiliary equipment as a function of motor position.

NOTE: Torque designation corresponds to torque rating at standard timing (nominally 60 seconds for 160° and 30 seconds for 90° *except* for 300 lb-in. motors that have timings of 2 or 4 minutes).

**IMPORTANT**

*Never use Modutrol Motor continuously at the Breakaway Torque rating.*

**Table 4. Series 61 and 62 Modutrol Motor Timing and Torque Ratings.**

Nominal Timing <sup>a</sup> in sec		Rated Torque in lb-in. (N•m) <sup>b</sup>			
		Normal Running Torque		Breakaway Torque <sup>c</sup>	
90° Stroke	160° Stroke	Spring Return	Non-Spring Return	Spring Return	Non-Spring Return
15	30	—	75 (8.5)	—	150 (17.0)
30	60	25 (2.8)		50 (5.7)	
		60 (6.8)	35 (4.0)	120 (13.6)	70 (7.9)
			150 (17.0)		300 (34.0)
60	120	25 (2.8)	300 (34.0)	50 (5.7)	600 (68.0)
120	240	—		150 (17.0)	

<sup>a</sup> Timings apply to all TRADELINE models. Some OEM models are available with non-standard timing/torque.

<sup>b</sup> Torque ratings for dual-ended shaft motors are the sum of the shaft torques (power-end torque plus auxiliary-end torque).

<sup>c</sup> Breakaway torque is the maximum torque available to overcome occasional large loads such as a seized damper or valve.

## INSTALLATION

### When Installing this Product...

1. Read these instructions carefully. Failure to follow them could damage the product or cause a hazardous condition.
2. Check the ratings given in the instructions and on the product to make sure the product is suitable for your application.
3. Installer must be a trained, experienced service technician.
4. After installation is complete, check out product operation as provided in these instructions.



### CAUTION

**Electrical Shock or Equipment Damage Hazard.**  
Can shock individuals or short equipment circuitry.

Disconnect all power supplies before installation. Motors with auxiliary switches can have more than one disconnect.



### CAUTION

**Equipment Damage Hazard.**  
Can damage the motor beyond repair.  
Never turn the motor shaft by hand or with a wrench. Forcibly turning the motor shaft damages the gear train and stroke limit contacts.

### IMPORTANT

*Always conduct a thorough checkout when installation is complete.*

### Location



### CAUTION

**Motor Damage Hazard.**  
Deteriorating vapors and acid fumes can damage metal parts.

Install motor in areas free of acid fumes and other deteriorating vapors.

In excessive salt environments, mounting base and screws should be zinc or cadmium plated, not stainless steel or brass. Use the 220738A Adapter Bracket for mounting on these surfaces.

Allow enough clearance for installing accessories and servicing the motor when selecting a location (see Fig. 1). If located outdoors, use liquid-tight conduit connectors with the junction box to provide NEMA 3 weather protection. If mounted outdoors in a position other than upright, install a 4074ERU Weatherproofing Kit and liquid-tight connectors to provide NEMA 3 protection.

### Mounting

Use the following guidelines for proper motor mounting:

- Always install motors with the crankshaft horizontal.
- Mounting flanges extending from motor housing base are drilled for 1/4 inch (6.4 mm) machine screws or bolts.
- Non-Spring Return Motors are shipped from the factory in the closed position (at the limit of counterclockwise rotation, as viewed from the power end of the motor).

- Spring Return Motors are shipped from the factory in their normal position.
- Normally closed models are shipped at the limit of counterclockwise rotation, as viewed from the power end of the motor.
- Normally open models are shipped at the limit of clockwise rotation, as viewed from the power end of the motor.

NOTE: Refer to Fig. 2 for graphical representation of fully-open and fully-closed positions.

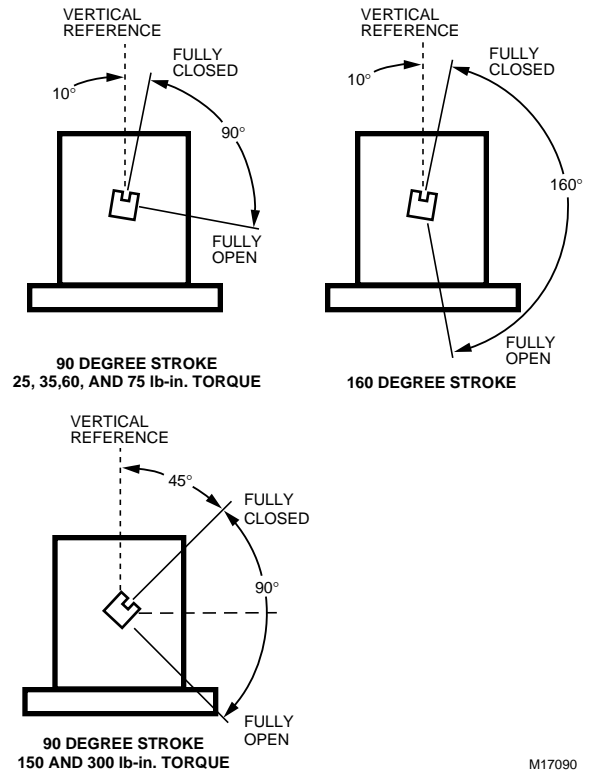

Fig. 2. Motor shaft positions at stroke limits (viewed from power end of motor).

### Adapter Bracket

The 220738A Adapter Bracket, positioned between the motor and the equipment, raises motor shaft height by 0.75 in. (19 mm) to match that of previous Modutrol® Motor models.

The following applications require this bracket:

- Q607 External Auxiliary Switch.
- Damper linkage applications require added clearance to allow:
  - Crank arm rotation through the downward position.
  - Sufficient damper linkage to reach the motor shaft.
- All valve linkages except the Q5001.

NOTE: When the bracket is not used in a replacement application, the damper linkage requires adjustment for the new shaft position.

To mount the motor with the bracket:

1. Mount the bracket to the equipment with existing or standard bolts.
2. Using the provided bolts, mount the motor to the bracket threaded holes. See Fig. 3.

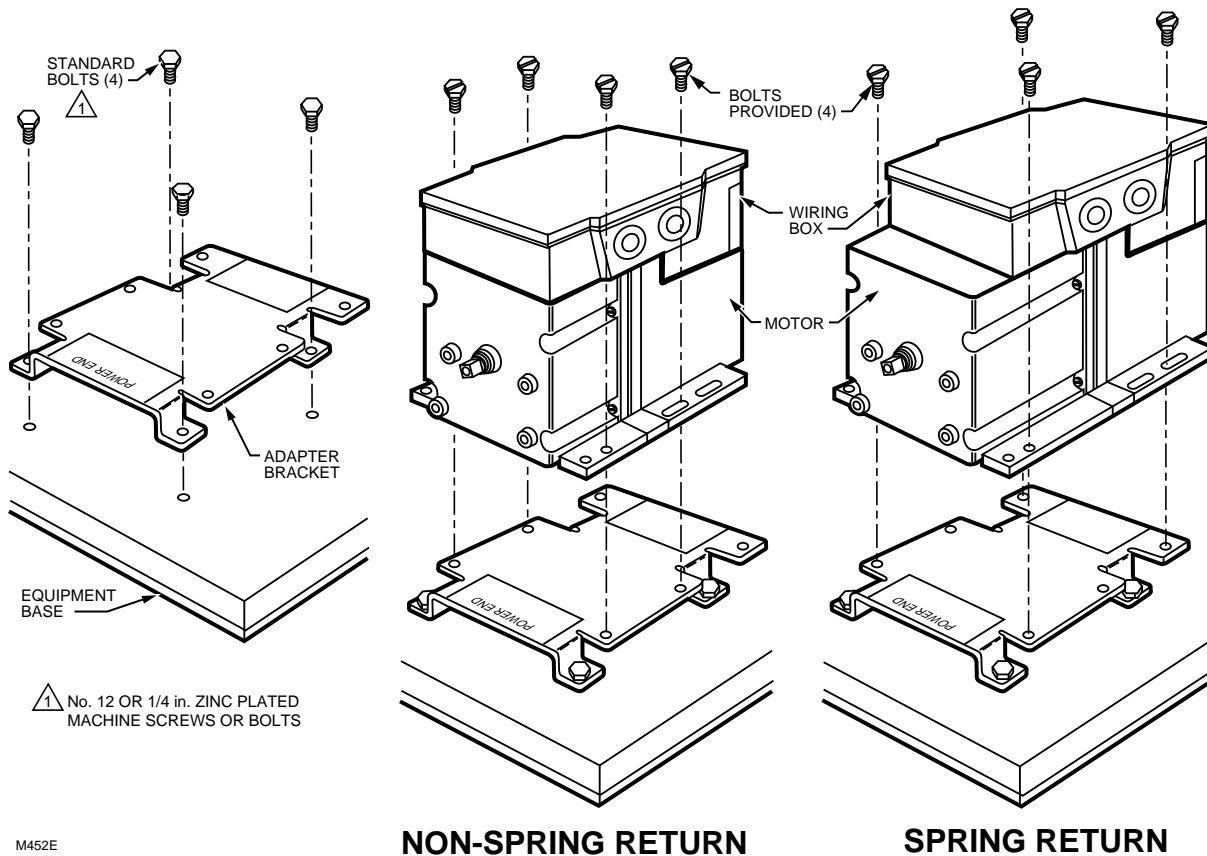

Fig. 3. Mounting the motor with an adapter bracket.

For valve linkage applications (other than the Q5001):

1. Mount the bracket to the linkage.
2. Position the motor on the bracket to align the motor shaft with the linkage.
3. Attach the motor to the bracket with the four bolts provided. See Fig. 4.

### Damper Linkages

The motor does not include a crank arm. Order the crank arm separately (see Accessories in the Specifications section). For detailed instructions on the assembly of specific linkages, refer to the Installation Instructions packed with the linkage.

### CAUTION

**Equipment Damage Hazard.**

**Stalling a motor can damage the drive shaft.**

Ensure installation of motors and linkages allows the motor to drive through full stroke without obstruction.

### Valve Linkages

The Q100 Linkage requires the 220738A Adapter Bracket for all valve applications. Applications with the Q5001 Valve Linkage do not require the 220738A Adapter Bracket (see Fig. 4).

### Junction Box

When used with liquid-tight conduit connectors, the junction box provides NEMA 3 weather protection for the motor. The junction box, standard with replacement motors, encloses the terminals and provides knockouts for wiring conduits.

Housing an internal transformer or internal auxiliary switches requires using a junction box.

### Wiring

### CAUTION

**Electrical Shock or Equipment Damage Hazard. Can shock individuals or short equipment circuitry.**

Disconnect power supply before installation.

### IMPORTANT

*All wiring must agree with applicable codes, ordinances and regulations.*

1. Ensure that the voltage and frequency stamped on the motor correspond with the power supply characteristics.
2. When connecting several motors in parallel, ensure that the power supply VA rating is large enough to provide power to all motors used without overloading.
3. Fig. 5 shows that the motor terminals are quick-connects located on top of the printed circuit board.
4. To access the wiring compartment:
  - a. Remove the four screws from the junction box top.
  - b. Lift off the cover.
5. Refer to Fig. 6 through 8 for typical wiring, and Fig. 9 for internal auxiliary switch connections.

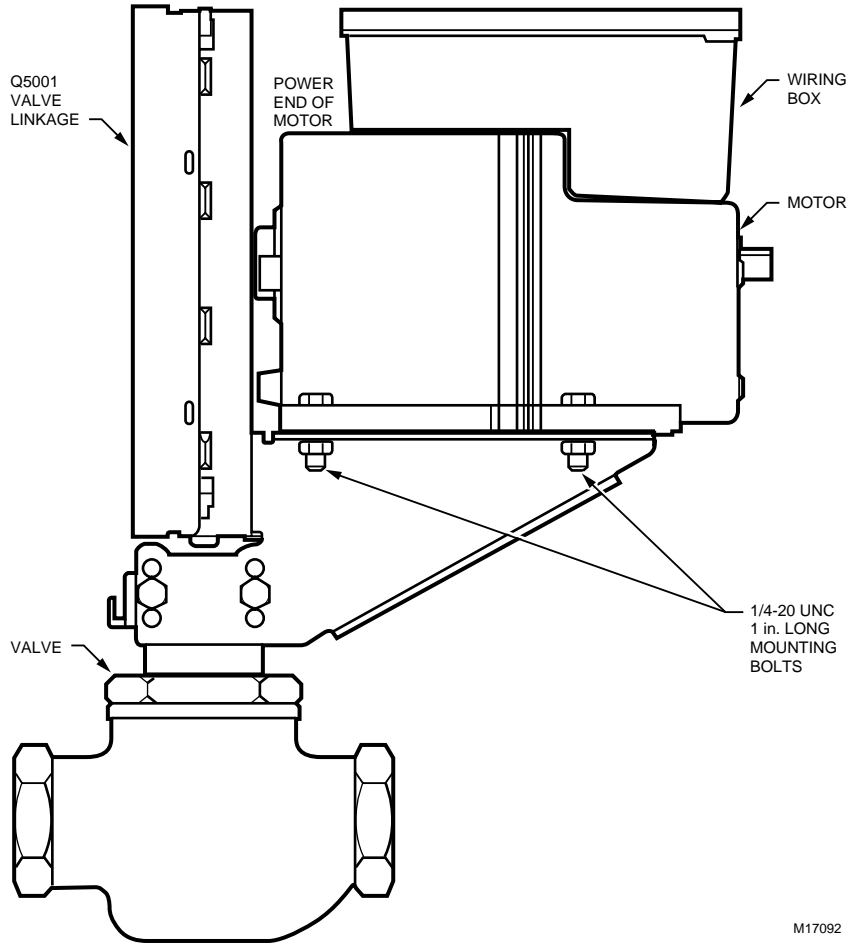
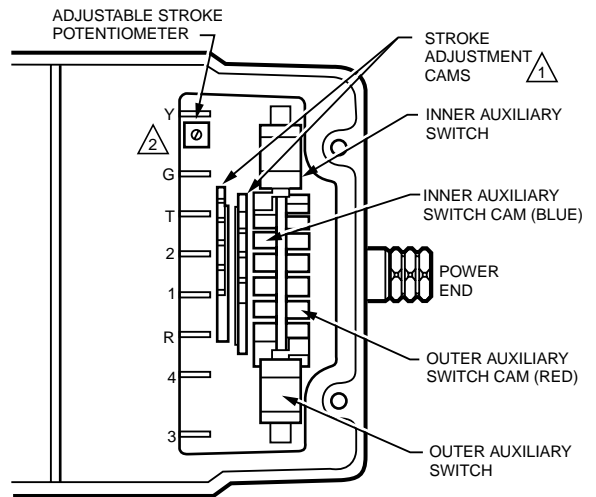

Fig. 4. Mounting the motor on a Q5001 Valve Linkage.

NOTE: Reverse motor rotation by switching wires at either the motor or the panel. Reverse rotation on the Series 61 models by reversing the wires at terminals W and B. Reverse rotation on the Series 62 models by reversing wires at terminals 1 and 2 (to correct the motor rotation) and reverse wires at terminals Y and G (to maintain a feedback signal that corresponds with the shaft rotation).



① HIGH TORQUE (150 lb.-in., 300 lb.-in.) MODELS HAVE TWO YELLOW ADJUSTMENT CAMS. LOW TORQUE MODELS HAVE ONLY ONE BROWN INTERNAL STROKE ADJUSTMENT CAM.

② SERIES 62 TERMINAL DESIGNATIONS SHOWN.

NOTE: NOT ALL FEATURES AVAILABLE ON ALL MODELS.

M17094

Fig. 5. Terminals and adjustments.

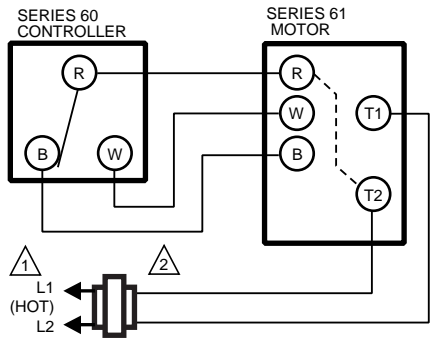

- 1 POWER SUPPLY. PROVIDE DISCONNECT MEANS AND OVERLOAD PROTECTION AS REQUIRED.
- 2 TRANSFORMER MAY BE INTERNAL OR EXTERNAL TO MOTOR.

Fig. 6. Series 61 motor wiring.

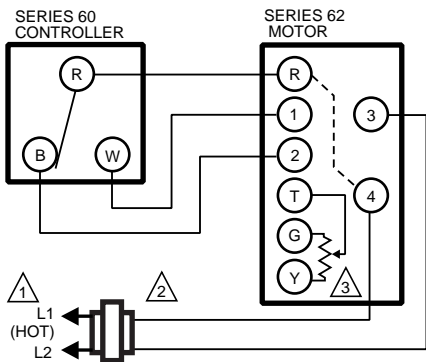

- 1 POWER SUPPLY. PROVIDE DISCONNECT MEANS AND OVERLOAD PROTECTION AS REQUIRED.
- 2 TRANSFORMER MAY BE INTERNAL OR EXTERNAL TO MOTOR.
- 3 FEEDBACK POTENTIOMETER.

Fig. 7. Series 62 motor wiring.

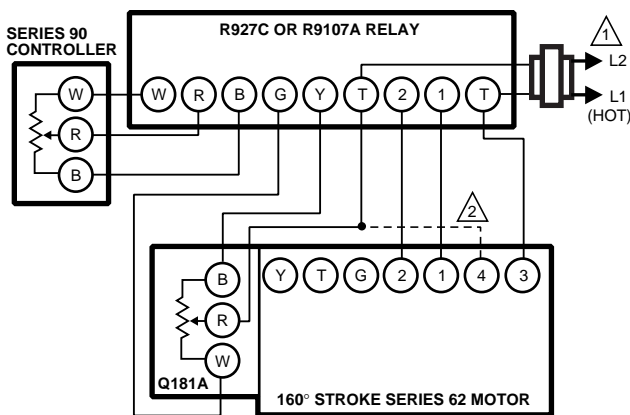

- 1 POWER SUPPLY. PROVIDE DISCONNECT MEANS AND OVERLOAD PROTECTION AS REQUIRED.
- 2 CONNECTION REQUIRED ONLY FOR SPRING RETURN MOTORS.

Fig. 8. Connections to R927C or R9107A Relay.

NOTE: Vibration does not affect the performance of Modutrol IV Motors (as it did in earlier Modutrol Motors). When replacing a motor that was connected to an R927C or R9107A Relay, Honeywell recommends performing a retrofit to remove the relay and the old motor. Replace both with one Series 90 Modutrol IV motor (that is, do not replace the relay).

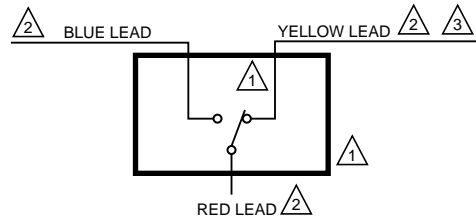

- 1 USE NEC CLASS 1 WIRING UNLESS POWER SUPPLY MEETS CLASS 2 REQUIREMENTS. TAPE UNUSED LEADS. ENSURE THE CURRENT DRAW OF THE EXTERNAL CIRCUIT IS LESS THAN SWITCH CONTACT RATING.
- 2 ON TWO-SWITCH MOTORS, SECOND SWITCH HAS BLACK LEADS WITH BLUE, YELLOW, AND RED TRACERS.
- 3 YELLOW LEAD NOT PRESENT ON ALL MOTORS.

Fig. 9. Auxiliary switch schematic.

## SETTINGS AND ADJUSTMENTS

### Adjustable Stroke

On adjustable stroke motors, stroke is field-adjustable between 90° and 160°.

- The mechanical adjustment (cams) establishes the fully open (clockwise, as viewed from the power end) and fully closed positions of the motor shaft.
- The electrical adjustment (trim potentiometer) matches the feedback resistance change to the motor stroke.
- TRADELINE® motors are shipped with the stroke set at 160°.

### CAUTION

**Careless Installation Hazard.**

**Use of excessive force while adjusting cams damages the motor.**

To avoid damaging motor end switches, set cams by moving only the top of the screwdriver.

### CAUTION

**Careless Installation Hazard.**

**Forcibly turning the motor shaft damages the gear train and stroke limit contacts.**

Never turn the motor shaft manually (by hand or with a wrench).

### Before Setting Stroke

1. Remove the top cover from the motor.
2. Disconnect the controller from the motor.
3. For models with an internal transformer (line voltage motors), ensure that power (and nothing else) remains connected to the motor.



**IMPORTANT**

*Detach the linkage from motor before adjusting the stroke.*

**Setting Stroke at 90° or 160°**

1. Adjust the trim potentiometer:
  - a. For 160° stroke, turn fully clockwise.
  - b. For 90° stroke, turn fully counterclockwise.
2. Drive the motor to the mid-position as follows:
  - a. For models with an internal transformer (line voltage motors), connect a jumper across terminals R and 2 to drive motor open (clockwise, as viewed from power end), or across terminals R and 1 to drive motor closed (counterclockwise) until motor reaches mid-position.
  - b. For models with no internal transformer (low voltage motors), connect 24 Vac across motor terminals 2 and 3 to drive motor open (clockwise, as viewed from the power end), or across terminals 1 and 3 to drive motor closed (counterclockwise) until motor reaches mid-position.
3. Insert 1/8 in. screwdriver blade into a slot on inner cam and proceed as follows:
  - a. For 90° stroke: Move the top of the screwdriver as far as possible counterclockwise (viewed from the power end).
  - b. For 160° stroke: Move the top of the screwdriver as far as possible clockwise (viewed from the power end).

See Fig. 10. Repeat in successive cam slots until the inner cam is against the stop.

NOTE: For low torque motors (75 lb-in. or less), omit step 4 and proceed to step 5.

4. Insert 1/8 in. screwdriver blade into a slot on outer cam and proceed as follows:
  - a. For 90° stroke: Move the top of the screwdriver as far as possible clockwise (viewed from the power end).
  - b. For 160° stroke: Move the top of the screwdriver as far as possible counterclockwise (viewed from the power end).

See Fig. 10. Repeat in successive cam slots until the outer cam is against the stop.

5. Check the motor stroke before connecting the linkage.
6. Reconnect the controller, replace the motor top cover and attach the linkage to the motor.

**Setting Stroke Between 90° and 160°**

1. Adjust the trim potentiometer fully clockwise.
2. Drive the motor to the mid-position as follows:
  - a. For models with an internal transformer (line voltage motors), connect a jumper across terminals R and 2 to drive motor open (clockwise, as viewed from power end), or across terminals R and 1 to drive motor closed (counterclockwise) until motor reaches mid-position.
  - b. For models with no internal transformer (low voltage motors), connect 24 Vac across motor terminals 2 and 3 to drive motor open (clockwise, as viewed from the power end), or across terminals 1 and 3 to drive motor closed (counterclockwise) until motor reaches mid-position.

3. Insert 1/8 in. screwdriver blade into a slot on inner cam and move the top of the screwdriver as far as possible clockwise (viewed from the power end). See Fig. 10. Repeat in successive cam slots until the inner cam is against the clockwise stop.
4. Drive the motor to the fully-open position as follows:
  - a. For models with an internal transformer (line voltage motors), connect a jumper across terminals R and 2 until the motor reaches the fully-open position.
  - b. For models with no internal transformer (low voltage motors), connect 24 Vac across motor terminals 2 and 3 until motor reaches the fully-open position.

NOTE: The motor should now be in the 90° position.

**IMPORTANT**

*During step 5, allow the motor to reposition after each move of the cam.*

5. Insert 1/8 in. screwdriver blade into a slot on inner cam and move the top of the screwdriver slowly clockwise (viewed from the power end). Repeat this procedure until the motor reaches the desired fully-open position.

NOTE: Each click of the cam provides approximately 2 degrees of rotation.

**IMPORTANT**

*If the motor turns past the desired position, do not move the cam.*

6. If the motor turns past the desired position, drive the motor to mid-position then move the cam clockwise to the stop and repeat steps 4 and 5.

NOTE: Drive the motor to mid-position as follows:

- a. For models with an internal transformer (line voltage motors), connect a jumper across terminals R and 2 to drive motor open (clockwise, as viewed from power end), or across terminals R and 1 to drive motor closed (counterclockwise) until motor reaches mid-position.
- b. For models with no internal transformer (low voltage motors), connect 24 Vac across motor terminals 2 and 3 to drive motor open (clockwise, as viewed from the power end), or across terminals 1 and 3 to drive motor closed (counterclockwise) until motor reaches mid-position.

7. Once the desired position is reached, set the electrical stroke limit:

- a. Slowly adjust the trim potentiometer counterclockwise until the motor starts to move.
- b. Stop and turn the trim potentiometer 1/8 turn clockwise.

NOTE: This last adjustment ensures total motor movement over the full range of the controller.

8. Check that the electrical stroke is set properly by opening the W lead. The motor should not move.

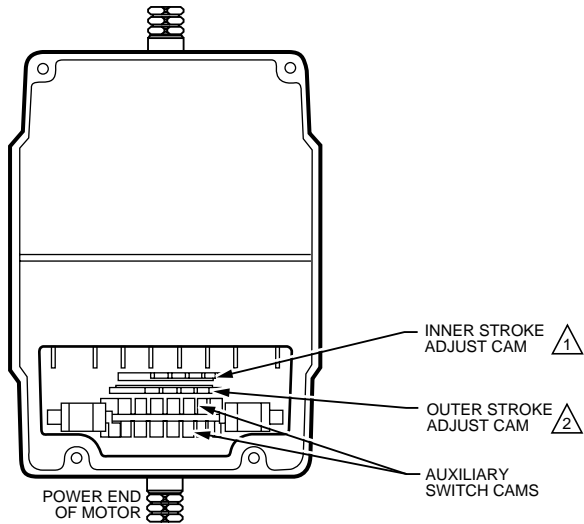

MOVE SCREWDRIVER AT TOP ONLY TO ADJUST CAM.

1/8 INCH STRAIGHT-BLADE SCREWDRIVER

CAM

M17100

TORQUE	NO. OF CAMS	CAM COLOR
HIGH	2	YELLOW
LOW	1	BROWN

OUTER STROKE ADJUST CAM IS ONLY PRESENT ON HIGH TORQUE MOTORS.

Fig. 10. Stroke adjustment setup for non-spring return models.

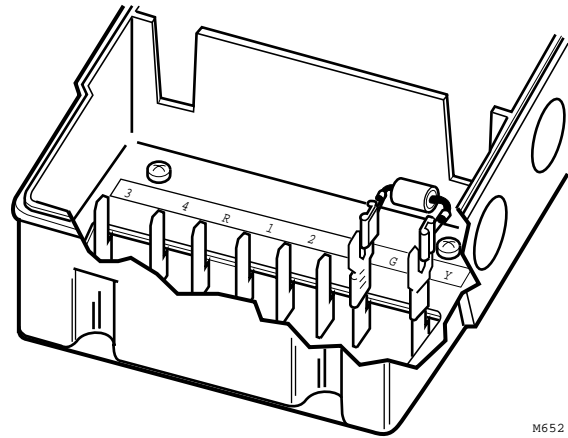

Fig. 11. Attaching a shunt resistor to TRADELINE motors.

### Auxiliary Switches

Adjustable cams actuate the auxiliary switches. These cams can be set to actuate the switches at any angle within the motor stroke. Select switch differential of 1° or 10°.

Motors with factory-added auxiliary switches are shipped in the closed position (fully counterclockwise, as viewed from the power end). Auxiliary cam default actuates the switches 30° from fully open with a 1° differential. With the motor in the closed (fully counterclockwise) position, the auxiliary switch breaks contacts R-B. See Fig. 9 (or the auxiliary switch Installation Instructions) for auxiliary switch wiring.

TRADELINE Motors are shipped with auxiliary switch cams that permit acceptance of 220736A,B Internal Auxiliary Switch Kits. Refer to form 63-2228 for 220736A,B installation instructions.

### Auxiliary Switch Adjustment

#### IMPORTANT

When adjusting the auxiliary switch cams use the following procedure:

1. Insert 1/8 in. screwdriver blade into a slot on cam and move the top of the screwdriver as far as possible in the required direction. See Fig. 12.
2. Repeat step 1 in successive cam slots until the cam is in the required position.

Use the following procedure to obtain the desired auxiliary switch settings:

1. Remove the top cover from the motor to gain access to the motor terminals and auxiliary cams.
2. Disconnect the controller from the motor.
3. Drive the motor to the position where the auxiliary equipment is to be switched as follows:
  - a. For Non-Spring Return models without a transformer, connect 24 Vac to motor terminals 2 and 3 to drive motor open (clockwise as viewed from the power end), or to terminals 1 and 3 to drive motor closed (counterclockwise).
  - b. For Non-Spring Return models with a transformer, jumper across terminals R and 2 to drive motor open (clockwise as viewed from the power end), or across terminals R and 1 to drive motor closed (counterclockwise).

### Feedback Potentiometer Configuration (Series 62 TRADELINE® Motors Only)

Select and install one of the four shunt resistors to obtain the appropriate feedback characteristic for your application. See Specifications section for details on feedback resistance without a shunt resistor.

- Linear feedback provides linear indication of shaft position with no shunt resistor. With no shunt resistor, full stroke feedback resistance is 600 ohms for 160° stroke motors and 355 ohms for 90° stroke motors.
- W902 Control requires full stroke feedback resistance of 115 ohms. Select and attach the proper shunt resistor across terminals Y and G (see Table 5 and Fig. 11). Use the white shunt resistor for 160° stroke motors; use the green shunt resistor for 90° stroke motors.
- Slaving a Series 90 Motor requires full stroke feedback resistance of 142 ohms. Select and attach the proper shunt resistor across terminals Y and G (see Table 5 and Fig. 11). Use the red shunt resistor for 160° stroke motors; use the purple shunt resistor for 90° stroke motors.

Table 5. Shunt Resistor Selections.

Stroke	Linear Feedback	W902 Control <sup>a</sup>	Slaving Series 90 Motor
90°	None	Green (174 ohms)	Purple (274 ohms)
160°	None	White (143 ohms)	Red (187 ohms)

<sup>a</sup> Note that the W902 Control is obsolete, replaced by the W964F, which does not require a feedback signal.

- c. For Spring Return models, connect a jumper across motor terminals 2 and 4 to drive the motor open, or across motor terminals 1 and 4 to drive the motor closed.
- 4. Once Modutrol Motor reaches correct position, disconnect the jumper.
- 5. For a switch differential of 1°, check continuity of the auxiliary switch contacts R-B and rotate the cam as follows:
  - a. If the contacts are open, rotate the cam clockwise until the R-B contacts close.
  - b. If the contacts are closed, rotate the cam counterclockwise until the R-B contacts open.
- 6. For a switch differential of 10°:
  - a. For Spring Return models, rotate the cam approximately 180° so the slow-rise portion of the cam actuates the switch. Then check continuity of the auxiliary switch contacts R-B.
  - b. For Non-Spring Return models, check continuity of the auxiliary switch contacts R-B.
- 7. Rotate the cam as follows:
  - a. If the contacts are open, rotate the cam counterclockwise until the R-B contacts close.
  - b. If the contacts are closed, rotate the cam clockwise until the R-B contacts open.
- 8. Check for the proper differential and switching of the auxiliary equipment by driving the motor through the full stroke in both directions.
- 9. Disconnect the jumper, reconnect the controller, and replace the top cover on the motor.

**NOTE:** Changing the differential from 1° to 10° reverses the switching action. For example, with a 10° differential, switch contacts R-B make and R-W break on a counterclockwise (closed) rotation. With a 1° differential, switch contacts R-W make and R-B break on a counterclockwise (closed) rotation.

## OPERATION

Use Series 61 and Series 62 Modutrol IV Motors for standard Series 60 operation (drive open, hold, drive closed). Series 62 Motors can also be used with the feedback potentiometer as an input to the controller.

See Table 6 for details on motor response to controller signals.

**NOTE:** Reverse the wires at either the motor or the controller.

To reverse the rotation direction of a non-spring return motor:

1. Reverse the wires at terminals 1 and 2.
2. Reverse the wires at terminals Y and G.

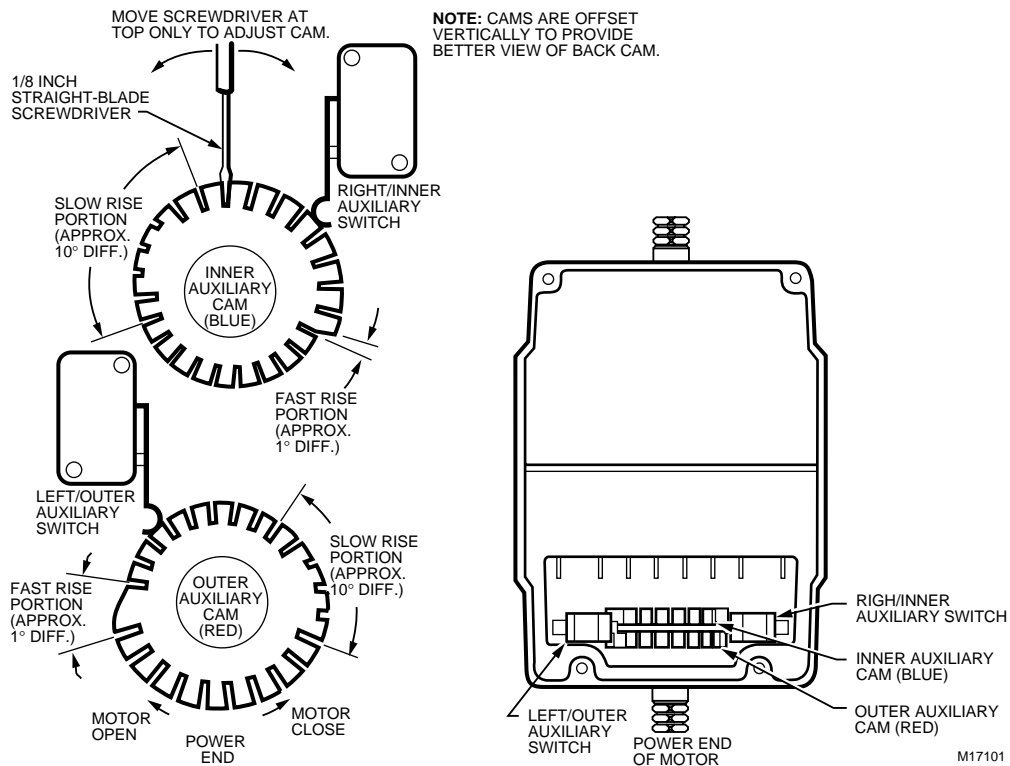

**Fig. 12. Auxiliary switch adjustment.**

**Table 6. Modutrol IV Motor Operation.**

Motor Type	Terminal Connection		Resulting Action
	Series 61	Series 62	
Non-Spring Return or Spring Return	R-W	4-1	ccw (closed)
	R-B	4-2	cw (open)
Non-Spring Return	None	None	stops (none)
Spring Return	—	None	spring return (closed)

## CHECKOUT

After the installation and linkage adjustment, check the entire motor and control hookup. Proper checkout ensures that:

- The motor operates the load (damper or valve) properly.
- The motor responds properly to the controller as the input varies. See Table 6.
- The auxiliary switch, if used, operates at the desired point of motor rotation.

1. Inspect the motor, linkage, and valve or damper to ensure all mechanical connections are correct and secure.

**NOTE:** In damper installations, the pushrod should not extend more than a few inches past the ball joints.

2. Ensure that there is adequate clearance for the linkage throughout the entire motor stroke without binding or striking other objects.
3. Drive the motor fully open and fully closed. See Table 6.

**NOTE:** Refer to controller or system instructions for additional checkout procedures.

4. For spring return motors, ensure that the valve or damper returns to its normal position when power is interrupted.

5. Return the controller to the desired setting before leaving the job.

## REPLACEMENT

### Damper Application

1. Turn off power and remove wiring from the old motor.
2. Remove the crank arm from the shaft of the old motor and remove the old motor.
3. Determine necessity of the mounting bracket. If the linkage can reach the new motor shaft position and the crank arm has clearance for the necessary rotation, the bracket is not required. Use the 220738A Adapter Bracket or the 221455A Crank Arm if the crank arm must rotate through the bottom plane of the motor.
  - a. If no bracket is required, mount the new motor directly to the equipment and refer to the Installation, Settings and Adjustments, and the Operation and Checkout sections.
  - b. If the bracket is required, refer to the Adapter Bracket section and Fig. 3 in addition to the Installation, Settings and Adjustments, and the Operation and Checkout sections.
4. Use No. 12 or 1/4 inch machine screws or bolts to mount the new motor.
5. Mount damper crank arm and linkage to the new motor shaft.
6. Use the Checkout procedures to test the crank arm and linkage adjustment.

### Valve Application

When replacing a motor in a valve application, the linkage type determines the necessity for the 220738A Adapter Bracket. With Q100, Q601 or Q618 Linkages, it is necessary to use the 220738A to raise the motor shaft to the appropriate height. Valve applications with a Q5001 Linkage do not require the 220738A Adapter Bracket. To operate Honeywell V5011 two-way or V5013 three-way valves through full stroke, use a 160° stroke motor.

#### Home and Building Control

Honeywell Inc.  
Honeywell Plaza  
P.O. Box 524  
Minneapolis MN 55408-0524

#### Honeywell Latin American Region

480 Sawgrass Corporate Parkway  
Suite 200  
Sunrise FL 33325

#### Home and Building Control

Honeywell Limited-Honeywell Limitée  
155 Gordon Baker Road  
North York, Ontario  
M2H 3N7

#### Honeywell Europe S.A.

3 Avenue du Bourget  
1140 Brussels  
Belgium

#### Honeywell Asia Pacific Inc.

Room 3213-3225  
Sun Hung Kai Centre  
No. 30 Harbour Road  
Wanchai  
Hong Kong

**Honeywell**

