

HercuLine® 10260S Smart Actuator

Specification

Overview

Honeywell's **HercuLine® 10260S Smart** actuators incorporate all of the high quality and reliable features of the traditional **HercuLine®** actuators plus the added benefits of a microprocessor-based enhanced electronics unit (EEU). These additional benefits provide:

- Faster set-up and commissioning
- Network capability
- Health parameter monitoring for proactive maintenance planning.

HercuLine 10260S Smart actuators enable operation at maximum process efficiency, minimal downtime, and access to all actuator parameters for real-time business decisions.

Honeywell's 10260S actuators are industrial rated and engineered for very precise positioning of dampers and valves. The HercuLine 10260S performs especially well in extremely demanding environments requiring continuous duty, high reliability, and low maintenance. Typical applications are furnace pressure dampers, gas/air valves, windbox dampers, coal mill dampers, and more.



Figure 1 HercuLine 10260S Smart Actuator

Actuator Operation

Microprocessor-based electronics continually monitor the performance, health, and position of the actuator for repeatable positioning and response to demand signal. When instructed to move, the enhanced electronics unit fires the appropriate triac on the motor drive circuit to position the motor. Actuator position sensing is via a non-contact position sensor that is continually monitored by the electronics.

Spur gears and a single reduction worm/worm gear combine with a synchronous AC induction motor for accurate and repeatable positioning of final control elements.

Features

Performance —

- **Accurate Positioning** – Motor/gear train provides accurate positioning with almost instantaneous start/stop characteristics.
- **Non-Contact Position Sensing** – Non-contacting sensing lowers maintenance costs and improves performance.
- **Duty Cycle** – Continuous duty cycle motor. No burn out.
- **Full Travel Speed** – Full stroke travel speeds from 10 to 60 seconds (90 degree travel, 60 Hz supply).

- **Torque** – High torque capability in small package (10 to 300 lb-ft).
- **High Accuracy** – Typically 0.25 % of 90° span.
- **High Repeatability** - Typically 0.2 % of 90° span
- **Characterization** – Programmable linear, equal percentage, quick opening, or user configured 10-point characterization allows tailoring of control for specific applications.
- **Input Filter Setting** – Four programmable combinations of input filter settings are provided to accommodate various customers needs. The combinations are none, spike, low pass, or spike + low pass filter.
- **Deadband** – Deadband is programmable between the values of 0.2 % to 5 % of 90° span.

Features (continued)

Operation —

- **Control Signals** – 0/4 to 20 mA, 0/1 to 5 Vdc, 0 to 10 Vdc, Digital RS485 Modbus RTU protocol, and Series 90 control.
- **Output Signals** – 0/4 to 20 mA, 0/1 to 5 Vdc and slidewire emulation.
- **Power Requirements** – Low power consumption 120/240 Vac, 50/60 Hz, single phase ≤ 1 Amp.
- **Manual Operation** – All 10260S series actuators are supplied with a manual handwheel to operate the actuator when power is not available.
- **Auto-Manual** – electric handswitch with auxiliary contacts indicating an "Out-of-Auto" position is available for local electric control.
- **RS485/Modbus RTU Communication** – Simple and easy to use Modbus RTU communication is standard with all 10260S actuators allowing seamless networking of Honeywell control products.
- **Auxiliary Outputs** – Two types of auxiliary outputs can be specified, SPDT switches or electromechanical relay outputs. Relay outputs can be programmed to output alarm conditions, provide control of other equipment, or indicate status.
- **Alarm Functions** – Alarms may be assigned to relay outputs or may be accessed through Modbus. Alarms can be triggered from stall, temperature limits, motor cycle count, out of automatic mode, digital input, position, input failure, position sensor failure, power up failure, and more.

- **Local HMI Configuration** – An integral keypad and high intensity display is available for non-intrusive local configuration of the actuator (Figure 2).
- **Configuration security** – Password protection is provided, allowing users to lock out some, all, or no groups of setup parameters to prevent tampering.
- **Factory Calibration** – Factory calibration is stored in non-volatile memory and can be restored via the local HMI at any time.
- **Direction of rotation** – Direction of rotation on increasing input signal is programmable.
- **Split range operation** – Split range is programmable and infinitely adjustable.
- **Digital Input Override** – A digital input is provided and is programmable to provide override of all other input signals as an emergency override of control. The digital input can be programmed to drive the actuator open, closed, remain in-place, or to a user specified position on contact closure.
- **Failsafe** – When input signal exceeds high or low range limits (or input signal failure), the actuator can be programmed to drive open, closed, remain in-place, or drive to a user specified position.

Construction —

- **Enclosure** – Rugged, industrial grade enclosure.
- **Low Maintenance** – Simple-proven design means high reliability/low maintenance.
- **Output Shaft Hardware** – All 10260S series actuators are supplied with an adjustable radius and adjustable position crank arm. Optional 12" crank arm, linkage kits, and direct coupling hardware are available.

- **Limit Switches** – Two end-of-travel electric limit switches are supplied as standard equipment with all 10260S series actuators.
- **Warranty** – Exceptional warranty
- **Certification** – CSA, UL (Future) CE available.

Health Monitoring

A standard feature on all 10260S actuators accumulates information about actuator operation. The information then can be used to evaluate and determine predicted or scheduled maintenance periods. Parameters monitored are accumulated stall time, exceeded thermal operating rating of the actuator, and number of motor starts in a region of travel, total travel and current actuator travel.

Non-Contact Position Sensing

Honeywell 10260S series actuators implement a variable inductance, non-contact position sensor mounted directly to the actuator output shaft providing precision position sensing from 0 to 90 degrees (Figure 3). This technology eliminates maintenance items such as wipers, bearings, as well as static friction, hysteresis and electrical noise over a wide range of demanding environmental conditions.

Slidewire Emulation

The Slidewire Emulation Circuit (SEC) emulates the proportional voltage output of a typical slidewire through a high impedance circuit. The voltage output is proportional to the supply voltage and shaft position. A non-contact position sensor is used to determine shaft position in place of the slidewire.

Local Display and Keypad

Configuration and set-up is through the local HMI, consisting of a display and keypad interface (Figure 2). A high intensity 10-character LED display and simple push buttons provide quick access for actuator set up and status information. A PC configurator allowing remote configuration will be available in early 2001. If relay outputs are specified, all configuration can be done through either the local HMI interface or the PC configurator. If mechanical switches are specified, then the user must manually set the auxiliary output.

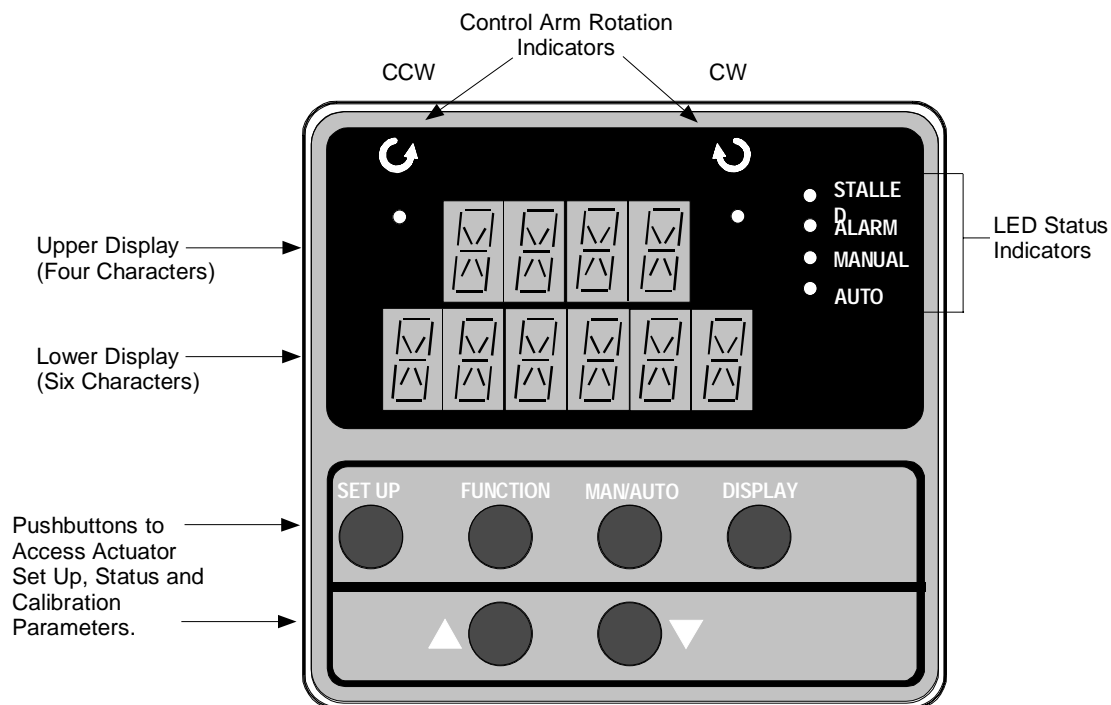

Figure 2 Local HMI (Display and Keypad)

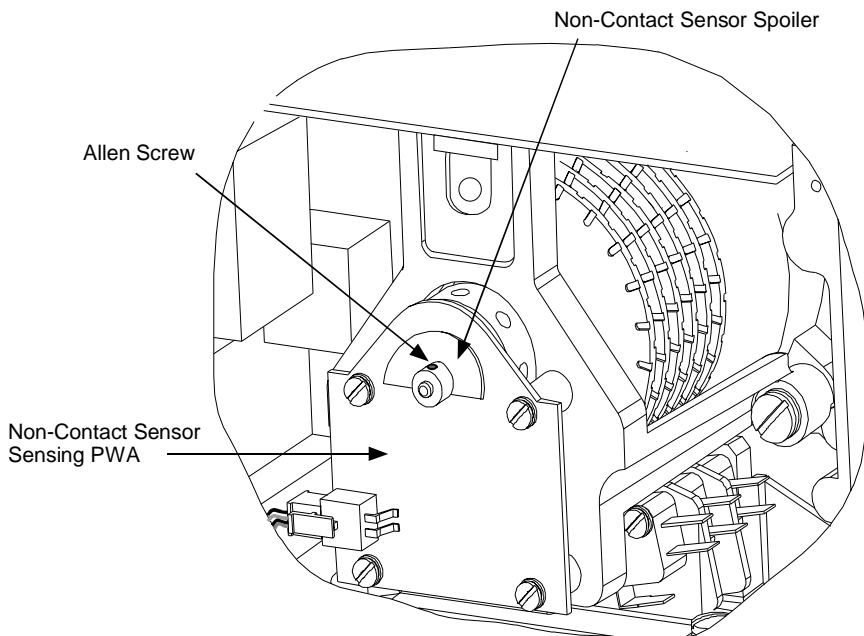

Figure 3 Non-Contact Sensor Assembly

Set Up/Configuration Parameters

Configuration parameters are logically grouped and accessed using the local HMI. Actuator calibration is also accomplished through a simple procedure using the keypad. By pressing the SETUP button on the HMI, you can step through the set up groups that contain all of the configuration parameters. The table below summarizes the configuration parameters available within the various set up groups. Full details of all configuration parameters are found in the *10260S Series Smart Actuator Installation, Operation and Maintenance Manual*, document number 62-86-25-08.

Set Up Group	Configuration Parameter Selections/Settings												
<p>SET INPUT— Selects various parameters that define actuator operation.</p>	<table style="width: 100%; border: none;"> <tr> <td style="width: 50%;">IN TYP – Input Actuation Type</td> <td style="width: 50%;">Dband – Input Deadband</td> </tr> <tr> <td>INP HI – Input High Range Value</td> <td>FsTYP – Failsafe Type</td> </tr> <tr> <td>INP LO – Input Low Range Value</td> <td>FsVAL – Failsafe Value</td> </tr> <tr> <td>FILTYP – Input Filter Type</td> <td>CHAR – Input Characterization</td> </tr> <tr> <td>LPFILT – Low Pass Filter Time Constant</td> <td>RESTYP – Restore Calibration Type</td> </tr> <tr> <td>Direct – Actuator Rotation</td> <td></td> </tr> </table>	IN TYP – Input Actuation Type	Dband – Input Deadband	INP HI – Input High Range Value	FsTYP – Failsafe Type	INP LO – Input Low Range Value	FsVAL – Failsafe Value	FILTYP – Input Filter Type	CHAR – Input Characterization	LPFILT – Low Pass Filter Time Constant	RESTYP – Restore Calibration Type	Direct – Actuator Rotation	
IN TYP – Input Actuation Type	Dband – Input Deadband												
INP HI – Input High Range Value	FsTYP – Failsafe Type												
INP LO – Input Low Range Value	FsVAL – Failsafe Value												
FILTYP – Input Filter Type	CHAR – Input Characterization												
LPFILT – Low Pass Filter Time Constant	RESTYP – Restore Calibration Type												
Direct – Actuator Rotation													
<p>SET RELAY— When the actuator is equipped with optional relays, this set up group allows you to set relay action for various actuator operating conditions. Contact closure can be wired to external annunciators or alarm points to indicate conditions for any of the RelayTypes.</p>	<table style="width: 100%; border: none;"> <tr> <td style="width: 50%;"> RTYPn – Relay Type Input Range Position Range Deviation Upper or Lower Limit Travel Temperature High or Low Cycle Count Motor Stalled Manual Mode Power Up Test Failure Input Signal Failure Position Sensor Signal Failure Digital Input Closure </td> <td style="width: 50%;"> RnnVAL – Relay Value Rnn HL – Relay High/Low RLYnHY – Relay Hysteresis </td> </tr> </table>	RTYPn – Relay Type Input Range Position Range Deviation Upper or Lower Limit Travel Temperature High or Low Cycle Count Motor Stalled Manual Mode Power Up Test Failure Input Signal Failure Position Sensor Signal Failure Digital Input Closure	RnnVAL – Relay Value Rnn HL – Relay High/Low RLYnHY – Relay Hysteresis										
RTYPn – Relay Type Input Range Position Range Deviation Upper or Lower Limit Travel Temperature High or Low Cycle Count Motor Stalled Manual Mode Power Up Test Failure Input Signal Failure Position Sensor Signal Failure Digital Input Closure	RnnVAL – Relay Value Rnn HL – Relay High/Low RLYnHY – Relay Hysteresis												
<p>SET CUREOUT— Selects the current (or voltage) output range of the actuator.</p>	<p>CUREOUT - Output Signal Range</p> <table style="width: 100%; border: none;"> <tr> <td style="width: 50%;">4 – 20 mA</td> <td style="width: 50%;">0 – 20 mA</td> </tr> <tr> <td>1 – 5 V</td> <td>0 – 5 V</td> </tr> <tr> <td>SW E</td> <td></td> </tr> </table>	4 – 20 mA	0 – 20 mA	1 – 5 V	0 – 5 V	SW E							
4 – 20 mA	0 – 20 mA												
1 – 5 V	0 – 5 V												
SW E													
<p>SET COMM— Actuator can be defined as a master or slave device on a Modbus RTU RS-485 loop. Operating setpoint can be transmitted to the actuator and operating status can be read when connected to supervisory control systems.</p>	<p>COMM – Communications Parameters</p> <p>ADDRES – Device Address</p> <p>BAUD – Baud Rate</p> <p>XmtDLY – Response Delay</p> <p>DBLBYT – Floating Point Data Format</p>												
<p>SET DIGINP— Selects digital input action upon contact closure.</p>	<p>DIGINP – Digital Input State</p> <p>Endpos – End Position Value</p>												
<p>SET DISPLA— Selects desired decimal places and engineering units for local display</p>	<p>DECMAL – Decimal Point Location</p> <p>EUNITS – Units Display</p> <p>UNITS – Display Units</p>												
<p>CAL INPUT, MTR, CURENT— If needed, calibration of the actuator input, motor position and actuator output can be performed using the local keypad and display.</p>													

Continued on next page ⇒

Set Up Group	Configuration Parameter Selections/Settings	
SET LOCK — Enables lock out or access to selected set up group parameters and calibration values.	LOCKID – Set Security Password LOCK – Lock Out	
READ STATUS — Displays failsafe condition and the results of various diagnostics performed during power up.	FAILSF – Failsafe RAMTST – RAM Test Diagnostic SEETST – Serial EEPROM Test Diagnostic	CFGTST – Configuration Test Diagnostic CALTST – Calibration Test Diagnostic
SET DRVINP — Allows access to actuator device information.	VERSON – Firmware Version SPEED – Stroke Speed POWER – Power Input Voltage and Line Frequency TAG – Tag Name	MFGDAT – Manufacturing Date LREP – Date of Last Repair LCAL – Date of Last Field Calibration REPTYP – Repair Type
SET MAINT — Allows access to parameters that monitor operating conditions.	TEMP – Actuator Temperature TEMPHI – High Temperature Limit TEMPLO – Low Temperature Limit ACSTAL – Accumulated Stall Time	STARTS – Accumulated Motor Starts RLnCNTS – Relay Cycle Counts REGNn – Accumulated Motor Starts MANRST – Reset Maintenance Statistics

Specifications – General

Physical					
Weight	45 lb. (20.4 kg) net				
Enclosure	Precision-machined Aluminum alloy casting, finished in light gray powder coat epoxy.				
Gear Train	Alloy steel, high efficiency steel spur gear primary train with safety fused idler gear. Precision ground, self locking/self releasing worm gear final mesh.				
Mechanical Stops	To prevent over-travel.				
Operating Temperature	–30 °C to +75 °C (–20 °F to +170 °F)				
Storage Temperature	–40 °C to +93 °C (–40 °C to +200 °F)				
Relative Humidity	0 % to 99 % R.H. noncondensing over the full operating temperature range.				
Scale	0 % to 100 % corresponding to full crank arm travel.				
Crank Arm	Adjustable radii (1-7/16" to a maximum of 5"). Position adjustable through 360° rotation. Optional 12" crank arm adjustable 0 to 12" radii.				
Output Shaft	1" diameter, 1-1/2" long is standard on 10261S, 10262S, 10264S, 10266S, 10267S, 10268S. 1" diameter, 2" long is standard on 10263S, 10265S and 10269S optional on other models.				
Rotation	90° degrees between 0 % and 100 % on scale, limited by mechanical stops.				
Direction of Rotation	Field selectable via HMI.				
Manual Handwheel	Provides a means of positioning the actuator in the event of a power failure or set-up.				
Lubrication	Texaco Starplex 2 EP Grease				
Output Torque/Full Travel Stroking Time	Model #	Torque Lb-ft	N-M	Output Shaft Speed sec/90° @ 60Hz	@ 50Hz
	10261S	10	15	10	12
	10262S	20	27	20	24
	10264S	40	55	40	48
	10266S	60	80	60	72
	10267S	40	55	20	24
	10268S	80	110	40	48
	10269S	150	200	60	72
	10263S	200	270	40	48
	10265S	300	400	60	72

Specifications – General, Continued

Electrical			
Mains Supply	120 Vac single phase, 50 Hz or 60 Hz 240 Vac single phase, 50 Hz or 60 Hz		
Motor	Instant start/stop, non-coasting, non-burnout, continuous duty, permanent magnet, synchronous induction motor. Can be stalled up to 100 hours without damage.		
Motor Current	= No load = full load = locked rotor		
	Model No.	120 V, 50/60 Hz	240 V, 50/60 Hz
	10261S, 62S, 64S, 66S 10263S, 10265S 10267S, 68S, 69S	0.4 A (48 VA) 1.0 A (120 VA) 0.8 A (96 VA)	0.3 A (24 VA) 1.0 A (60 VA) 0.3 A (36 VA)
Fuses (Motor drive)	Wickmann USA #373-1160-0-41: 1.6 Amp Fast (2)		
Loss of Power	Stays in place.		
Local Auto/Manual Switch	Optional – Allows local and automatic operation of the actuator.		
Limit Switches	Standard – Two SPDT end of travel limits rated (10 A at 125 Vac, 5 A at 250 Vac).		
Auxiliary Switches/Relays	Optional – Up to 4 additional SPDT switches (or 4 relay outputs, programmable)		

Certifications	
Approvals	CE Compliance (<i>Optional</i>) CSA/UL (<i>Pending</i>) NEMA 4 (<i>Pending</i>)

Torque Settings of Crank Arm Bolts	
Clamp Bolt	<i>Standard Arm</i> (Part Number 087449) (1-7/16 to 5 in. adjustment): 85 lb-ft. <i>Optional Long Arm</i> (Part Number 154007) (0 to 12 in. adjustment): 85 lb-ft.
Rod End Bolt	<i>Standard and long arms</i> : 30-35 lb./ft

Specifications – Actuator

Electrical		
Input Signals	Analog: 0/4 to 20 mA (With supplied shunt resistor for current range: 250 ohms ± 0.1 % Part Number: 070756) 0/1 to 5 Vdc 0 to 10 Vdc Series 90 control Digital: Modbus RTU (RS485)	
Input Impedance	Input 0/4 to 20 mA 0/1 to 5 Vdc	Input Impedance 250 ohms 10 K ohms
Sensitivity	0.2 % to 5 % of 90° span, proportional to deadband	
Hysteresis	Less than 0.4 % of full scale	
Deadband	0.2 % to 5 % of 90° span, adjustable. Shipped at 0.5 %	
Repeatability	0.2 % of 90° span	
Voltage/ Supply Stability	0.25 % of span with +10/–15 % voltage change	
Temperature Coefficient	Less than ± 0.030 % of span per degree C for 0 °C to 50 °C Less than ± 0.05 % of span per degree C for –30 °C to 75 °C	
Zero Suppression	90 % of span.	
Input Filters	Selectable spike and low pass filters.	
Solid State Motor Control	Two triac switches for clockwise or counterclockwise motor operation. Transient voltage protection provided.	
Failsafe operation	If input signal exceeds configured input range. Selectable and adjustable.	
Feedback signals	0 to 20 mA, 4 to 20 mA 1 Vdc to 5 Vdc with 250 ohm resistor, (0 to 16 Vdc with 800 ohm resistor)	
Slidewire Emulation	Provides output voltage ratiometric to shaft position and potentiometric to supply voltage (1 Vdc to 20 Vdc) without a slidewire. Emulates a 100 ohm to 1000 ohm slidewire. 10 mA output maximum.	
Isolation	Input signal, output signal and power are isolated from each other.	
Load Requirement (4-20)	Current Out — 0 to 1000 ohms	
Programmable Functions	Selectable and configurable operating parameters: <ul style="list-style-type: none"> • Input range • Input filtering • Input characterization • Security • Digital Input action • Deadband • Failsafe on loss of input signal • Failsafe on loss of position sensor • Direction of rotation • Relay closure action • Communication parameters • Split range operation • Output range • Alarms 	

Turnbuckle Linkage Kits (Table V, Option E)

These kits are to be used where short lengths are required. These lengths range from 12 inches to 24 inches and refer to the rod end center-to-center distance. All turnbuckle kits include the turnbuckle, load rod end (left-hand thread), connecting rods and locking nuts. The nut and bolt to connect the rod end to the load are supplied by the Customer. The actuator rod end (right-hand thread), nut and bolt are supplied with the actuator.

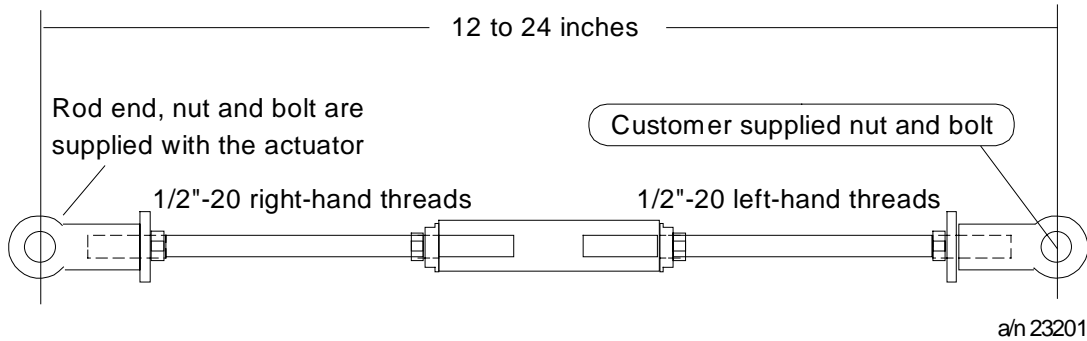
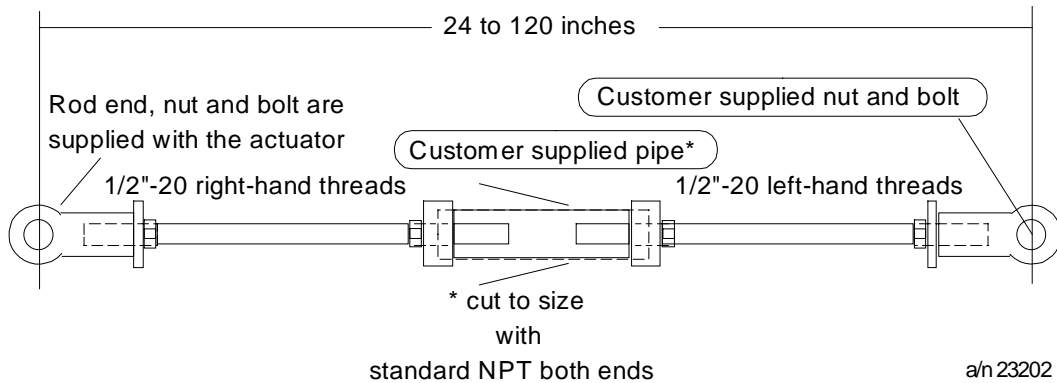

Figure 4 Turnbuckle Linkage Kit

Pipe Linkage Kits (Table V, Option E)

These kits are used for linkage lengths from 24 to 120 inches. All pipe linkage kits include the mechanical pipe couplings, load rod end (left-hand thread), connecting rods and locking nuts. The Customer must supply a piece of schedule 40 pipe* (Both ends with right-hand NP threads) and a nut and bolt to connect the rod end to the load. The actuator rod end (right-hand thread), nut and bolt are supplied with the actuator.



*Pipe length = Overall linkage length minus (-) 17 inches

Figure 5 Pipe Linkage Kit

Actuator Crank Arms

The 10260S Series Actuator comes standard with a 5-inch crank arm (Figure 6) and there is an optional 12-inch crank arm that is adjustable from 0 to 12 inches. The crank arm uses a standard 1/2" rod end to compliment the turnbuckle and pipe linkage kits.

For applications that use a link rod, a link rod adapter is available as an option in the Model Selection Guide.

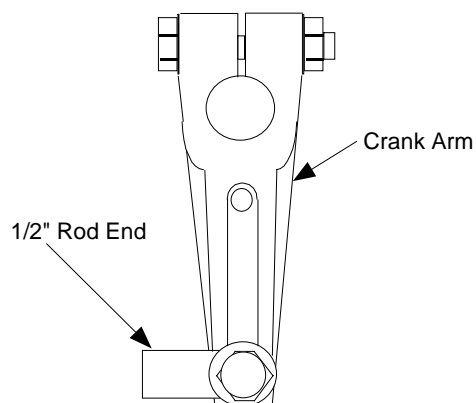

Figure 6 Standard 5" Crank Arm

Projecting Scale Option (Table V, Option B)

The projecting scale option is available for customers whose actuators are direct coupled or positioned such that it would be impossible to read the standard scale on the actuator. The projecting scale is attached to the actuator and is readable from a distance from the front side of the actuator as well as the normal shaft side of the actuator.

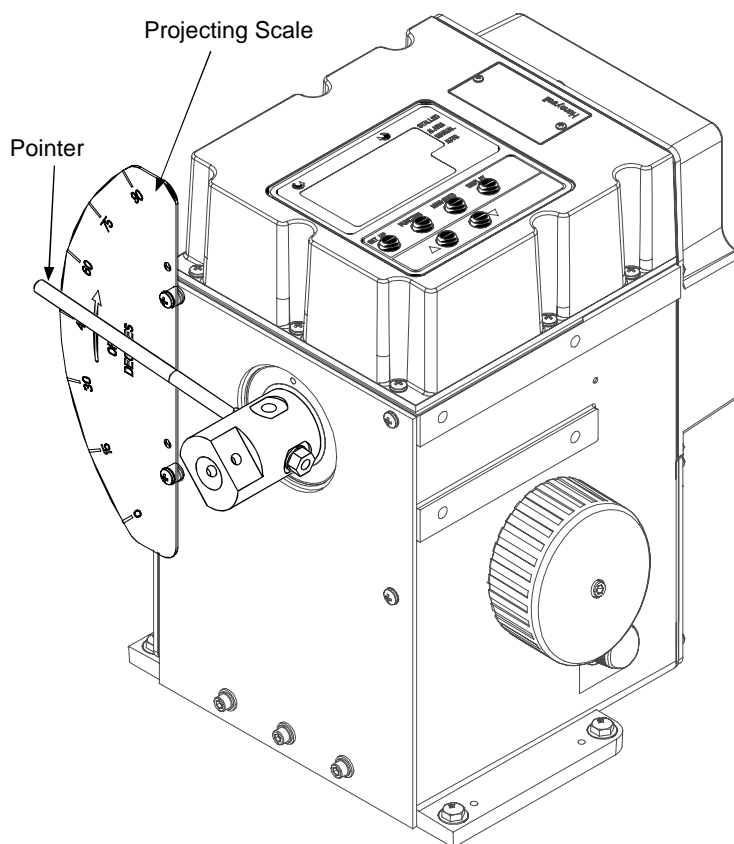

Figure 7 Projecting Scale Option

Model Selection Guide

Reference 62-86-16-19

Instructions

- Select the desired key number. The arrow to the right marks the selection available.
- Make the desired selections from Tables I thru VIII using the column below the arrow.
A dot (•) denotes unrestricted availability.

Key Number	I	II	III	IV	V	VI	VII	VIII
[] - []	[] - []	[] - []	[] - []	[] - []	[] - []	[] - []	[] - []	[] - []

KEY NUMBER - Torque and Speed Selection Availability

Output Torque (lb. - ft.) (N - M)	Full Travel Stroking - Time in Seconds		Selection	Availability
	60 Hz	50 Hz		
10 (15)	10	12	10261S	↓
20 (27)	20	24	10262S	↓
40 (55)	40	48	10264S	↓
60 (80)	60	72	10266S	↓
40 (55)	20	24	10267S	↓
80 (110)	40	48	10268S	↓
150 (200)	60	72	10269S	↓
200 (270)	40	48	10263S	↓
300 (400)	60	72	10265S	↓

TABLE I - POWER SUPPLY - SINGLE PHASE

120 VAC 60 Hz	Single Phase 120 VAC 60Hz Motor	1	•
120 VAC 50 Hz	Single Phase 120 VAC 50Hz Motor	2	•
220/240 VAC 60 Hz	Single Phase 220/240 VAC 60Hz Motor	3	•
220/240 VAC 50 Hz	Single Phase 220/240 VAC 50Hz Motor	4	•

TABLE II - ANALOG INPUT/OUTPUT SIGNALS

Input	4-20 mA, 0-20mA (1-5 Vdc, 0-5 Vdc, 1-10 Vdc, 0-10Vdc)	0XX	•
	0 - 135 Ohm (series 90 control)	2XX	a
Output	No Analog Position Output	X00	•
	4-20 mA, 0-20mA (1-5 Vdc, 0-5 Vdc, 1-10 Vdc, 0-10Vdc)	X20	•
	Slidewire Emulation	X40	•

TABLE III - SWITCH AND RELAY OUTPUTS (2 mech end-of-travel limits standard)

Auxiliary Switches and Relay Outputs	None	00X	•
	2 Aux. SPDT Switches	20X	•
	4 Aux. SPDT Switches	40X	•
	2 Aux. + 2 Programmable Relay Outputs	22X	•
	2 Programmable Relay Outputs	02X	•
	4 Programmable Relay Outputs	04X	•
Auto/Manual Switch	None	XX0	•
	One Auto/Manual Switch with Out-of-Auto Contact	XX1	•

TABLE IV - CONFIGURATION INTERFACE

Remote	None - requires PC interface	0	-
Local	Integrally mounted local display/keypad interface	1	•

TABLE V - COMMUNICATIONS/PROTOCOL

Selection Availability

Modbus RTU RS485	RS-485 Modbus compliant - standard with EEU	0	•
Additional Communications	Future	1	-

TABLE VI - OPTIONS

A	Shafts	Standard	0XXXX	•
		5 Inch Extension	1XXXX	b
		3 Inch Extension	3XXXX	b
B	Projecting Scale	None	X0XXX	•
		3/4 Inch Shaft Coupling	X1XXX	c
		3/4 Inch Shaft Coupling, CCW to Open	X2XXX	c
		1 Inch Shaft Coupling	X3XXX	c
		1 Inch Shaft Coupling, CCW to Open	X4XXX	c
		CW to Open, No Coupling	X5XXX	d
C	Crank Arm	5 Inch Standard	XX0XX	•
		None	XX1XX	•
		12 Inch	XX2XX	•
D	Rod Adapter	None	XXX0X	•
		3/8 Inch	XXX1X	•
		5/8 Inch	XXX2X	•
		7/16 Inch	XXX3X	•
		7/8 Inch	XXX4X	•
E	Linkage Kits	None	XXXX0	•
		12 to 16 Inch Turnbuckle Kit	XXXX1	•
		16 to 20 Inch Turnbuckle Kit	XXXX2	•
		20 to 24 Inch Turnbuckle Kit	XXXX3	•
		1 Inch Pipe Kit	XXXX4	•
		1.5 Inch Pipe Kit	XXXX5	•
	2 Inch Pipe Kit	XXXX6	•	

TABLE VII- OPTIONS

A	Weatherproof	None	0XX	•
		NEMA 4 - Future	1XX	-
B	Approvals	None	X0X	•
		UL/CSA - Future	X1X	-
		CE - Future	X2X	-
C	Tagging	None	XX0	•
		Linen (Note 1)	XX1	•
		Stainless Steel (Note 1)	XX2	•

TABLE VIII - FACTORY OPTIONS

A	Special Manuals	No Special Options (US Manual Standard)	0X	•
		English (European Format) - Future	1X	-
		French (European Format) - Future	2X	-
B	Other	None	X0	•
		Certificate of Conformance	X2	•
		Special instrument requirement - Future	XX	-

RESTRICTIONS

Restriction Letter	Table	Available Only With	Not Available With	
		Selection	Table	Selection
a	II	X00	II	020, X40
b	V	X0XXX	Key Number	10263A, 10265A, 10269A
c	V	0X100	Key Number	10263A, 10265A, 10269A
d	V	050XX, 060XX, 051XX, 061XX	Key Number	10263A, 10265A, 10269A

Note 1: Customer must supply tagging information - Up to 3 lines, 22 characters per line.

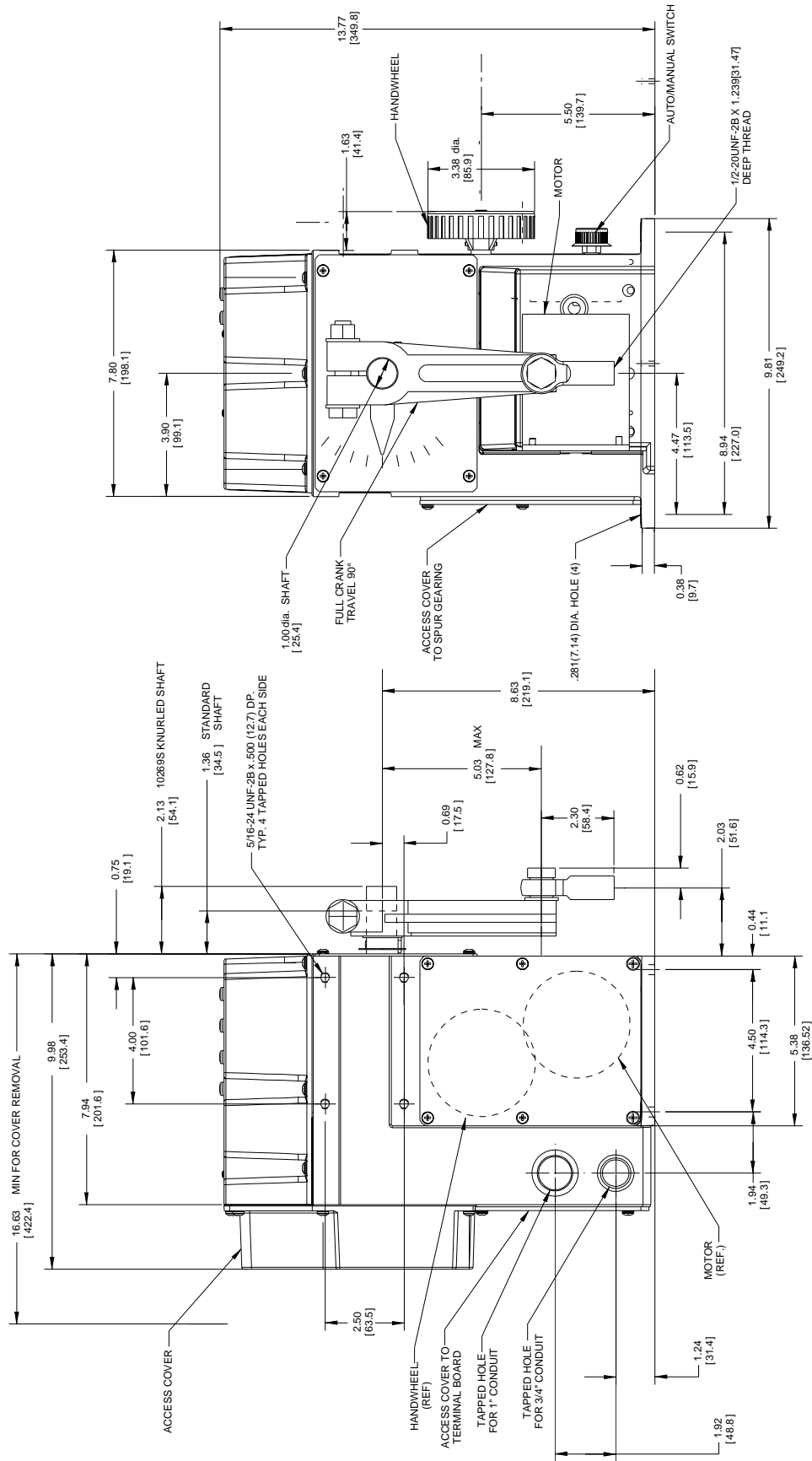

- NOTES:
1. ACTUATOR CAN BE MOUNTED IN ANY POSITION.
 2. PROVIDE ADEQUATE CLEARANCE AT ALL ACCESS COVERS FOR SERVICING AND ADJUSTMENTS.
 3. WIRING DIAGRAM IS LOCATED ON THE INSIDE OF THE TERMINAL BOARD COVER.

10260S INSTALLATION
 MODELS: 10261S, 10262S, 10264S, 10266S, 10267S, 10268S, 10269S

Outline and Dimensions of 10261S, -62S, -64S, -66S, -67S -68S and -69S Actuators

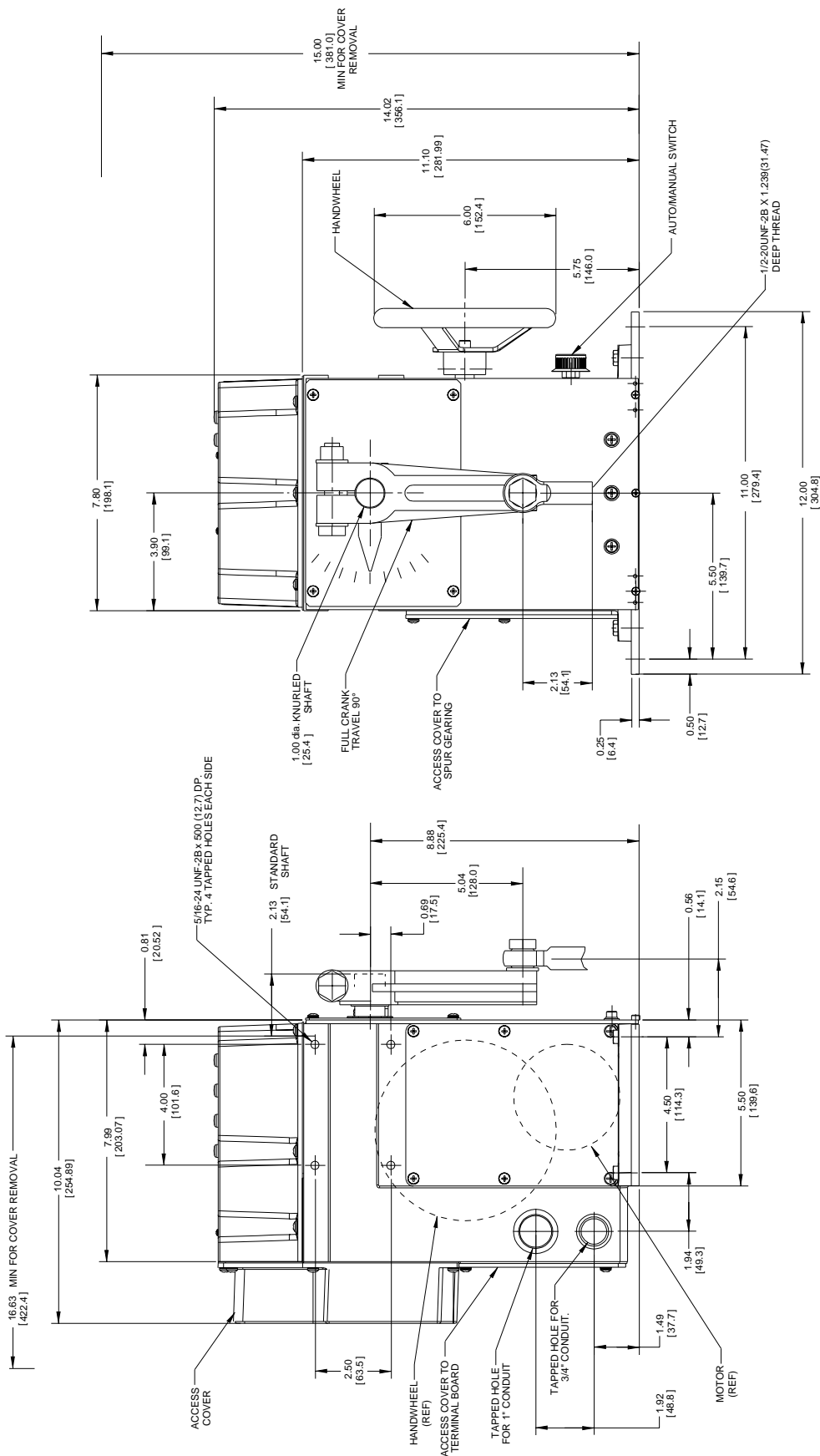

- NOTES:
1. ACTUATOR CAN BE MOUNTED IN ANY POSITION.
 2. PROVIDE ADEQUATE CLEARANCE AT ALL ACCESS COVERS FOR SERVICING AND ADJUSTMENTS.
 3. WIRING DIAGRAM IS LOCATED ON THE INSIDE OF THE TERMINAL BOARD ACCESS COVER.

10260S INSTALLATION
 MODELS: 10263S AND 10265S

Outline and Dimensions of 10263S and 10265S Actuators

Warranty/Remedy

Honeywell warrants goods of its manufacture as being free of defective materials and faulty workmanship. Contact your local sales office for warranty information. If warranted goods are returned to Honeywell during the period of coverage, Honeywell will repair or replace without charge those items it finds defective. The foregoing is Buyer's sole remedy and is **in lieu of all other warranties, expressed or implied, including those of merchantability and fitness for a particular purpose.** Specifications may change without notice. The information we supply is believed to be accurate and reliable as of this printing. However, we assume no responsibility for its use.

While we provide application assistance personally, through our literature and the Honeywell web site, it is up to the customer to determine the suitability of the product in the application.

For more information, contact Honeywell sales at (800) 343-0228.

Distributor :

Honeywell

Sensing and Control
Honeywell
11 West Spring Street
Freeport, IL 61032