

NightStar®

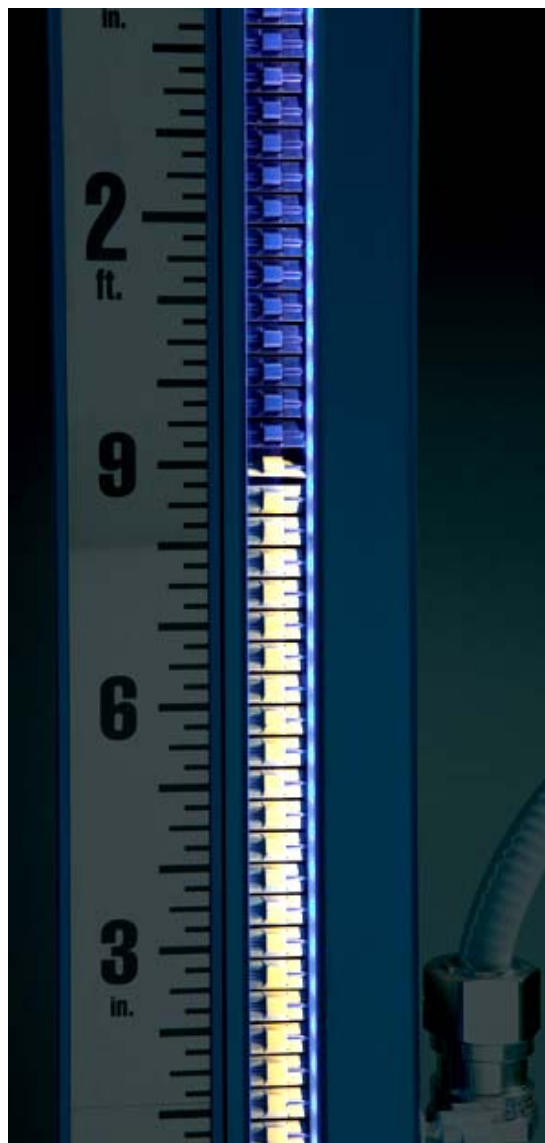

JERGUSON®

A PRODUCT OF CLARK-RELIANCE

STORAGE and HANDLING

The *NightStar*[®] Indicator meets or exceeds all applicable specifications when shipped from the factory. All units should be inspected upon receipt to ensure that no damage has been incurred during transit. If there has been damage, a claim should be filed with the carrier immediately. Unit should be stored in an area protected from the elements and corrosive fumes, in a secure manner where they can neither fall, nor be struck by other objects. Care should be taken to protect the window and the end connections from damage. Avoid placing any objects directly on the light at any time.

COMPONENTS

There are three main components that make up the *NightStar*[®]: the flag indicator/light housing, the power supply, and the cable connecting these two main pieces. The cable may have more than one piece depending on the required distance between the illuminator and the power supply. Questions regarding acceptable applications should be directed to the Clark-Reliance[®] Corporation.

ELECTRICAL CONNECTION

CAUTION: All lights are tagged with the service conditions for that particular unit. These specifications are located on the Jerguson[®] tag on the power supply housing, and are contained in the “Specifications” section of this manual. Review the ratings prior to installation and again prior to start-up. Should there be any doubt as to the applicability of a unit for the installed environment, consult the factory before placing the unit into service.

Note: All installation steps should be performed by a qualified technician and should be executed in accordance with all applicable national and local codes.

The indicator and power supply should be checked to ensure that they contain no foreign matter, and that the end connections are clean, undamaged, and in line with existing conduit.

Step by step instructions (if the indicator is received installed on a Magnetic Level Gage, proceed to step 3):

- 1) Loosen the hose clamps provided and place one around the top and bottom of the magnetic gage chamber. (See *Figure 1*).
- 2) Place the indicator on the magnetic level gage, aligning “zero” with the lower process connection. Using the hose clamps provided, fasten the clamps around the mounting ears at the top and bottom of the *NightStar*[®] indicator.
- 3) The power supply is provided mounted to the indicator. The power supply may be remote mounted up to 72ft. away. (See spare parts pg.3.)
- 4) Open the cover of the power supply housing. Insert the AC Line wires into the housing and connect to the “AC IN” terminal block. A ground screw is located inside the enclosure if required. **CAUTION:** The DC output is pre-wired. If this connection is removed during installation, reconnect the “AC IN” and “DC OUT” to the proper positions. Failure to do so will result in permanent damage to the power supply. (Ref. Figure 2 on next page)

IMPORTANT: A sealing fitting must be installed within 18” of the enclosure conduit entry.

- 5) Replace the cover on the power supply housing.

CAUTION: Verify that the area is free of flammables.

- 6) Switch “ON” the power supply making sure the Illuminator is functioning properly, with all LED’s illuminated.
- 7) Refer to the Troubleshooting section (pg.4) if a portion or all LEDs do not illuminate.

OPERATION

The LED illuminator can run continuously. The estimate operating life of the LED’s exceed 100,000 hours under normal conditions.



ROUTINE MAINTENANCE

Keep window on the front of the light clean using commercial glass cleaners, such as Windex® or similar. Never use harsh abrasives, wire brushes, metal scrapers, or any material that could scratch the window. The window may be cleaned while the unit is in operation.

Mounting NightStar®

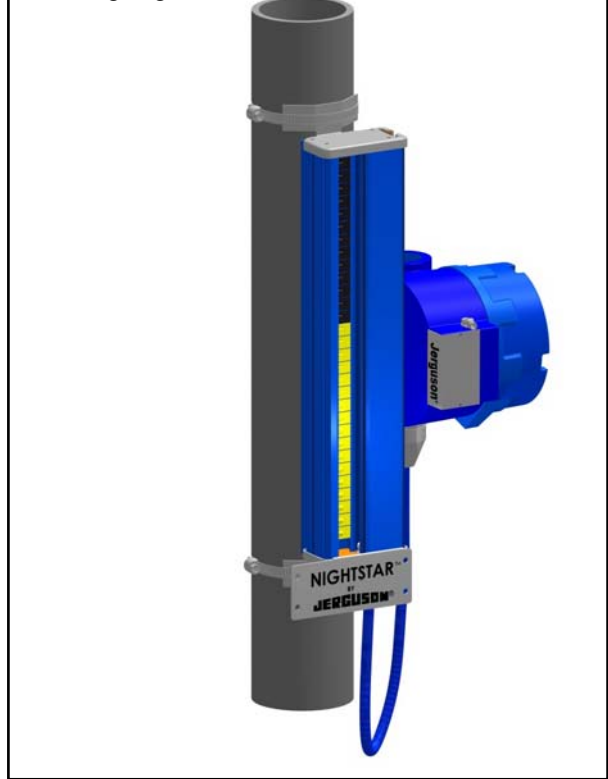

Figure 1

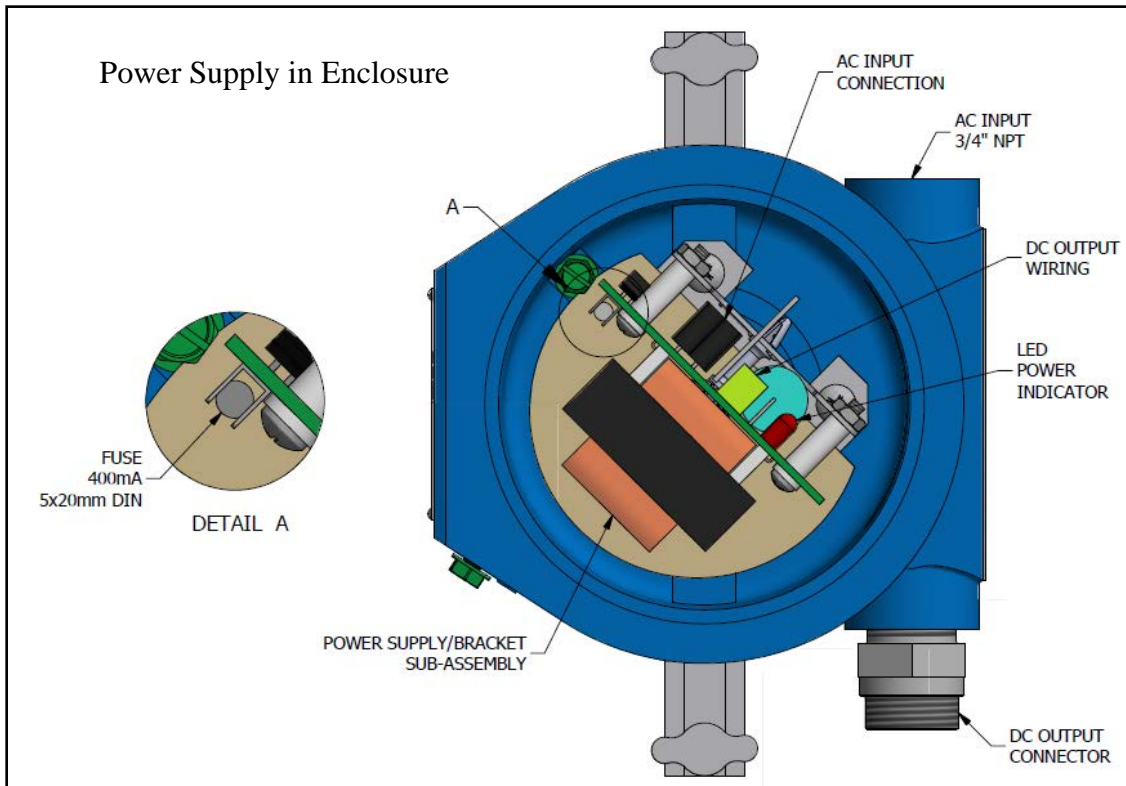

Figure 2

JERGUSON®

A PRODUCT OF CLARK-RELIANCE

16633 Foltz Parkway • Strongsville, OH 44149 USA Telephone: +1 (440) 572-1500 • Fax: +1 (440) 238-8828
www.clark-reliance.com • sales@clark-reliance.com

SPECIFICATIONS

Power Supply:	120 or 240 VAC @ 50-60 Hz
Power Consumption:	< 750 mA @ 120 VAC < 375 mA @ 240 VAC
Est. Life:	100,000 Hours (continuous)
Approvals:	FM Class I, Div. 1 Groups B, C, D T4 CSA Class I, Div. 1 Groups B, C, D T4 Associated Equipment [Exia]
Ambient Temp:	-40 F (-40 C) to 170 F (77 C)
Wire Size:	Min 18 AWG / Max 12 AWG
Max dist. power supply to light:	72 feet (22M)
Electrical Connection:	¾" FNPT

NightStar® SPARE PARTS	
Description	Part Number
120 VAC FM / CSA Power Supply Board / Bracket Sub-Assembly	S23293
230 VAC FM / CSA Power Supply Board / Bracket Sub-Assembly	S23294
120 VAC FM / CSA Power Supply w/ Explosion-Proof Enclosure	S23428
230 VAC FM / CSA Power Supply w/ Explosion-Proof Enclosure	S23429
Fuse (400 mA, Ceramic Cartridge, ATEX Certified)	E-F-DIN-F400MA (4 Fuses)
18" Cable w/ 90 degree Connector (Power Supply to 1st Light Strip)	V20509
6-1/2 foot (2 meter) Extension Cable (for Remote Mounting)	V20601-6.5
M20 metric brass adaptor (3/4"MNPT x M20 female)	V19705-F



Troubleshooting Steps

Caution: Some of these troubleshooting steps are performed with live voltage applied. The assembly should be moved to a safe area before beginning work. A qualified and properly trained technician must perform these steps.

NOTE: See Figure 3 on this page for component locations.

- 1) Remove enclosure cover and look to see if red LED power indicator is on.
 - a) If red LED is on, skip to step 4.
- 2) Check AC wiring to make sure it is properly installed and tightened in connector.
- 3) Using a meter, verify AC line voltage at AC connector.
- 4) Disconnect AC power. Using a small pair of needle-nose pliers, gently remove fuse from holder.
- 5) Check fuse for continuity with an Ohm meter. If there is continuity, re-install fuse. If there is no continuity, replace fuse.
- 6) Check DC output wiring to make sure it is properly installed and tightened.
- 7) Reconnect AC power.
- 8) Using a voltmeter set to DC; measure the voltage across the output connector. Voltage should be between 9VDC and 15VDC.
- 9) Unscrew and remove blue power cord between the power supply and NightStar[®] indicator. Inspect the 4 pins inside end connector and on the power supply to make sure they are straight and undamaged. If pins are bent, use a small pair of needle-nose pliers to straighten bent pins. If pins are broken or missing, contact factory.
- 10) Reconnect power cord making sure connectors are fully seated and tightened.
- 11) If all steps above check OK, contact factory for support.

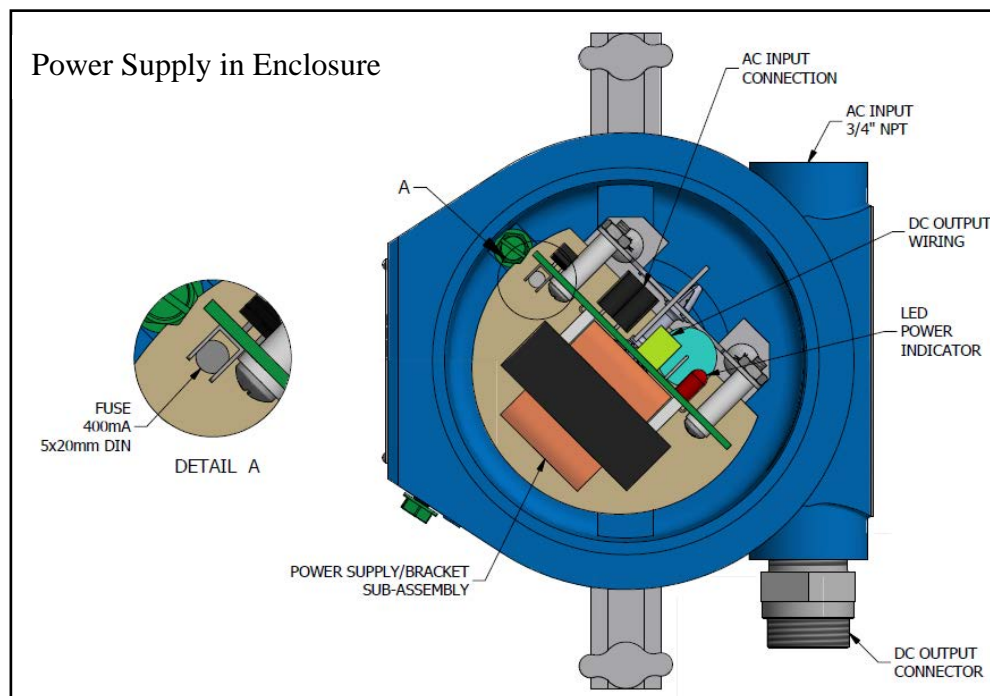

Figure 3

JERGUSON[®]
A PRODUCT OF CLARK-RELIANCE

Notes:



16633 Foltz Parkway • Strongsville, OH 44149 USA Telephone: +1 (440) 572-1500 • Fax: +1 (440) 238-8828
www.clark-reliance.com • sales@clark-reliance.com



On-Line Parts – DIRECT – for Clark-Reliance Products

JERGUSON® **Reliance®**

JACOBY-TARBOX® **MAGNE-SONICS®**



www.clark-reliance.com/parts

JERGUSON®

A PRODUCT OF CLARK-RELIANCE

16633 Foltz Parkway • Strongsville, OH 44149 USA Telephone: +1 (440) 572-1500 • Fax: +1 (440) 238-8828
www.clark-reliance.com • sales@clark-reliance.com